

Reparaturanleitung  
Repair Manual  
Manuel de Réparation  
Manual de Reparaciones  
Manuale di Riparazione

# 8 HP 55 A

Car Automatic-Transmission





subject to alterations.

© Copyright 2014, all rights reserved and published by  
ZF Friedrichshafen AG, ZF Services, Saarbrücken, Department MAPS14

No part of this document may be copied or transferred for any purpose without the  
express consent of ZF Friedrichshafen AG, Saarbrücken regardless of how this is  
done or by what means, either mechanical or electrical.

Printed in Germany.

# Contents

	<b>Preliminary information</b>	<b>IV</b>
<b>1.</b>	<b>General</b>	<b>1.1/1</b>
1.1	Illustration of transmission	1.1/1
1.2	Power flow diagram	1.2/1
1.3.	Screw connection specifications	1.3/1
	1.3.1 Mechatronic unit types M and E	1.3/1
	1.3.2 Oil pan	1.3/1
	1.3.3 Differential cover	1.3/1
	1.3.4 Distribution housing	1.3/2
	1.3.5 Intermediate housing	1.3/2
	1.3.6 Converter housing	1.3/2
	1.3.7 Oil supply	1.3/3
	1.3.8 Intermediate plate	1.3/3
	1.3.9 Guide plate	1.3/3
1.4	Adjustment work	1.4/1
	1.4.1 Measuring multidisk package	1.4/1
	1.4.2 Clutch D air clearance adjustment	1.4/3
	1.4.3 Clutch C air clearance adjustment	1.4/7
	1.4.4 Clutch E air clearance adjustment	1.4/11
	1.4.5 Brake A air clearance adjustment	1.4/15
	1.4.6 Brake B air clearance adjustment	1.4/19
	1.4.7 Switch adjustment (locking spring)	1.4/23
	1.4.8 Bevel gear (front axle differential)	1.4/25
	1.4.8.1 Pinion position	1.4/25
	1.4.8.2 Pinion shaft bearing design height	1.4/26
	1.4.8.3 Regulations for the adjusting washer for the pinion shaft bearing	1.4/28
	1.4.8.4 Crown gear position torsional clearance	1.4/29
	1.4.8.5 Differential prestressing	1.4/30
	1.4.9 Transmission clearance and front axle output	1.4/32
1.5	Tightening torques	1.5/1
1.6	Transmission test	1.6/1
1.7	Special tools	1.7/1
1.8	Oil flow diagram	1.8/1
	1.8.1 DIN schematic E26/4	1.8/1
	1.8.2 DIN schematic E26/6	1.8/2
	1.8.3 DIN schematic E26/15	1.8/3
	1.8.4 DIN schematic E26/17	1.8/4

<b>2.</b>	<b>Dismantling</b>	<b>2.1/1</b>
2.1	Preparations	2.1/1
	2.1.1 Drain transmission oil	2.1/1
2.2	Transmission clearance and front axle output	2.2/1
	2.2.1 Remove and dismantle distribution housing	2.2/1
	2.2.2 Remove intermediate housing and dismantle front axle output	2.2/3
	2.2.3 Dismantle front axle shaft	2.2/7
	2.2.4 Dismantle output gear	2.2/9
	2.2.5 Dismantle drive wheel	2.2/10
	2.2.6 Dismantle side shaft	2.2/11
2.3	Remove flanged shaft, front axle differential and converter	2.3/1
	2.3.1 Remove flanged shaft and front axle differential	2.3/1
	2.3.2 Dismantle flanged shaft	2.3/3
	2.3.3 Remove converter	2.3/4
	2.3.4 Remove converter housing	2.3/5
	2.3.5 Dismantle converter housing	2.3/6
	2.3.6 Remove pinion shaft	2.3/8
	2.3.7 Dismantle pinion shaft	2.3/9
2.4	Remove oil pan, mechatronic unit and parking lock	2.4/1
	2.4.1 Remove oil pan and oil filter	2.4/1
	2.4.2 Remove mechatronic unit	2.4/1
	2.4.3 Remove parking lock	2.4/6
2.5	Remove and dismantle oil supply	2.5/1
	2.5.1 Remove oil supply	2.5/1
	2.5.2 Dismantle oil supply	2.5/1
2.6	Remove and dismantle tower	2.6/1
2.7	Remove clutches	2.7/1
	2.7.1 Remove clutch E	2.7/1
	2.7.2 Remove clutch C	2.7/1
	2.7.3 Remove clutch D	2.7/2

<b>3.</b>	<b>Assembly</b>	<b>3.1/1</b>
3.1	Preparations	3.1/1
	3.1.1 Install parking lock and gearshift	3.1/3
3.2	Kupplungen montieren	3.2/1
	3.2.1 Clutch D	3.2/1
	3.2.2 Clutch C	3.2/4
	3.2.3 Clutch E	3.2/6
3.3	Assemble tower and oil supply	3.3/1
	3.3.1 Assemble tower	3.3/2
	3.3.2 Assemble oil supply	3.3/9
	3.3.3 Assemble brake A	3.3/12
	3.3.4 Assemble brake B	3.3/14
3.4	Install tower and oil supply in transmission	3.4/1
	3.4.1 Install tower	3.4/1
	3.4.2 Install oil supply	3.4/3
3.5	Assemble mechatronic unit and oil pan	3.5/1
	3.5.1 Install mechatronic unit	3.5/1
	3.5.2 Install oil pan	3.5/5
3.6	Complete and install converter housing	3.6/1
	3.6.1 Complete differential cover	3.6/1
	3.6.2 Complete and install pinion shaft	3.6/2
	3.6.3 Complete converter housing	3.6/3
	3.6.4 Install differential in converter housing	3.6/5
	3.6.5 Pre-assemble flanged shaft	3.6/7
	3.6.6 Install converter housing on transmission housing	3.6/8
	3.6.7 Install converter and flanged shaft	3.6/9
3.7	Assemble front axle output	3.7/1
	3.7.1 Complete intermediate housing	3.7/1
	3.7.2 Prepare transmission housing, assemble side shaft	3.7/2
	3.7.3 Complete drive wheel	3.7/4
	3.7.4 Complete output gear	3.7/6
	3.7.5 Complete front axle shaft	3.7/6
	3.7.6 Assemble drive wheel, front axle shaft and output gear	3.7/7
3.8	Assemble rear axle output	3.8/1
	3.8.1 Prepare and assemble distribution housing	3.8/1
	3.8.2 Complete and assemble the rear axle output	3.8/3
	Revisions	XI

# Preliminary information

This manual contains the procedure for repairing the complete transmission.

The repair manual is only readily comprehensible if it is backed by ZF-Services training. Failure to follow the manual may result in incorrect installations.

All dismantling and assembly work must be carried out in chronological order.

The photographs have been kept general for the various applications and are not binding in all cases.

Major modifications for specific applications which must be taken into consideration in the repair work are published in *Technical Bulletins* and training courses.

The specifications and information from SDM and Serviceline must be used for the repair work. See also the maintenance recommendations for the list of lubricants for automatic transmissions.

Please note the following:

- Seals such as O-rings, shaft sealing rings and filters must generally be replaced.
- A thin coating of Vaseline must be applied to all O-rings, rectangular rings and other sealing rings or with a film of transmission oil before installation. Metal seals must be fitted dry and without any grease.
- All bearings must be installed with a light coating of oil.
- Lining and steel disks may be replaced or reused depending on their condition.
- After clutches/brake have been damaged the converter, oil pipes and oil cooler must be thoroughly and adequately cleaned with a suitable cleaning product.
- Aluminum screws must always be replaced.

The following conditions should be satisfied before starting the repair work:

- The required special tools must be available (see section 1.7), otherwise incorrect assembly is possible.
- A suitable transmission test bed must be available.  
The required test values are set out in the *Technical Bulletins*.

The mechatronic unit is described in this manual as a complete unit and should not be dismantled by personnel without special skills but should be replaced in full.

A separate manual is planned for the mechatronic unit.

### **Important**

The transmission is filled with oil for its full service life.

**The oil only has to be replaced after the vehicle has covered between 80,000 km and 120,000 km, depending on the drive conditions, or after 8 years. (see ref. TE-ML 11)**

The transmission may only be delivered with the oil volume and type set out in the relevant parts lists document (see SDM).

Technical After-Sales

Technical Documentation

After-Sales Workshop

**Herth**

**Reus**

**Stubauer**





1. General  
1.1 Illustration of transmission





## 1.2 Power flow diagram

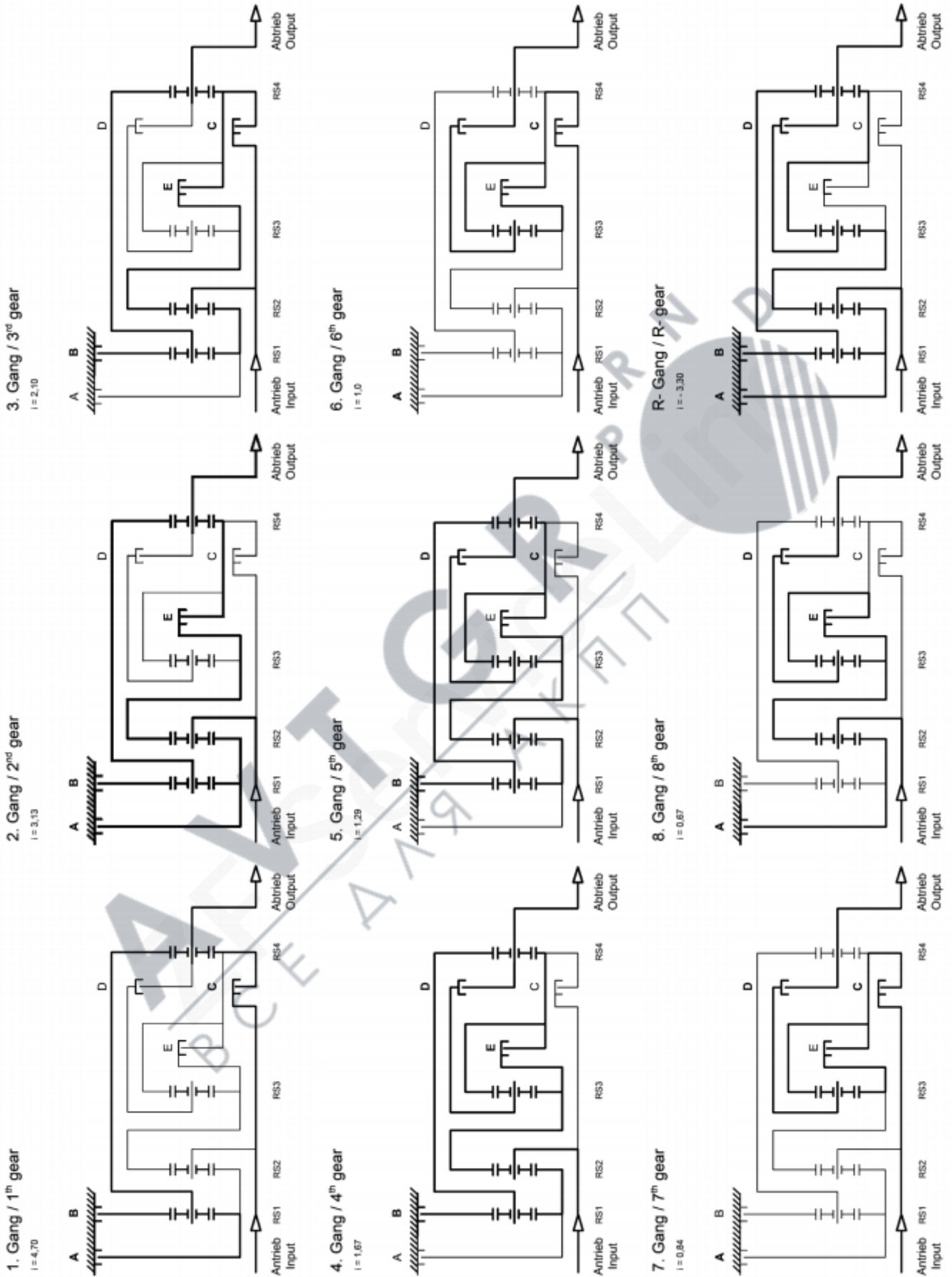

# Transmission ratio

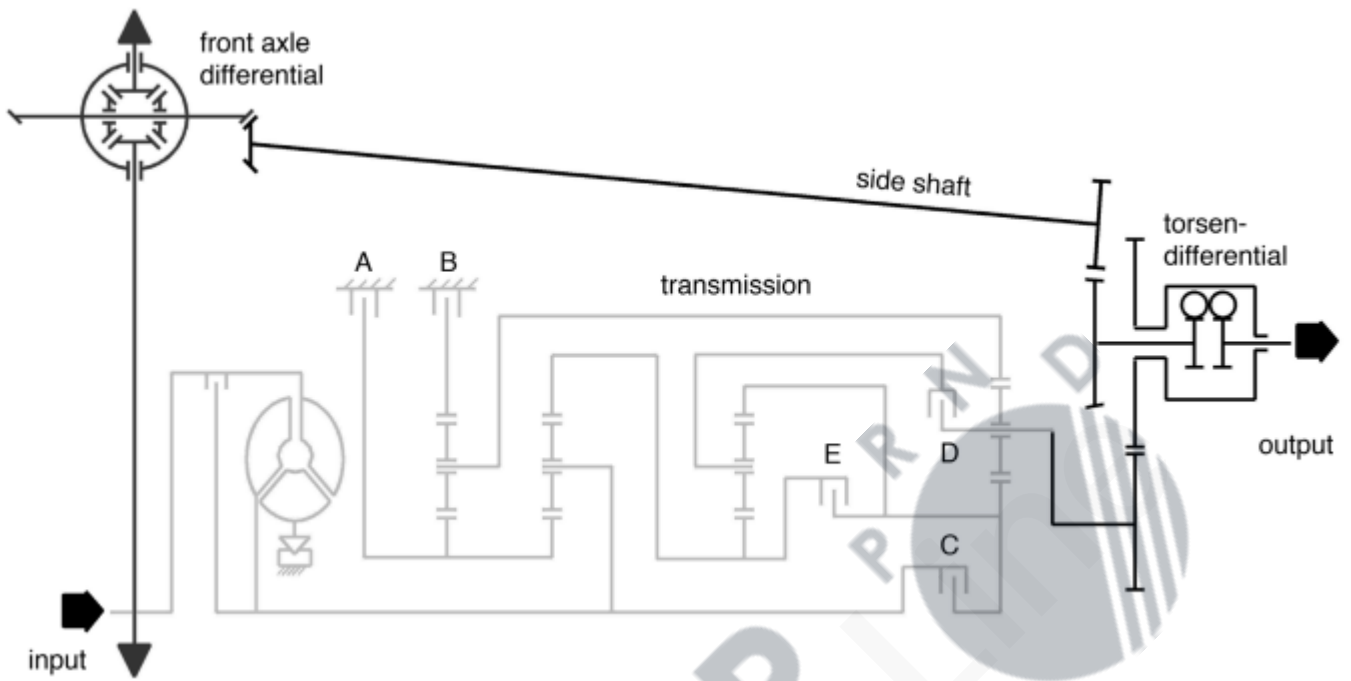

### 1.3. Screw connection specifications

#### 1.3.1 Mechatronic unit types M and E

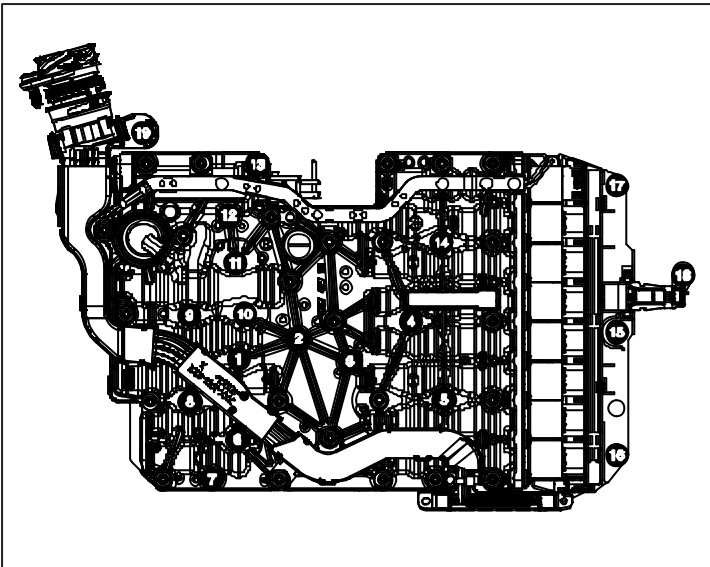

##### **NOTICE**

Use the assembly sequence set out in specification 1087.700.079.

See section 1.5 for tightening torques.

Tighten 19 screws on mechatronic unit in following order:

1 ⇔ 2 ⇔ 3 ⇔ ... ⇔ 19

#### 1.3.2 Oil pan

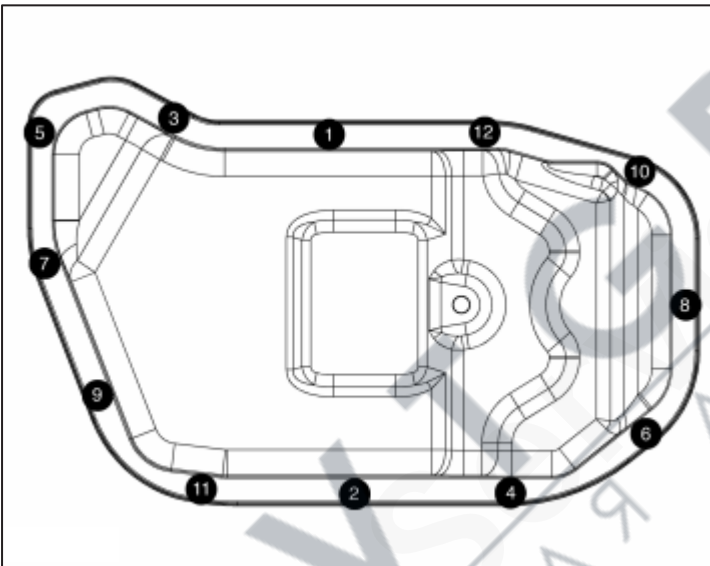

##### **NOTICE**

Use the assembly sequence set out in specification 1087.700.272.

See section 1.5 for tightening torques.

Tighten 12 screws on oil pan in following order:

1 ⇔ 2 ⇔ 3 ⇔ ... ⇔ 12

#### 1.3.3 Differential cover

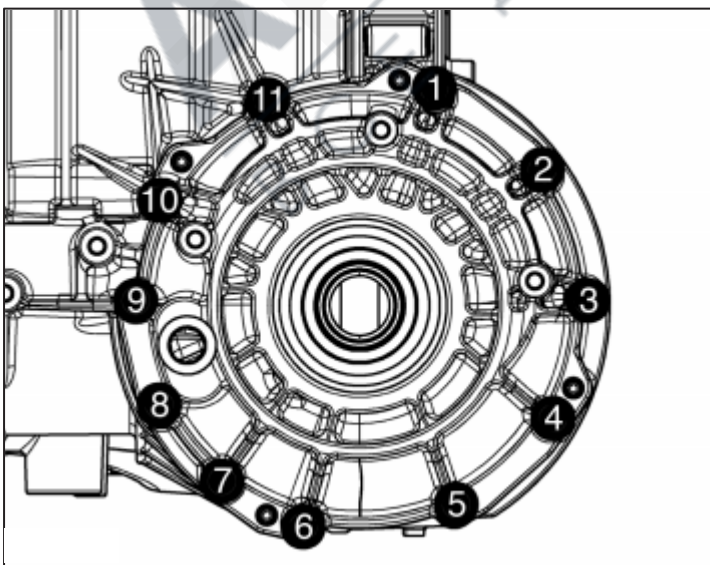

##### **NOTICE**

Use the assembly sequence set out in specification 1084.700.007.

Tighten 11 screws on intermediate housing in 2 stages:

Sequence	Screw	Tightening torque
1	10, 5	$4,0 \pm 1,0$ Nm
2	1 - 11	$27,0 \pm 2,7$ Nm

Special feature: Screw 10 with coating

### 1.3.4 Distribution housing

#### NOTICE

Use the assembly sequence set out in specification 1084.700.011.

See section 1.5 for tightening torques.

Tighten 6 screws on distribution housing in following order:

1 ⇄ 2 ⇄ 3 ⇄ ... ⇄ 6

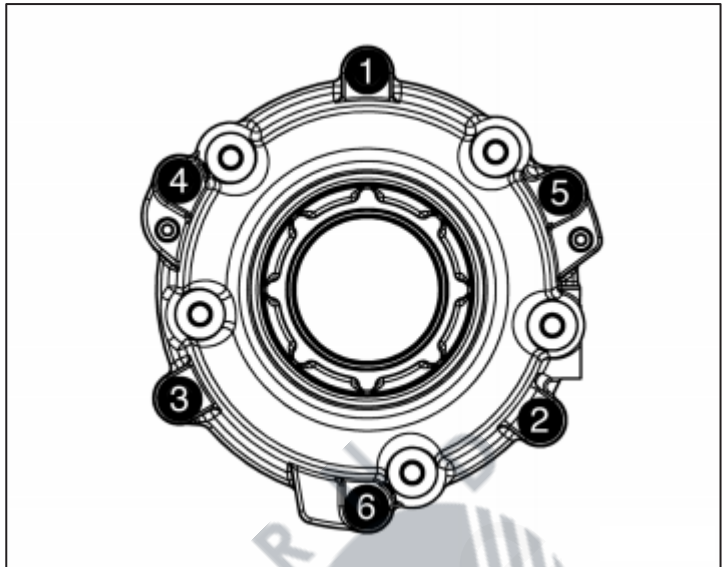

### 1.3.5 Intermediate housing

#### NOTICE

Use the assembly sequence set out in specification 1084.700.012.

Tighten 15 screws on intermediate housing in 3 stages:

Sequence	Screw	Tightening torque
1	6, 10	$6,0 \pm 1,0 \text{ Nm}$
2	1 - 11	$10,0 \text{ Nm} + 90^\circ \pm (1,0 \text{ Nm} + 5^\circ)$
3	12 - 15	$47,0 \pm 4,7 \text{ Nm}$

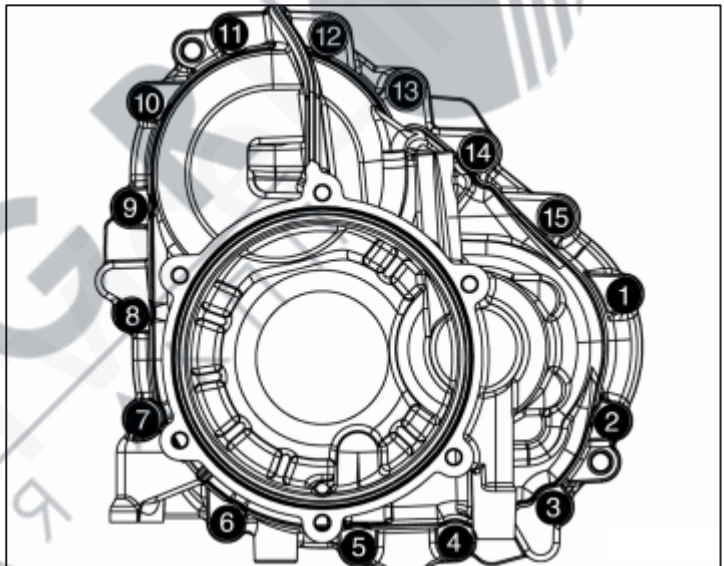

### 1.3.6 Converter housing

#### NOTICE

Use the assembly sequence set out in specification 1087.700.081.

Tighten 15 screws on converter housing in 3 stages:

Sequence	Screw	Tightening torque
1	1, 2	$9,0 \pm 1,0 \text{ Nm}$
2	1 - 14	$9,0 \text{ Nm} + 60^\circ \pm (1,0 \text{ Nm} + 5^\circ)$
3	15	$16,0 \text{ Nm}$

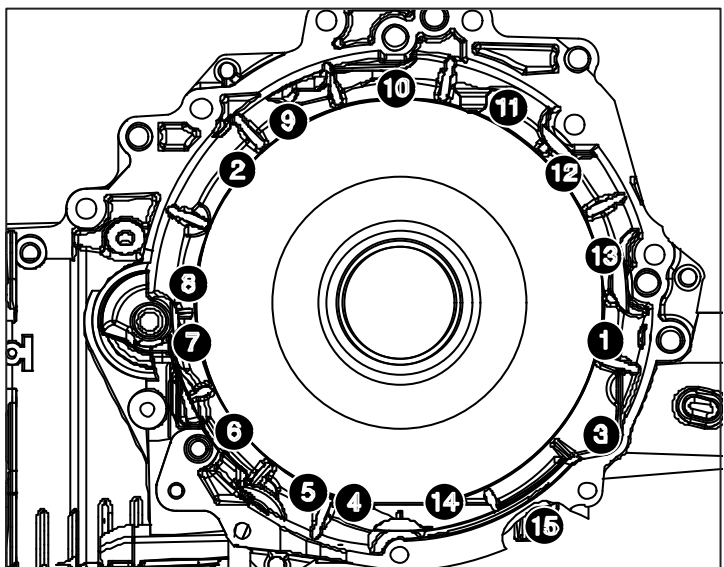

### 1.3.7 Oil supply

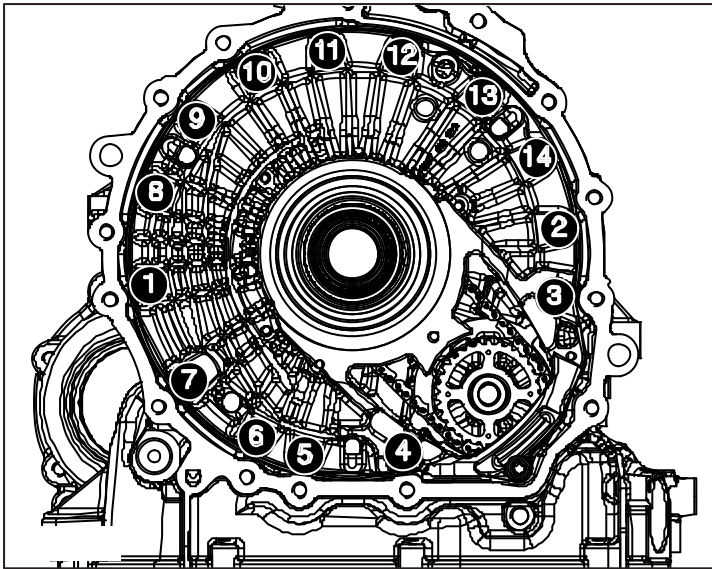

#### NOTICE

Use the assembly sequence set out in specification 1084.700.163.

See section 1.5 for tightening torques.

Tighten 14 screws on distribution housing in following order:

1 ⇔ 2 ⇔ 3 ⇔ ... ⇔ 14

### 1.3.8 Intermediate plate

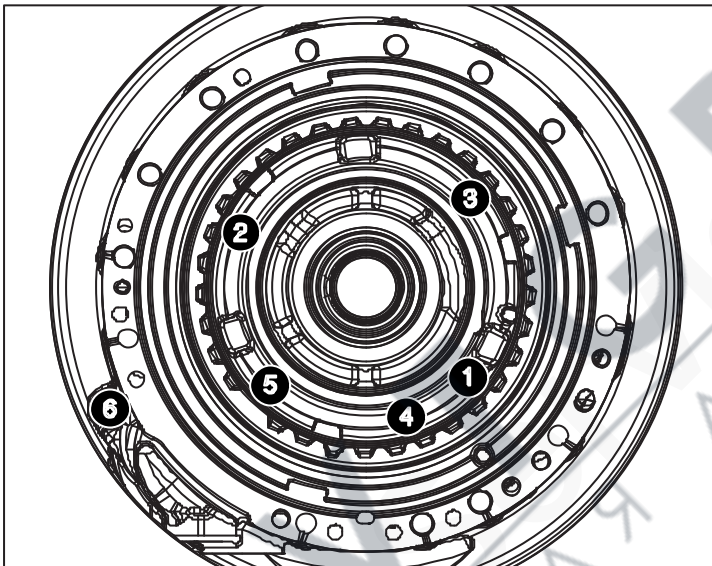

#### NOTICE

Use the assembly sequence set out in specification 1090.700.133.

See section 1.5 for tightening torques.

Tighten screws on oil supply in the following order:

1 ⇔ 2 ⇔ 3 ⇔ ... ⇔ 5

### 1.3.9 Guide plate

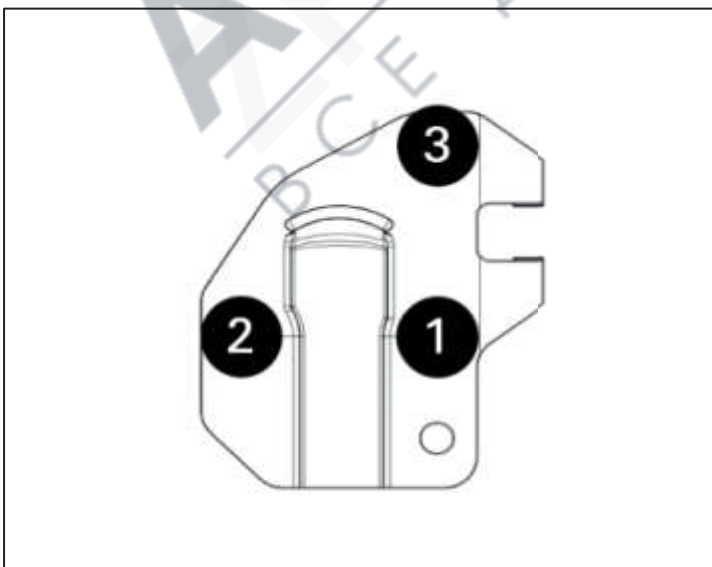

#### NOTICE

Use the assembly sequence set out in specification 1087.700.205.

See section 1.5 for tightening torques.

Tighten guiding plate screws according to tables:

Sequence	Screw	Tightening torque
1	3	Turn in, 2-4 turns
2	1 - 3	10,0 Nm (± 1,0 Nm)





## 1.4 Adjustment work

### 1.4.1 Measuring multidisk package

Place the 2 spacers 5p01.000.329 on marked points on measuring device 5p01.000.330.



Use the knurled screw to turn adjusting fixture 5p01.001.458 to the upper limit position.

Attach strain gauge 5p01.000.329 in the adjusting fixture.



Tighten the 4 knurled screws 5p01.000.329 to secure the adjusting fixture firmly with the height measuring fixtures by way of the spacers.

Connect measuring plate 5p01.040.330 to the strain gauge with the locating pin.

Clamp the disk cluster to be measured into the fixture, using the knurled screw (the corrugated steel disk, if present, must be at the bottom).



Check value on display of force measuring unit.

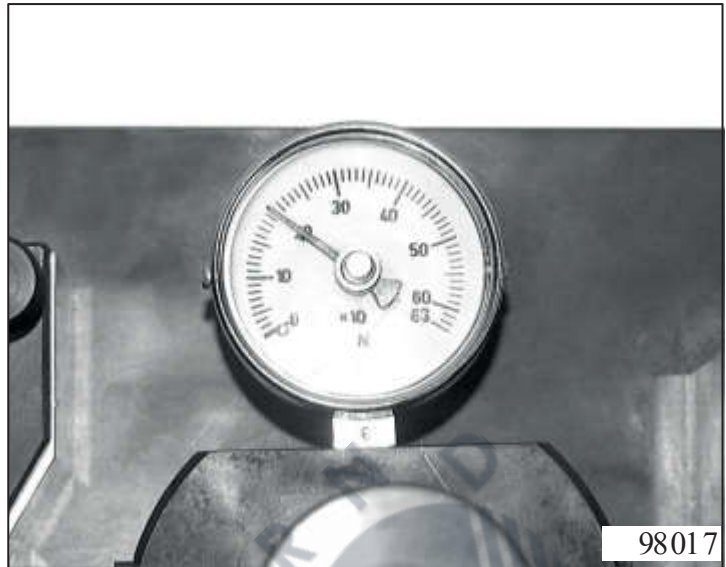

Place measuring beam 5p01.000.330 on measuring plate.

Place measuring foot of dial gage in groove in measuring plate on topmost disk in multidisk package.

Set dial to zero.

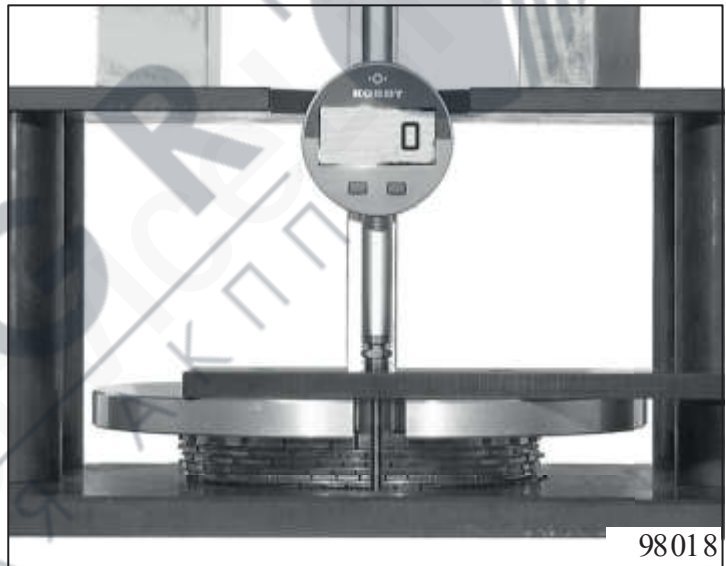

Move measuring beam down to base plate.

Read measurement ⇔  $M_{X^*}$

\*Index X stands for inserted multidisk package from clutches/brakes. (A, B, C, D, E)

#### 1.4.2 Clutch D air clearance adjustment

(Adjustment specification 1087.700.135)

Multidisk package consists of following:  
a coil spring followed by, alternately:  
external disk > lining disk and finally an  
end disk.

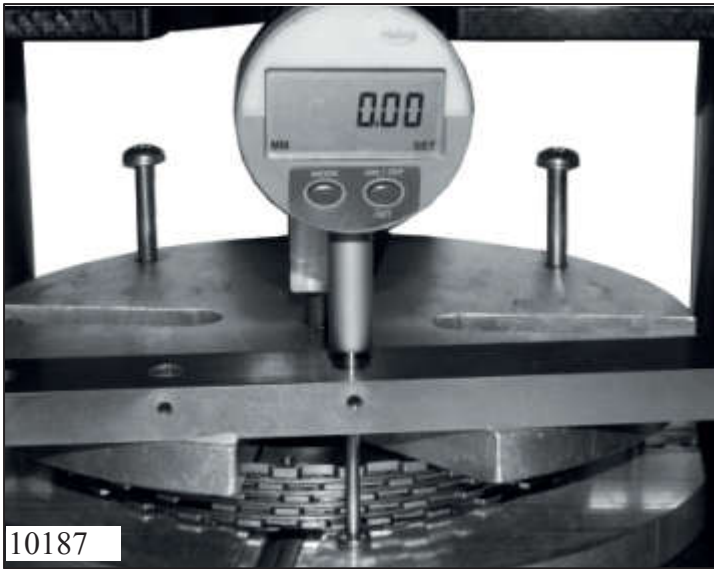

Place multidisk package into measuring unit, prestressing force = 200 N.

Place measuring beam with dial gage on pressure plate of measuring unit.

Position on measuring sensor on base plate and set dial gage to "0".

Carry out measurement on multidisk package.

Read measurement

$$\Leftrightarrow M_{DLP} = 20.46 \text{ mm}$$

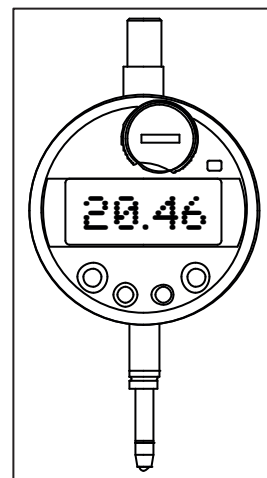
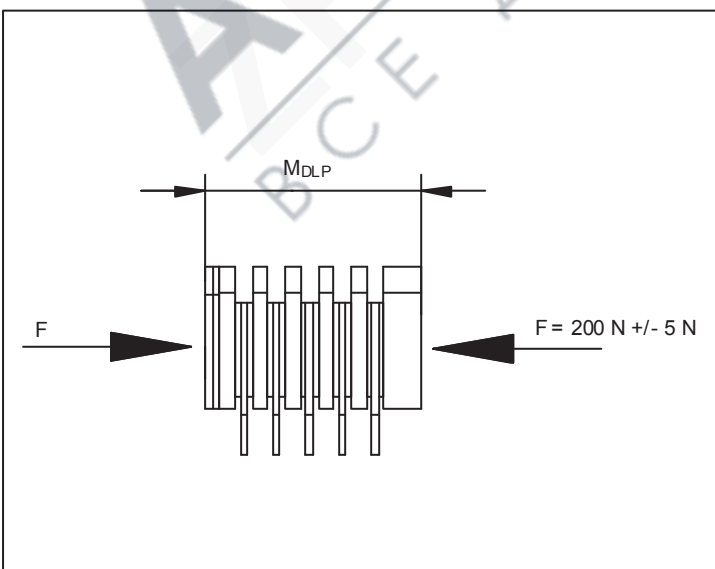
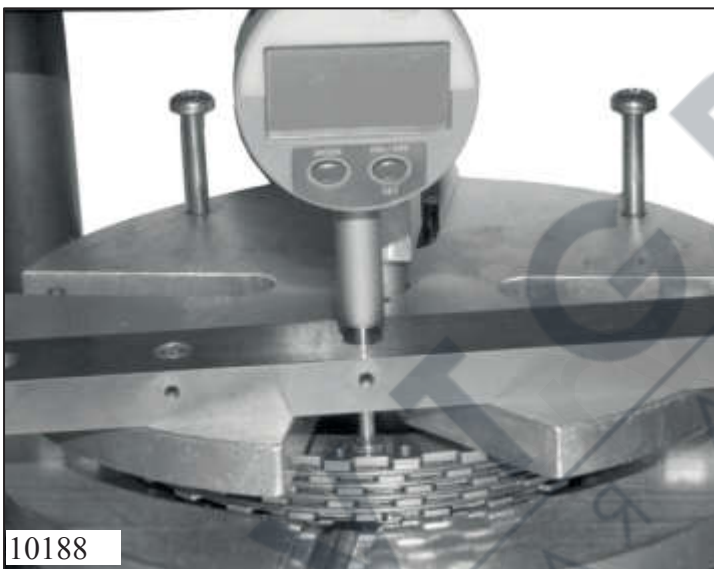

Place measuring beam with dial gage on cylinder D.

Place measuring sensor on piston D.

Set dial gage to "0" and find dimension to top of the snap ring groove.

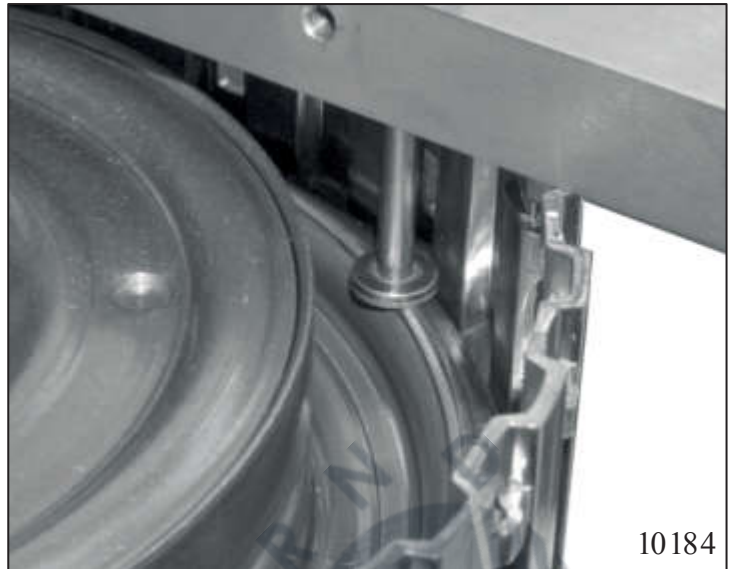

10184

Repeat measurement at 3 places and find measurements.

$M_1 = 21.97 \text{ mm}$ ,  
 $M_2 = 21.96 \text{ mm}$ ;  
 $M_3 = 21.96 \text{ mm}$

Average value

$\Leftrightarrow M_{DSR} = 21.96 \text{ mm}$

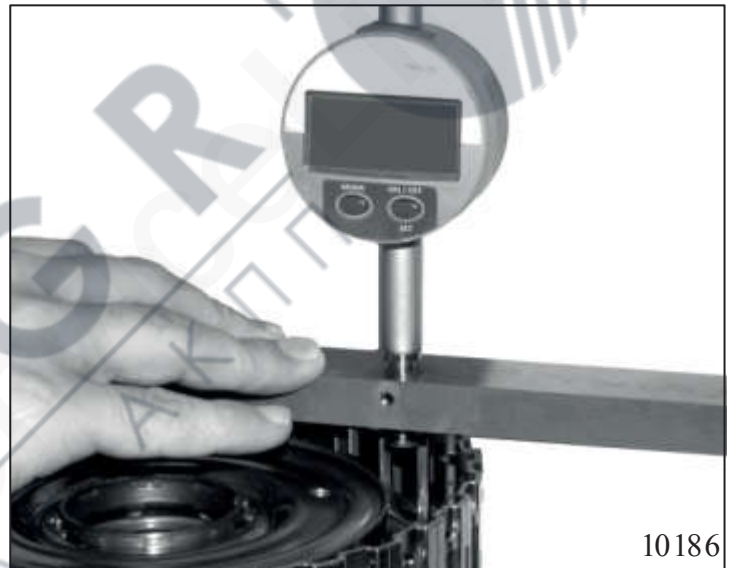
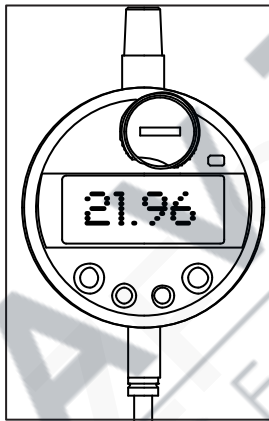

10186

Thickness of measuring sensor  
 $M_{MT} = 1.80 \text{ mm}$

$M_{DZYL} = M_{DSR} + M_{MT}$   
 $M_{DZYL} = 21.96 + 1.80 \text{ [mm]}$   
 $M_{DZYL} = 23.76 \text{ mm}$

$M_D = M_{DZYL} - M_{DLP}$   
 $M_D = 23.76 - 20.46 \text{ [mm]}$   
 $M_D = 3.30 \text{ mm}$

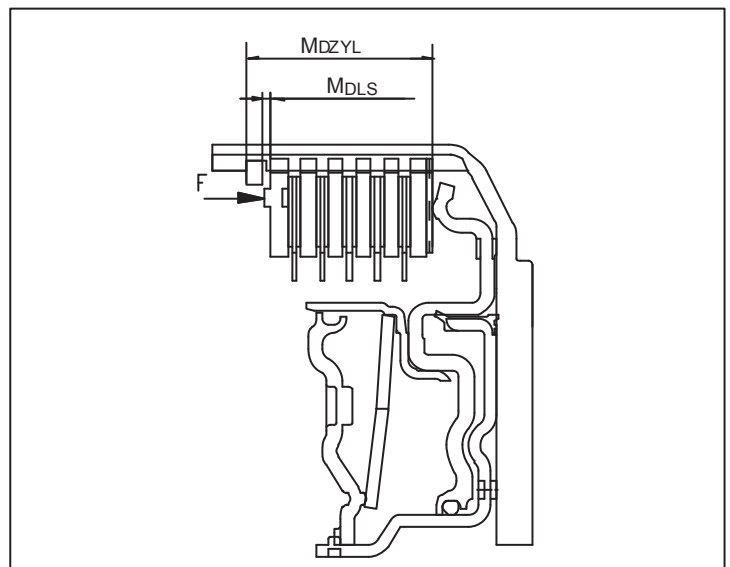

Thickness of snap ring:

$$M_{\text{DSP}} = 1.8 \text{ mm}$$

Air clearance:

$$M_{\text{DLS Act}} = M_{\text{D}} - M_{\text{DSP}}$$

$$M_{\text{DLS Act}} = 3.3 - 1.8 \text{ [mm]}$$

$$M_{\text{DLS Act}} = 1.50 \text{ mm}$$

Adjustment specification 1087.700.135  
(fitted with 4 lining disks)

$$M_{\text{DLS Des}} = 1.33 \text{ to } 1.62 \text{ mm}$$

⇔ Snap ring thickness  $M_{\text{DSP}}$  with 1.8 mm  
= OK.





### 1.4.3 Clutch C air clearance adjustment

(Adjustment specification 1087.700.044)

Multidisk package consists of following:  
a coil spring followed by, alternately:  
external disk > lining disk and finally an  
end disk.

$$\Leftrightarrow M_{CEL}: 3.6 \text{ mm}$$

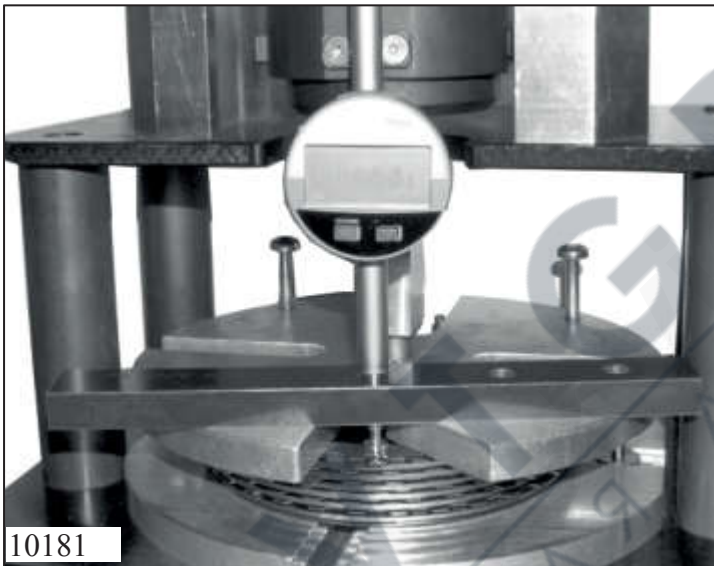
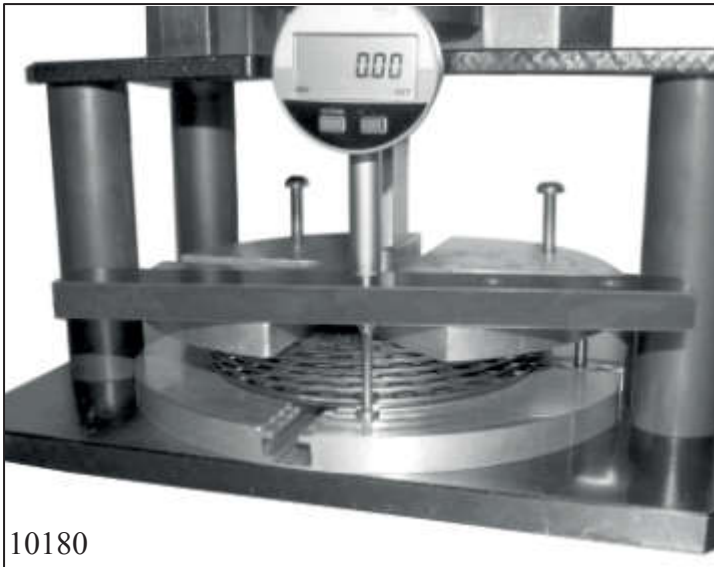

Place multidisk package (without end disk) into measuring unit, prestressing force = 200 N.

Place measuring beam with dial gage on pressure plate of measuring unit.

Position on measuring sensor on base plate and set dial gage to "0".

Carry out measurement on multidisk package.

Read measurement

$$\Leftrightarrow M_{CLP} = 26.,31 \text{ mm}$$

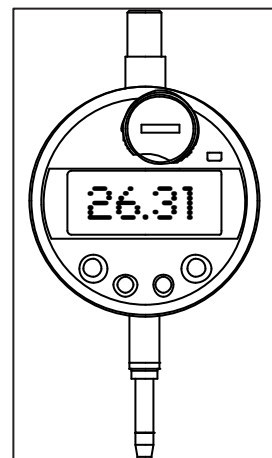
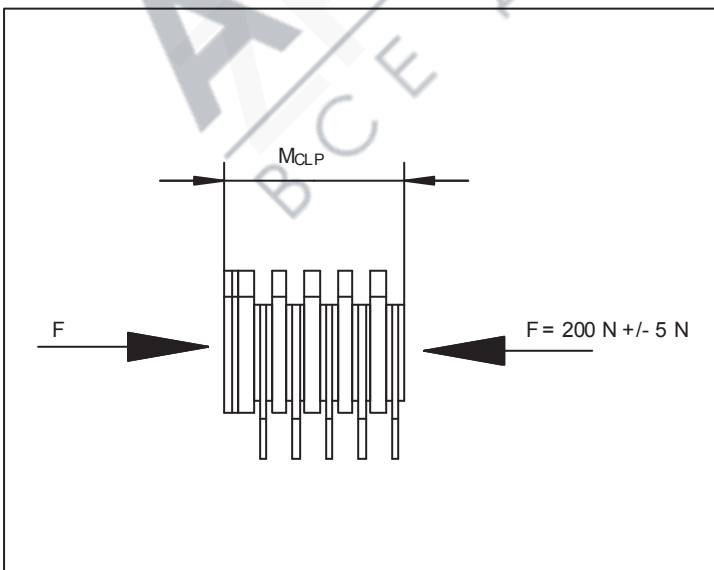

Assemble cylinder C with end disk and secure it with old snap ring.

Use height gage to find dimension from top of the end disk to support of the disk tooting.



10182

Read the measurement ⇔  
 $M_{CZYL} = 28.507 \text{ mm}$

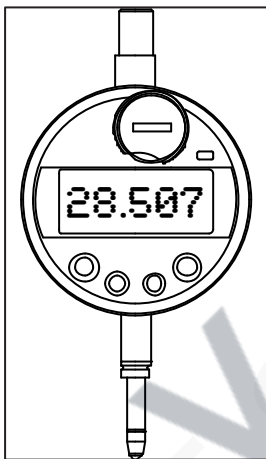

10183

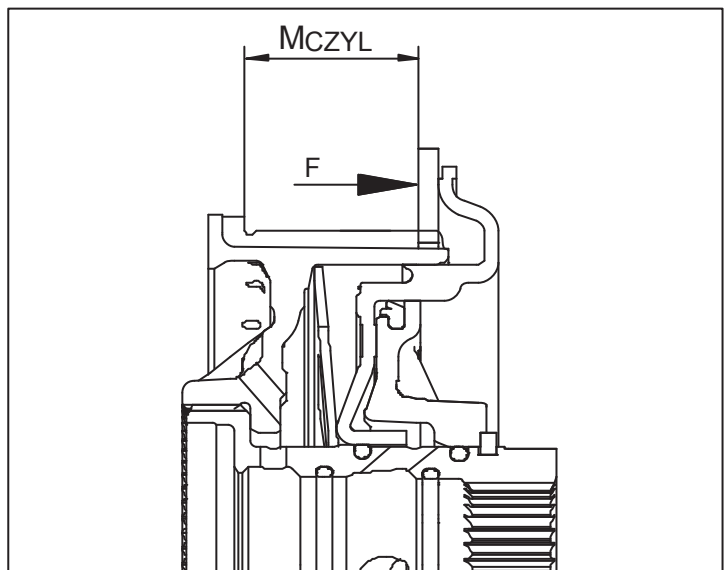



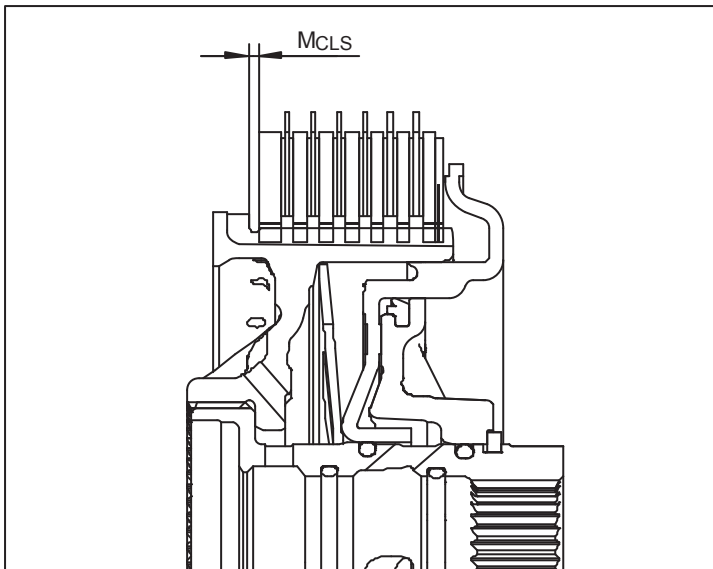

Air clearance:

$$M_{CLS \text{ Act}} = M_{CZYL} - M_{CLP}$$

$$M_{CLS \text{ Act}} = 28.507 - 26.31 \text{ mm}$$

$$M_{CLS \text{ Act}} = 2.197 \text{ mm}$$

Adjustment specification 1087.700.044  
(fitted with 6 lining disks)

$$M_{CLS \text{ Des}} = 1.90 \text{ to } 2.40 \text{ mm}$$

⇒ End disk  $M_{CEL}$  with 3.6 mm = OK.





#### 1.4.4 Clutch E air clearance adjustment

(Adjustment specification 1087.700.093)

Multidisk package consists of following: a coil spring followed by, alternately: external disk > lining disk and finally an end disk 3.3 mm).

$$\Leftrightarrow M_{EEL}: 3.3 \text{ mm}$$

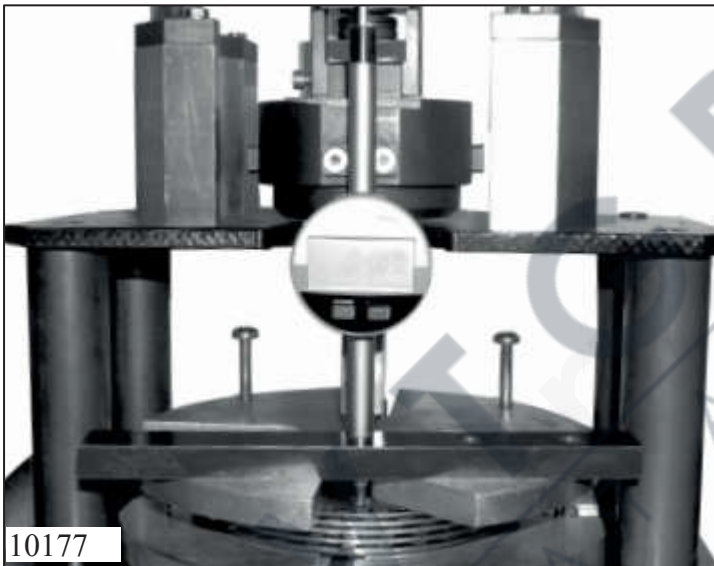
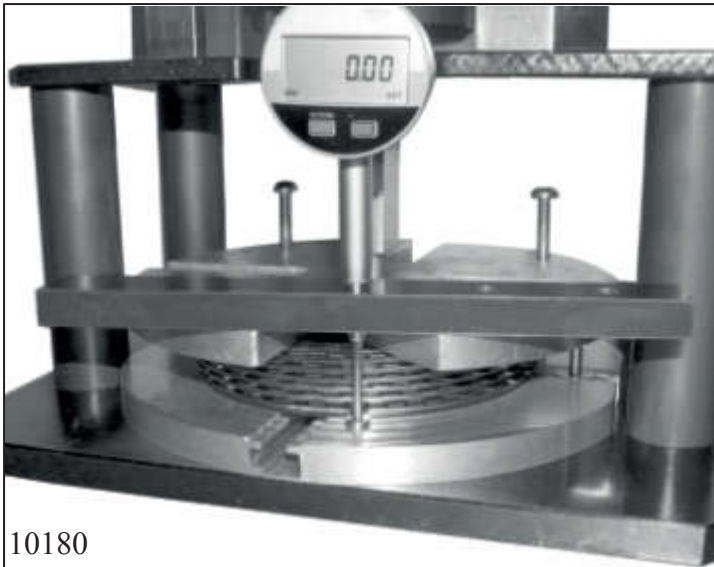

Place Multidisk package (without end disk) into measuring unit, prestressing force = 200 N.

Place measuring beam with dial gage on pressure plate of the measuring unit.

Position on measuring sensor on base plate and set dial gage to "0".

Carry out measurement on multidisk package.

Read measurement

$$\Leftrightarrow M_{ELP} = 21.67 \text{ mm}$$

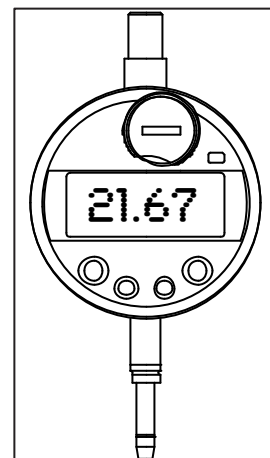
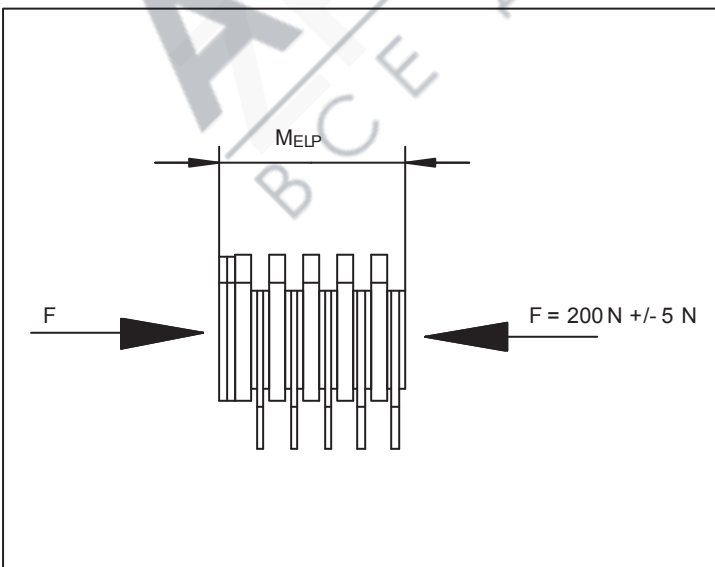

Assemble cylinder E with end disk and secure it with old round wire ring.

Use height gage to find the dimension from top of the end disk to support of the disk tooting.

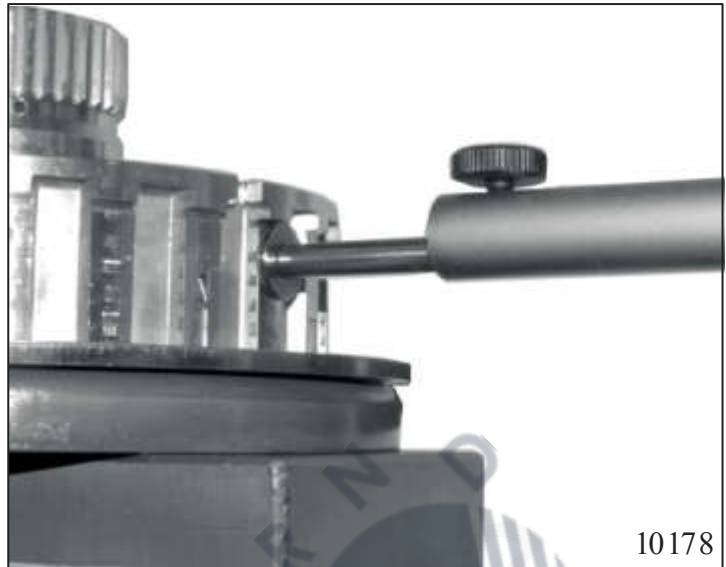

Read measurement

$\Leftrightarrow M_{EZY L} = 23.75 \text{ mm}$

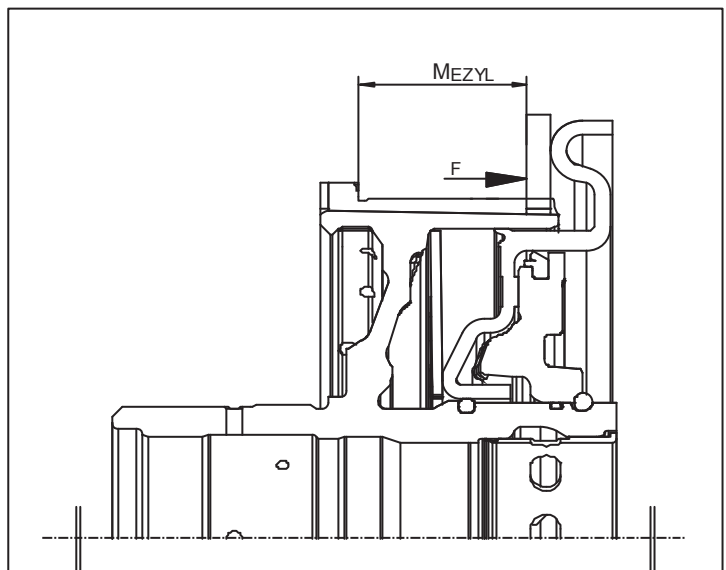
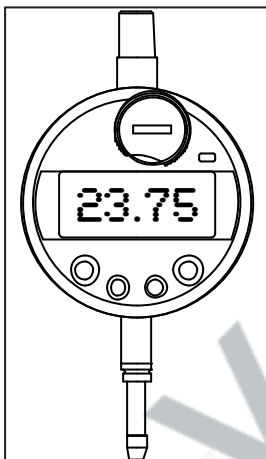

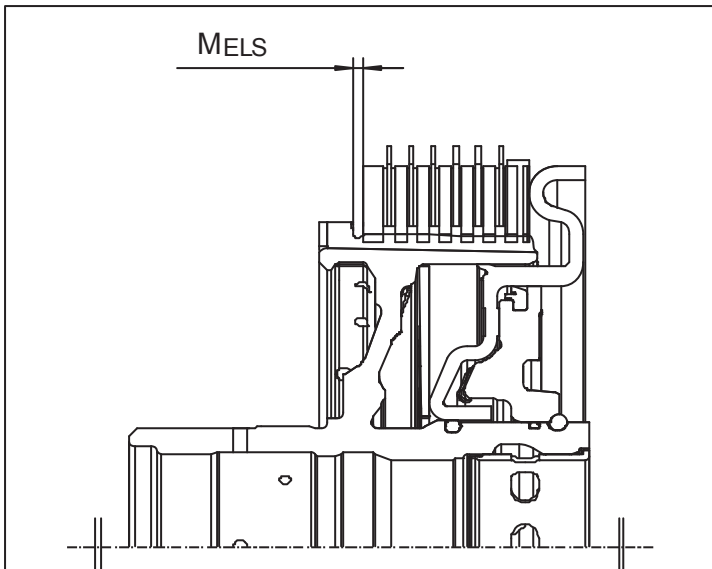

Air clearance:

$$M_{ELS Act} = M_{EZY} - M_{DSP}$$

$$M_{ELS Act} = 23.75 - 21.67 \text{ mm}$$

$$M_{ELS Act} = 2.08 \text{ mm}$$

Adjustment specification 1087.700.093  
(fitted with 5 lining disks)

$$M_{ELS Des} = 1.56 \text{ to } 2.05 \text{ mm}$$

⇔ End disk  $M_{EEL}$  with 3.3 mm  
= Inadequate.

New end disk with a thickness of 3.6 mm

Read the measurement

$$\Leftrightarrow M_{ELP} = 21.97 \text{ mm}$$

$$M_{ELS Act} = 23.75 - 21.97 \text{ mm}$$

$$M_{ELS Act} = 1.78 \text{ mm}$$

⇔ End disk  $M_{EEL}$  with 3.6 mm = OK



### 1.4.5 Brake A air clearance adjustment

(Adjustment specification 1087.700.039)

Multidisk package consists of following:  
a coil spring followed by, alternately:  
external disk > lining disk and finally an  
end disk.

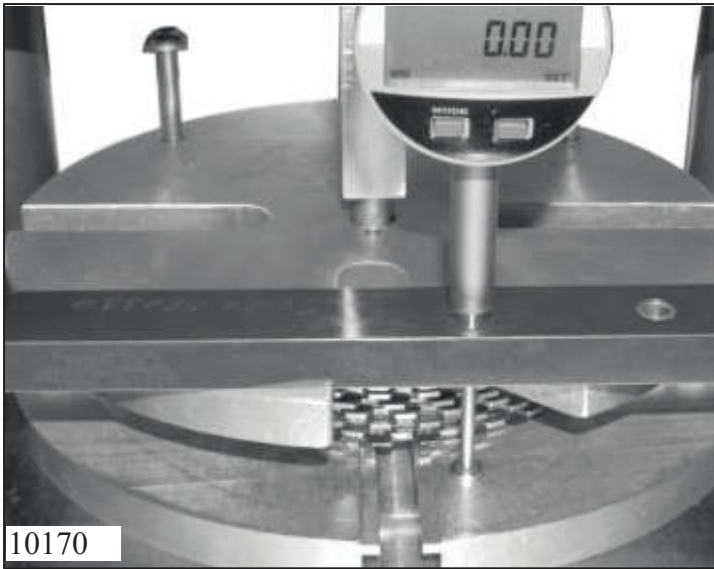

Place multidisk package into measuring unit, prestressing force = 200 N.

Place measuring beam with dial gage on pressure plate of the measuring unit.

Position on measuring sensor on base plate and set dial gage to "0".

Carry out measurement on multidisk package.

Read measurement

$$\Leftrightarrow M_{ALP} = 20.78 \text{ mm}$$

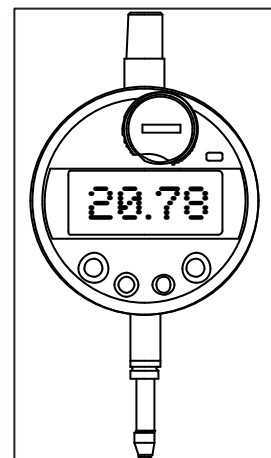
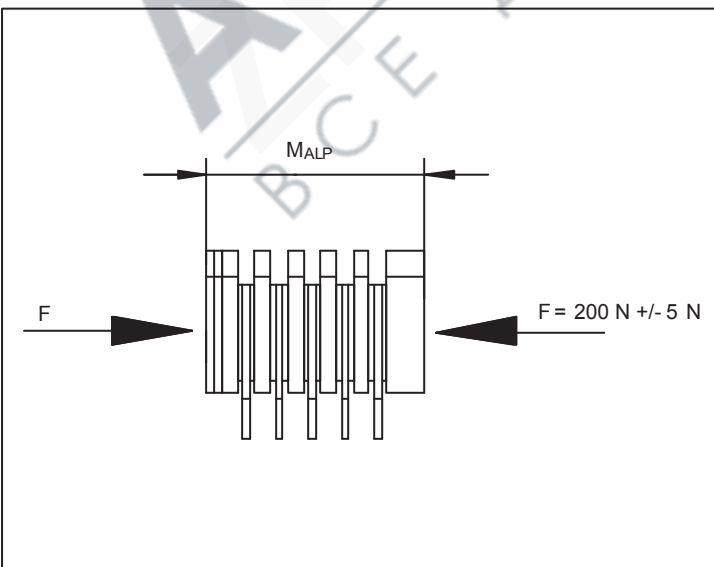
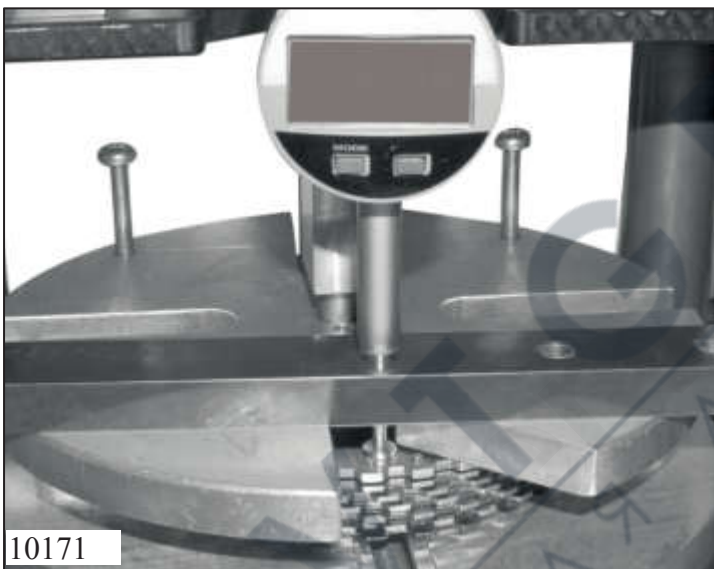

Place measuring beam with dial gage on piston B. Place measuring sensor on piston A. Set dial gage to "0" and find dimension to the top of the snap ring groove.

Repeat measurement at 3 places and find measurements.

$$M_1 = 23.00 \text{ mm,}$$

$$M_2 = 23.02 \text{ mm,}$$

$$M_3 = 23.03 \text{ mm}$$

Average value

$$\Leftrightarrow M_{ASR} = 23.02 \text{ mm}$$

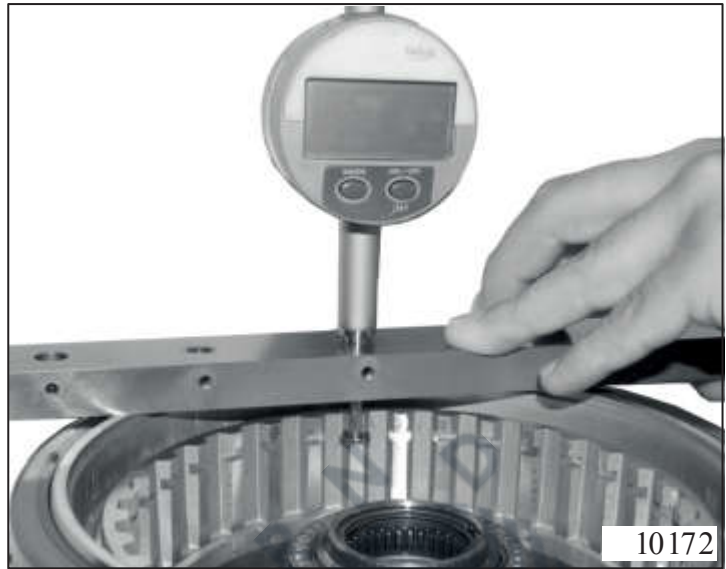
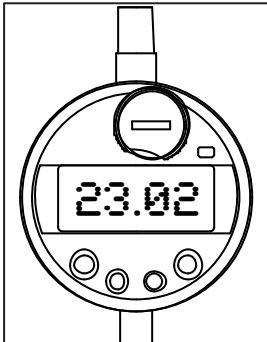

Measuring sensor thickness:

$$M_{MT} = 1.80 \text{ mm}$$

$$M_{AZYL} = M_{ASR} + M_{MT}$$

$$M_{AZYL} = 23.02 + 1.8 \text{ [mm]}$$

$$M_{AZYL} = 24.82 \text{ mm}$$

$$M_A = M_{AZYL} - M_{ALP}$$

$$M_A = 24.82 - 20.78 \text{ mm}$$

$$M_A = 4.04 \text{ mm}$$

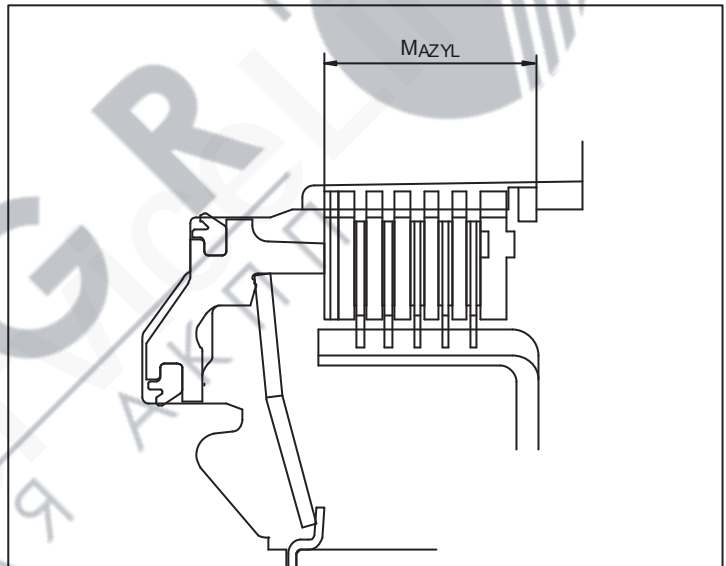

Thickness of snap ring

$$M_{ASP} = 2,0 \text{ mm}$$

Air clearance:

$$M_{ALS \text{ Act}} = M_A - M_{ASP}$$

$$M_{ALS \text{ Act}} = 4.04 - 2.0 \text{ [mm]}$$

$$M_{ALS \text{ Act}} = 2.04 \text{ mm}$$

Adjustment specification 1087.700.039

(fitted with 5 lining disks)

$$M_{ALS \text{ Des}} = 1.66 \text{ to } 1.95 \text{ mm}$$

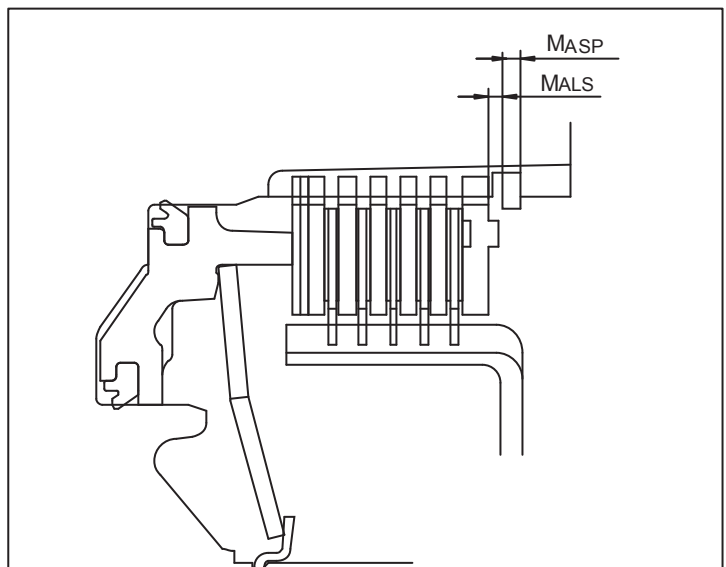



⇒ Snap ring thickness  $M_{ASP}$  of 2.0 mm  
= Inadequate.

New snap ring thickness 2.2 mm

$M_{ALS Act} = 4.04 - 2.20$  [mm]

$M_{ALS Act} = 1.84$  mm

⇒ Snap ring thickness  $M_{ASP}$  of 2.2 mm  
= OK.





#### 1.4.6 Brake B air clearance adjustment

(Adjustment specification 1087.700.096)

Multidisk package consists of following:  
a coil spring followed by, alternately:  
external disk > lining disk and finally an  
end disk 5.1 mm).

$$\Leftrightarrow M_{BEL} = 5.1 \text{ mm}$$

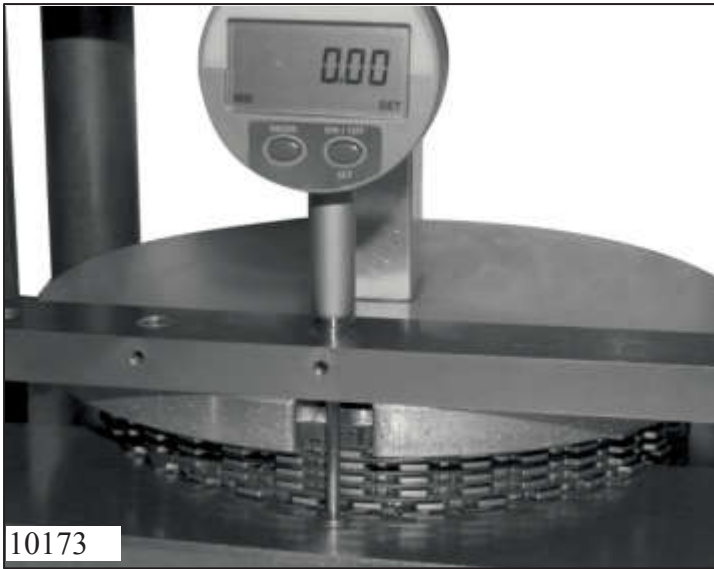

Place multidisk package into measuring unit, prestressing force = 500 N.

Place measuring beam with dial gage on pressure plate of the measuring unit.

Position on measuring sensor on base plate and set dial gage to "0".

Carry out measurement on multidisk package.

Read measurement

$$\Leftrightarrow M_{BLP} = 25.48 \text{ mm}$$

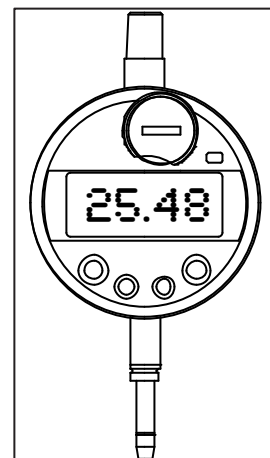
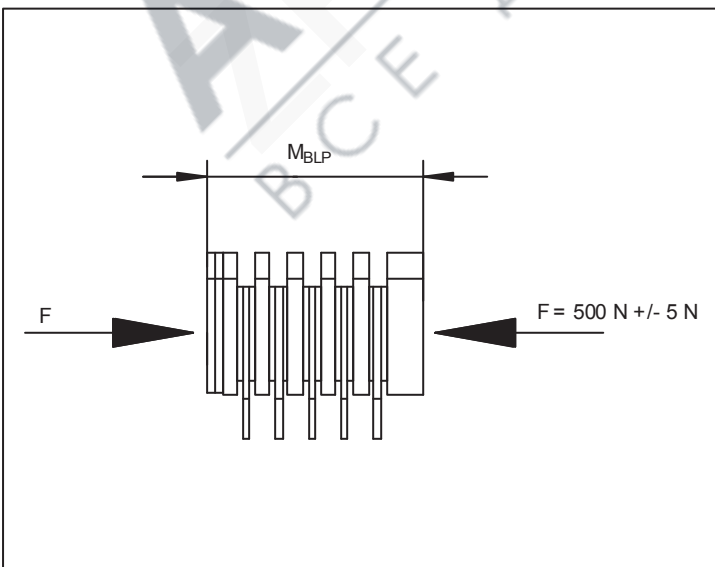
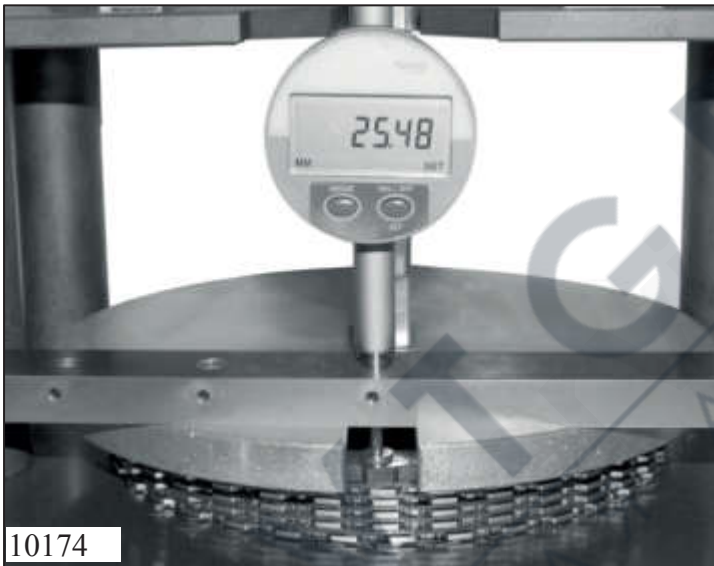

Place measuring beam with dial gage on flat surface and set gage to "0".

Place measuring beam on piston B and find depth for intermediate plate flat surface.

Piston B must be free of oil and rest firmly on surface.

Read measurement

$$\Leftrightarrow M_{BZYL} = 33.47 \text{ mm}$$

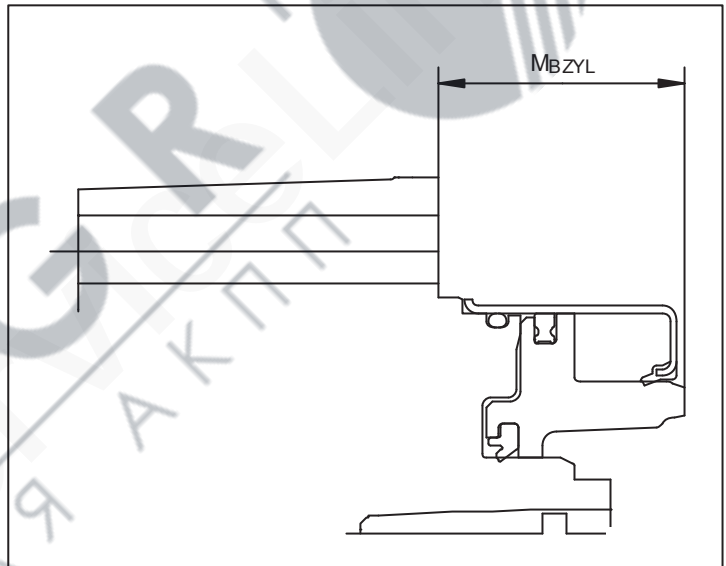
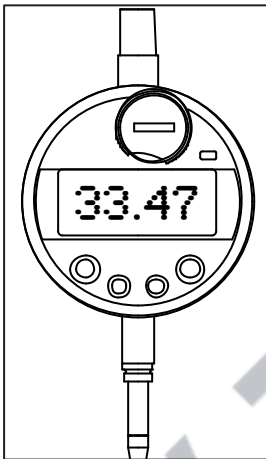

Fixed dimension from adjustment specification transmission housing package space  $61.0 + 0.1$  mm.

Average value

$$\Leftrightarrow M_{BBR} = 61.05 \text{ mm}$$

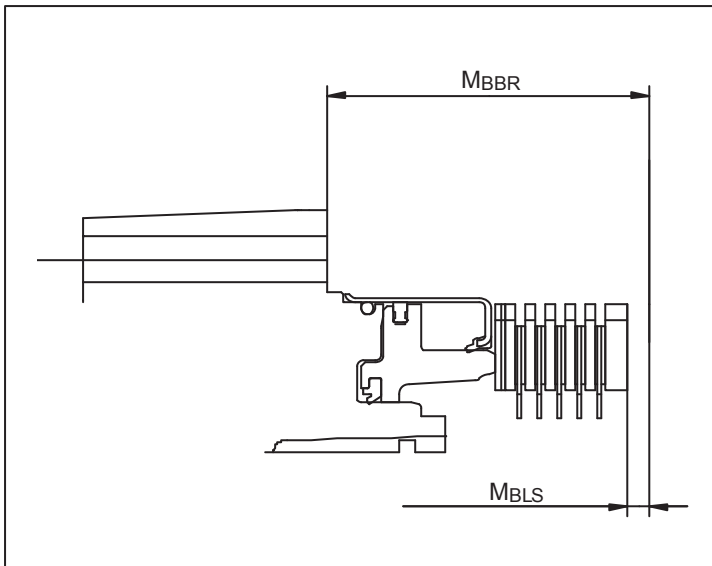

Air clearance:

$$M_{BLS \text{ Act}} = M_{BBR} - M_{BZYL} - M_{BLP}$$

$$M_{BLS \text{ Act}} = 61.05 - 33.47 - 25,48 \text{ [mm]}$$

$$M_{BLS \text{ Act}} = 2.10 \text{ mm}$$

(Adjustment specification 1087.700.096)

$$M_{BLS \text{ Des}} = 1.71 \text{ to } 2.22 \text{ mm}$$

End disk  $M_{BEL}$  with 5.1 mm = OK.





*(Manual transmission only)*

### **1.4.7 Switch adjustment (locking spring)**

Set catch disk to position "N" (neutral)  
using a suitable tool or by hand.

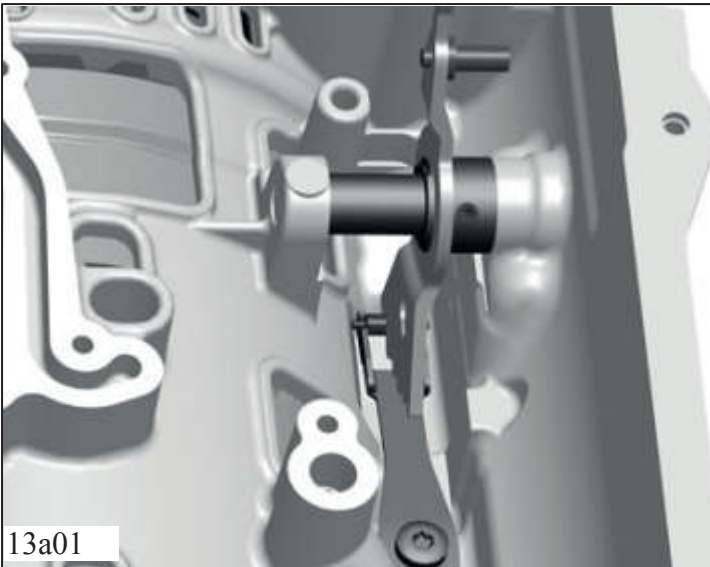

Align locking spring with fixing device  
AA00.600.175.

Tighten locking spring in this position.

Tighten screw on output side first.

(See section 1.5 for tightening torques)

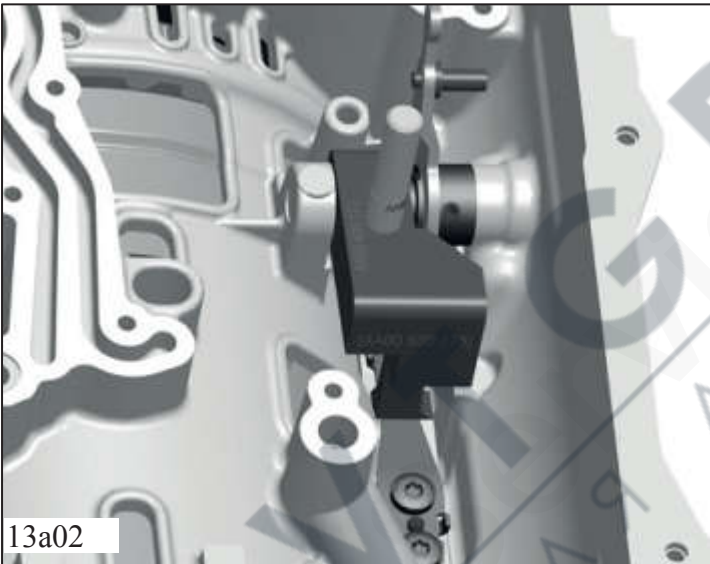

Then turn it through torsion angle using  
tool 5w04.000.583.

Remove centering device.

Cycle selector shaft through all positions  
and then remove it again.

(See section 1.5 for tightening torques)

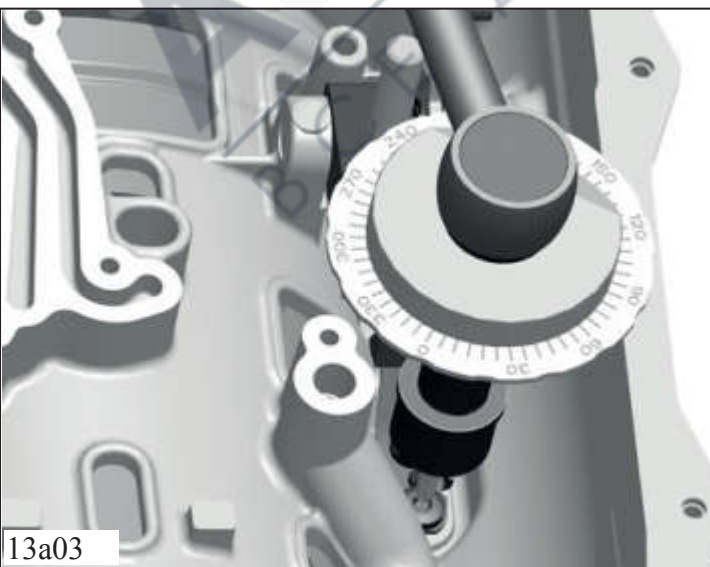





## 1.4.8 Bevel gear (front axle differential)

### 1.4.8.1 Pinion position

(Adjustment specification 1084.700.008)

Place measuring unit 5p01.003.652 in MIN-master 5p89.007.273 and adjust to fixed dimension as marked on MIN-master.

Fixed dimension:  
56.059 mm

Mit dem MAX-Meister wird gemessen.

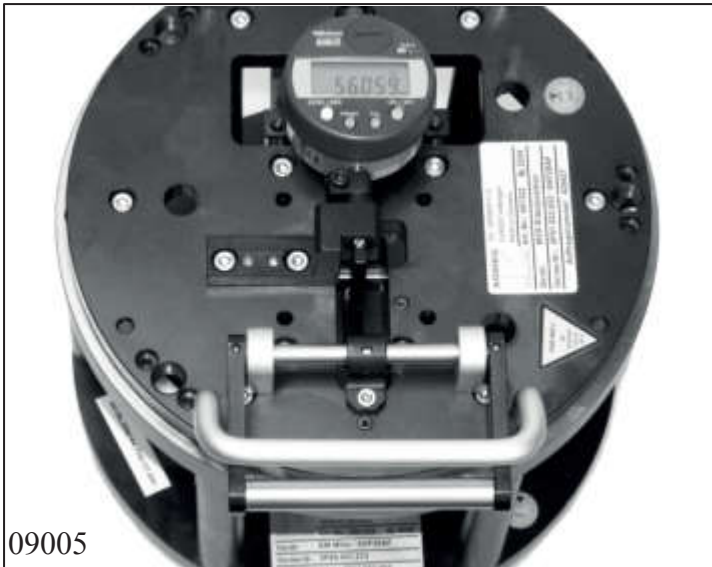

Insert auxiliary shaft 5p01.003.656 as far as possible into converter housing in a relaxed state.



Lock auxiliary shaft.

Insert measuring unit 5p01.003.652 into converter housing in a relaxed state.

The ball on the measuring sensor must engage in auxiliary shaft.

Read the measurement:  
 $M_{BR} = 56.021 \text{ mm}$

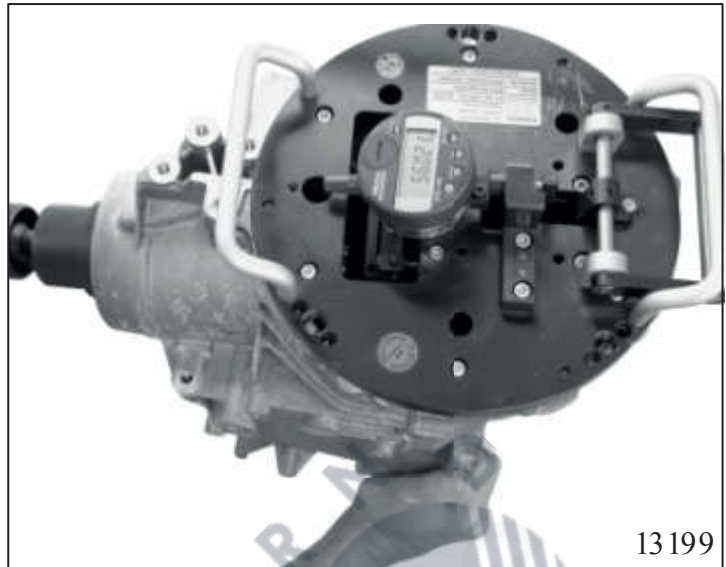

#### 1.4.8.2 Pinion shaft bearing design height

Place pinion shaft bearing (with collar upwards) on tool AA00.591.272.



Place tool AA00.591.272 on bearing and secure with with a wing nut in a positive connection.



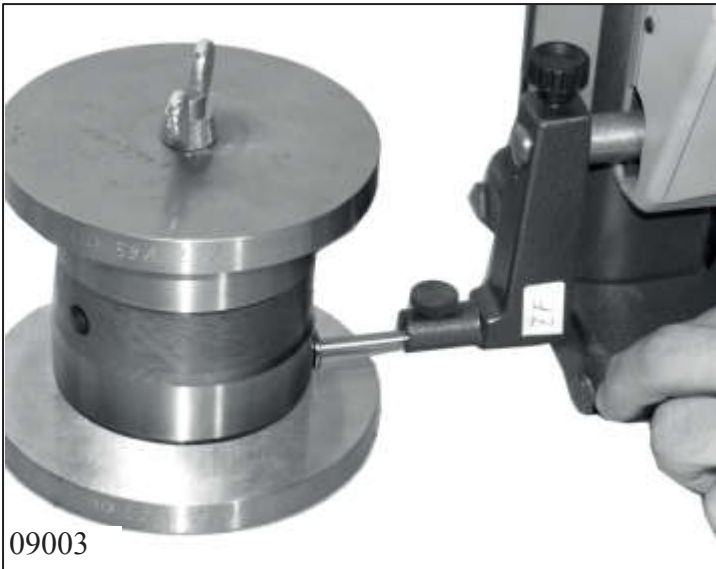

Find dimension from base plate to the support surface (under the collar) of the pinion shaft bearing using a height gage.

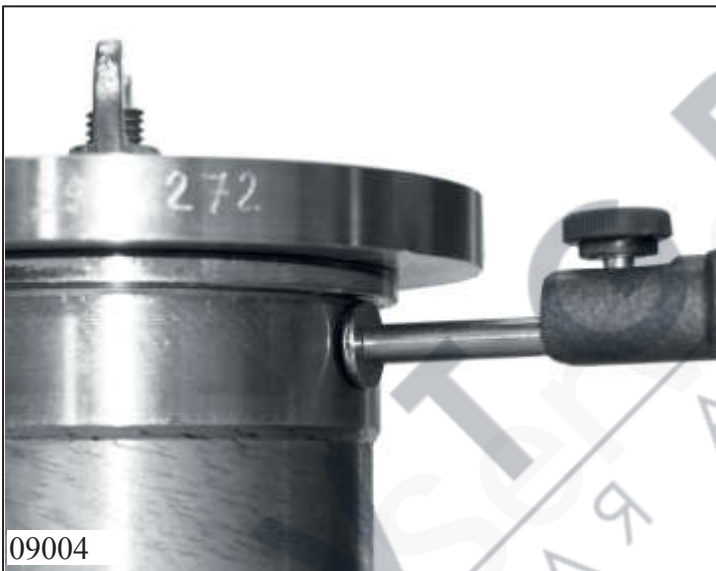

Read measurement:  
 $M_L = 76.97 \text{ mm}$

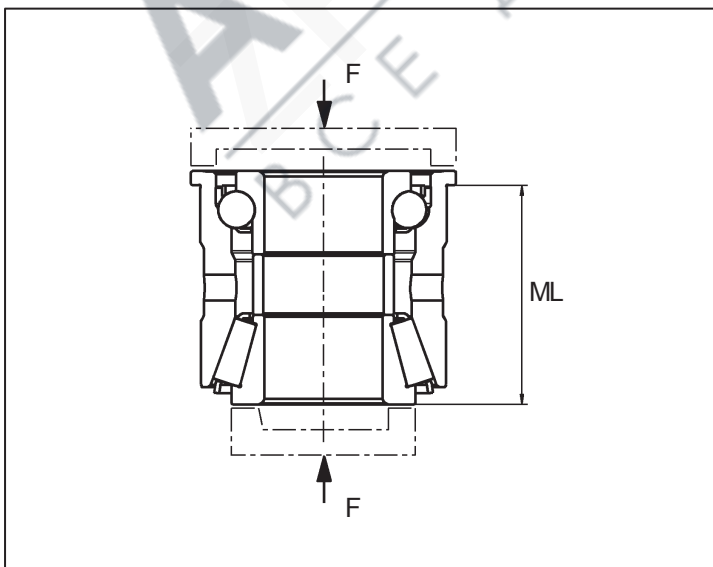

### 1.4.8.3 Regulations for the adjusting washer for the pinion shaft bearing

$$G_R = M_{BR} + M_{HW}$$

$$M_{HW} = 117.386 \text{ mm (aux. shaft dimension)}$$

$$G_R = 56.021 + 117.386 \text{ [mm]}$$

$$G_R = 170.79 \text{ mm}$$

$$R = 95.00 \text{ mm}$$

(engraved pinion shaft dimension)

$$R_K = -0.05 \text{ mm}$$

(correction value pinion installation)

$$L_K = 0.022 \text{ mm}$$

(correction value bearing design height)

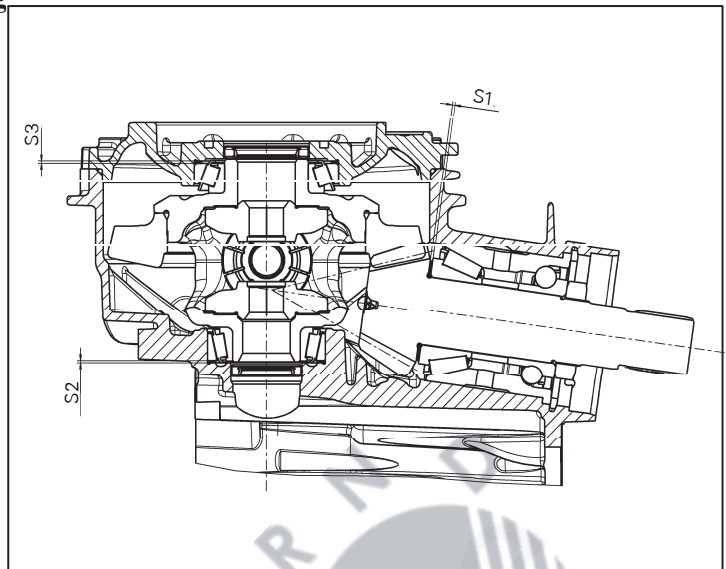

$$S_B = \text{washer cross-section}$$

$$S_B = G_R - R - R_K - M_L - L_K$$

$$S_B = 170.79 - 95 - (-0.05) - 76.97 - 0.022$$

$$S_B = 1.465 \text{ mm}$$

Select disk thickness:

$$\Rightarrow S_1 = 1.475 \text{ mm}$$

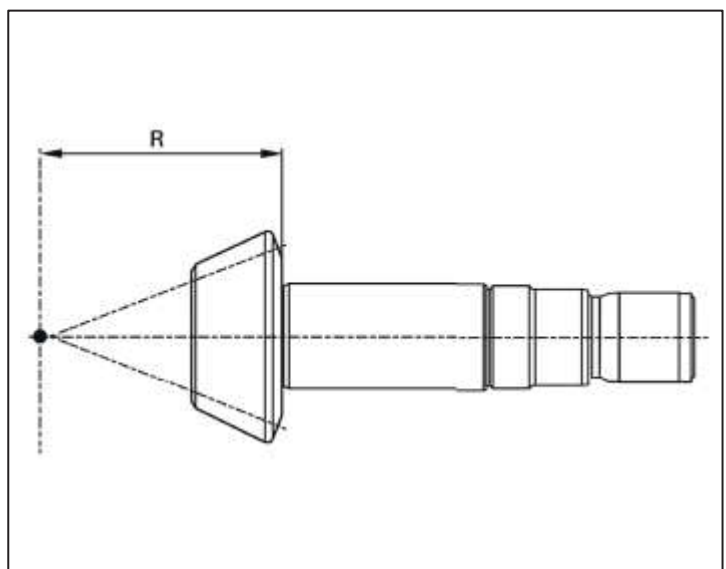
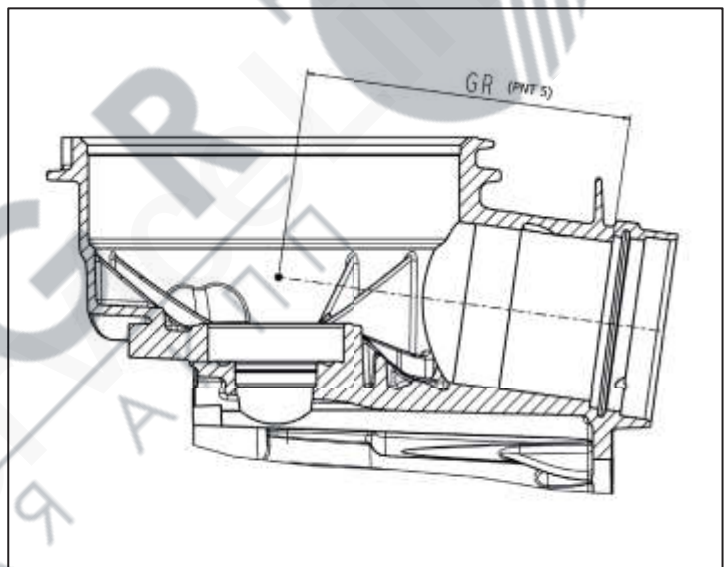

#### 1.4.8.4 Crown gear position torsional clearance



Install bearing shells (35.060/130) and existing shim  $S_3$  (35.140) in differential cover.

Install bearing shell (35.060/120) and existing shim  $S_2$  (35.130) in converter housing.

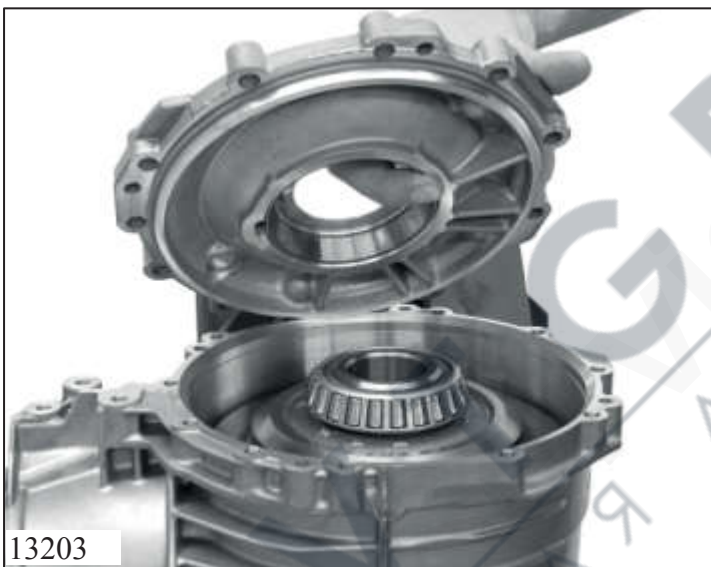

Insert differential (35.060) into converter housing.

Secure bearing shell in differential cover.

Position differential cover and tighten it with 4 screws (35.170) crosswise.

Tightening torque: 27.0 Nm  $\pm$  2.7 Nm

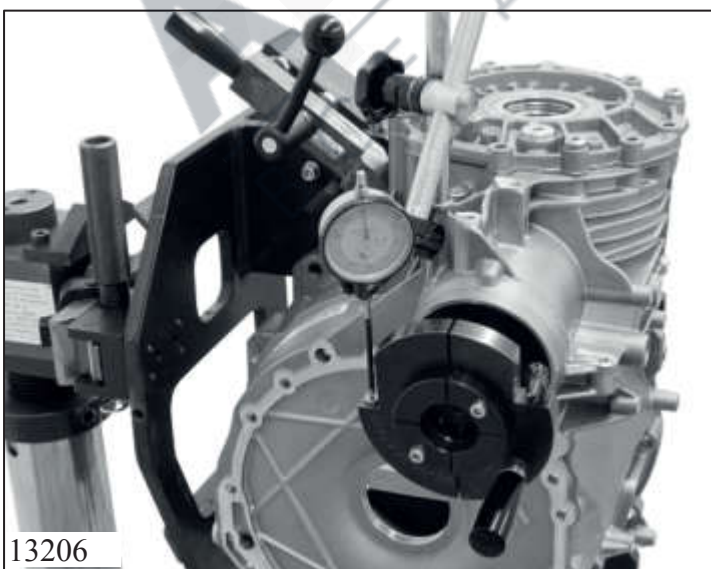

Place torsion clearance measuring disk 5p01.000.994 on pinion shaft and secure it.

Screw post on measuring stand 5p01.000.347 into transmission housing and secure lateral hold-down device with measuring sensor is perpendicular to market measurement area of measuring disk.

Turn pinion shaft one way against pinion / crown gear tooting.  
Set dial to "0".

Carefully turn pinion shaft opposite way as far as possible.

Find measurement

⇨  $M_V$

Under specification 1084.700.008 edge clearance  $M_V$  must be between 0.26 and 0.46 mm with a defined radius (toothing ratio 11/34).

Read measurement:

$M_{V Ac} = 0.44 \text{ mm}$

$M_{V Des} = 0.26 \text{ to } 0.46 \text{ mm}$

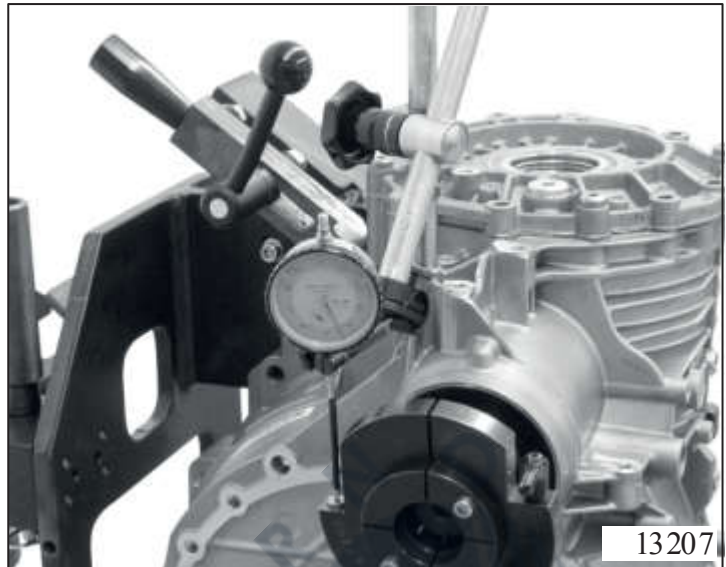

#### 1.4.8.5 Differential prestressing

Place measuring plate 5p89.000.072 on differential cover.

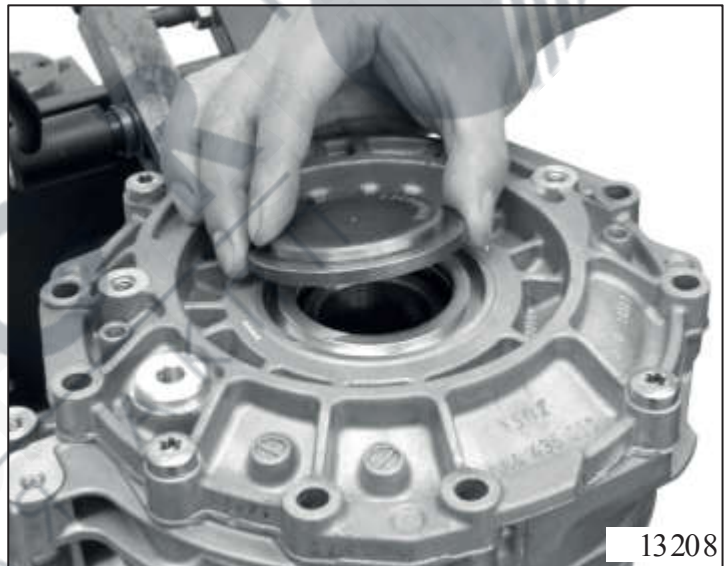

Screw post on measuring stand 5p01.000.347 with an M8 thread into a suitable thread in transmission housing.

Secure cross hold-down device with dial gage sensor is aligned to the center and perpendicular to measuring plate.

Set dial gage to "0".



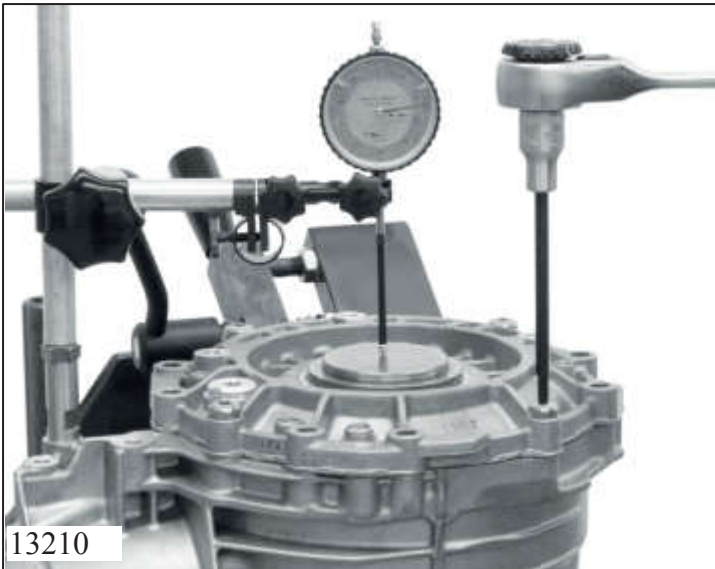

Undo 4 screws ½ turn each crosswise until screws are loose and dial gage does not change any longer.

Find measurement

$$\Rightarrow M_E$$

Read measurement  $M_{E}$ :

$$M_{E \text{ Act}} = 0.24 \text{ mm}$$

$$M_{E \text{ Des}} = 0.18 \text{ to } 0.28 \text{ mm}$$

**Both washer thicknesses ( $S_2$  and  $S_3$ ) are OK.**

*Assumption: if  $M_{V \text{ Act}} > 0.46 \text{ mm}$*

Reduce size of shim  $S_2$  and enlarge  $S_3$  by same thickness.

Repeat measurement.

*Assumption: if  $M_{E \text{ Act}} > 0.28 \text{ mm}$*

Reduce size of shim  $S_3$ , leave  $S_2$ .

Repeat measurement.

### 1.4.9 Transmission clearance and front axle output

Find:

#### Transmission clearance shim $S_6$

See adjustment specification: 1091.700.043

#### Front axle output shim $S_4$

See adjustment specification: 1087.700.006

#### Drive wheel shim $S_5$

See adjustment specification: 1091.700.043

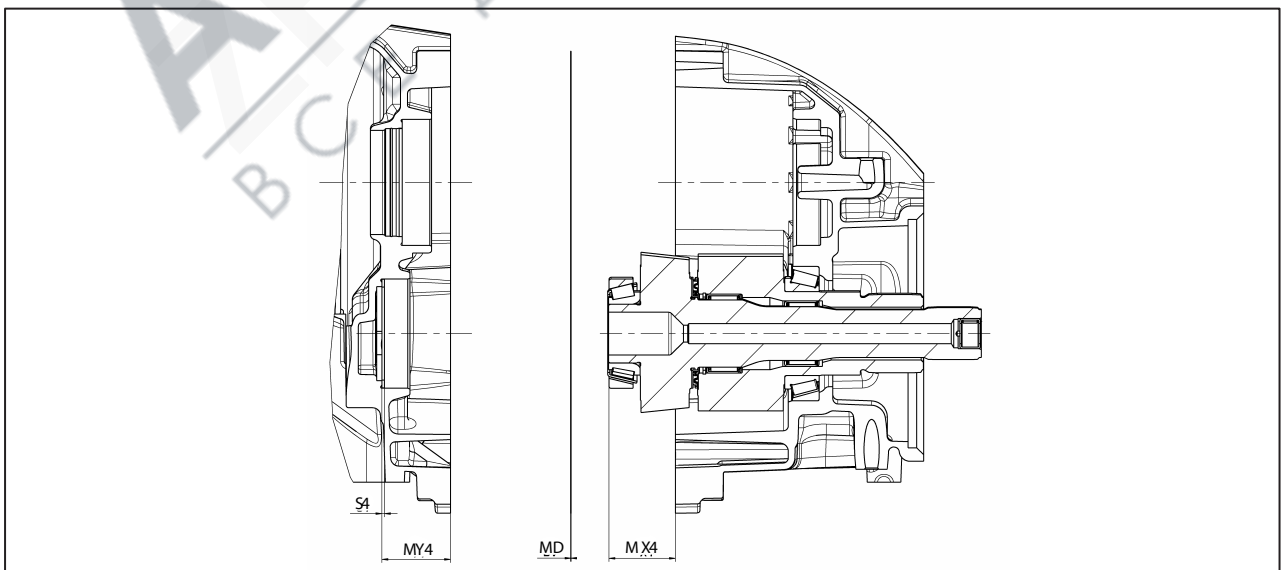
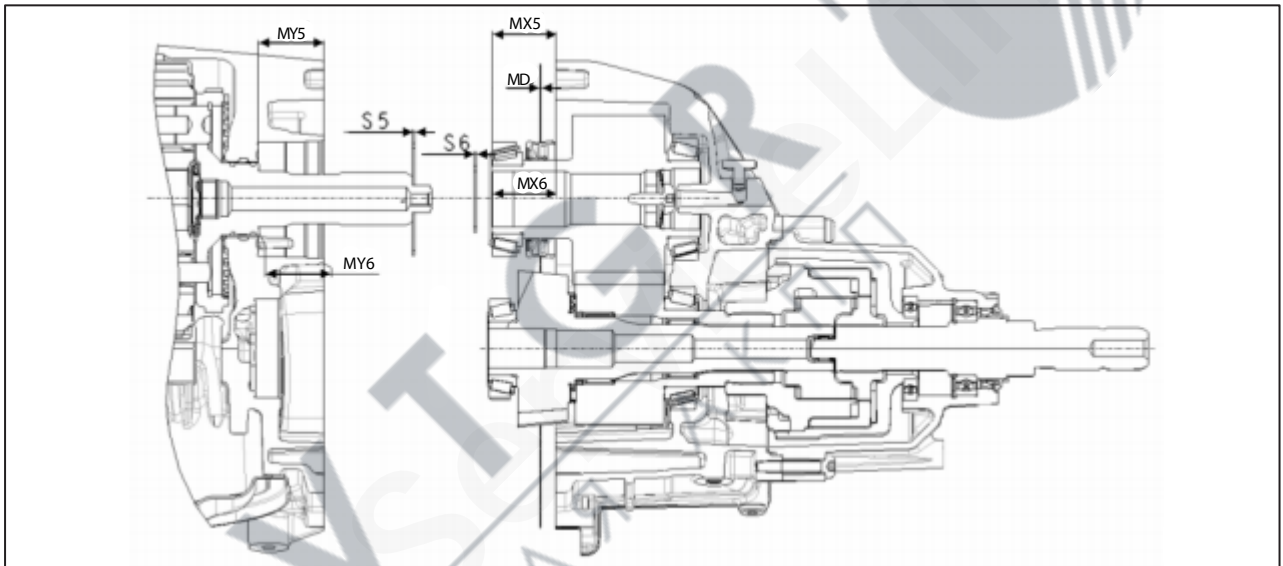



*Measurement on intermediate housing:*

Place intermediate housing in mounting device 5p74.000.099.

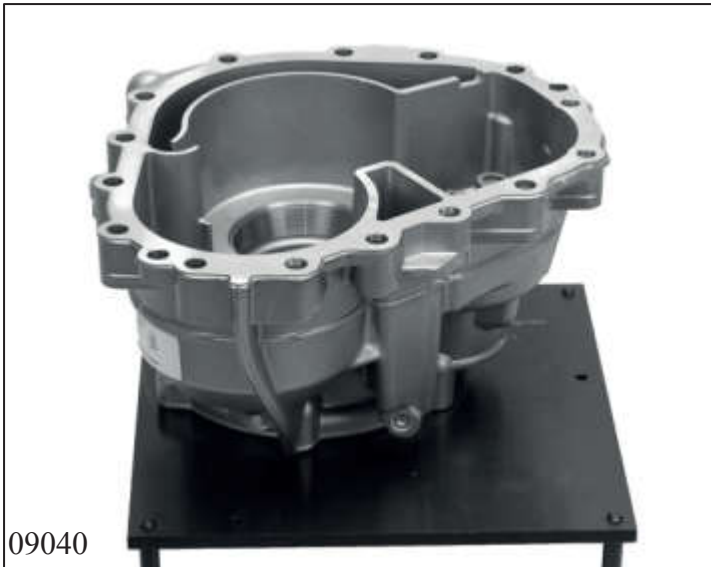

Fit drive wheel and front axle shaft with output gear in intermediate housing.



Place bearing shells on tapered roller bearing on front axle shaft and drive wheel.

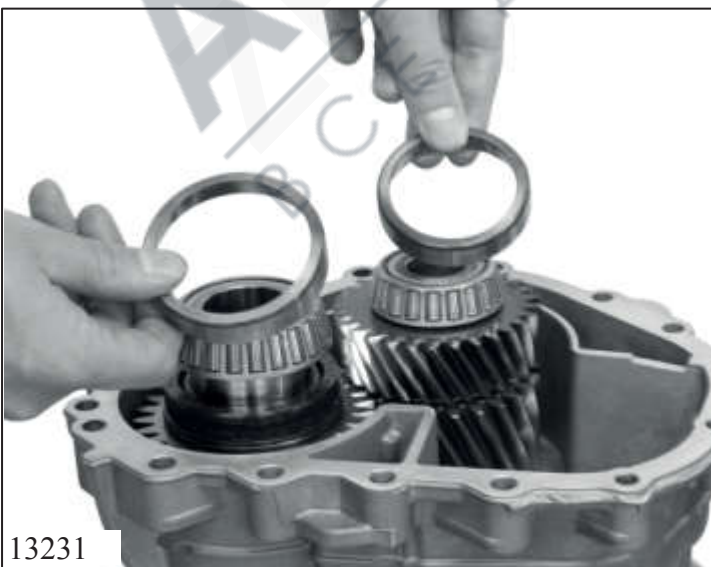

**NOTICE**

For adjustment work,  
use steel screws.

Place measuring plate of 5p01.000.973  
on intermediate housing and secure it  
with 11 screws M8x40.

Tightening torque:  $27.0 \pm 2.7$  Nm

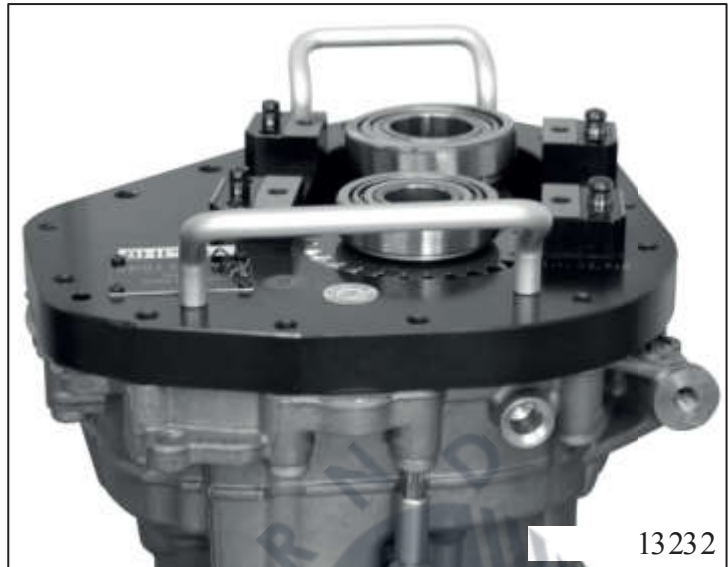

13232

Secure measuring bridge B with 2 dial  
gages from tool 5p01.000.973 on setting  
master MIN AA00.549.233.



13233

Set dial gages to fixed dimension (setting  
master):

- 0,290 mm (transmission clearance)
- 0,340 mm (drive wheel)

Unscrew measuring bridge B from setting  
master.



13234



Secure measuring bridge B to setting master MAX 5p89.007.767 and check measurement and sign.

Desired value:

0.549 mm (transmission clearance)  
0,399 mm (drive wheel)

Unscrew measuring bridge B from setting master MAX.

13236

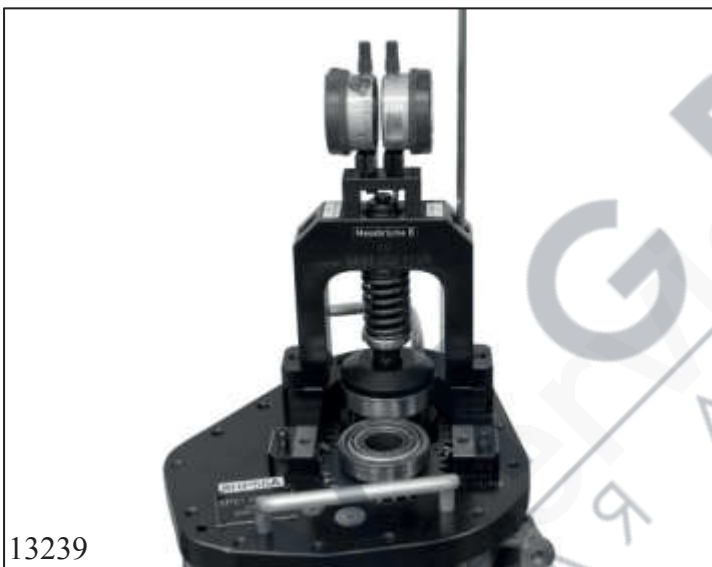

Position measuring bridge over drive wheel and secure it.

Turn output gear until the dial gage indicator no longer changes.

13239



Read measurements:

$$M_{W5} = -0.314 \text{ mm}$$

$$M_{W6} = 0.047 \text{ mm.}$$

Measuring plate thickness

$$M_{PL1} = 41.093 \text{ mm}$$

*This means:*

$$M_{X5} = M_{PL1} + M_{W5} \\ = 41.093 + (-0.314) \text{ [mm]}$$

$$M_{X5} = \mathbf{40.779 \text{ mm}}$$

$$M_{X6} = M_{PL1} + M_{W6} \\ = 41.093 + (0.047) \text{ [mm]}$$

$$M_{X6} = \mathbf{41.140 \text{ mm}}$$

Unscrew measuring bridge B.

13240

Secure measuring bridge A (one dial gage) from tool 5p01.000.973 on setting master MIN AA.549.233.

Set dial gage to fixed dimension (setting master):

-0.340 mm

Unscrew measuring bridge A from setting master MIN.



Secure measuring bridge A on setting master MAX.

Check measurement and sign.

Desired value:

0.399 mm

Unscrew measuring bridge A from setting master MAX.



Position measuring bridge A over front axle shaft and secure it.

Turn output gear until the measurement no longer changes.





Read measurement:

$$M_{W4} = 0.101 \text{ mm}$$

Measuring plate thickness

$$M_{PL2} = 38.718 \text{ mm}$$

*This means:*

$$M_{X4} = M_{PL2} + M_{W4}$$

$$= 38.718 + (0.101) \text{ [mm]}$$

$$M_{X4} = \mathbf{38.819 \text{ mm}}$$

Unscrew measuring bridge A from measuring plate.

Unscrew measuring plate from intermediate housing.

13245

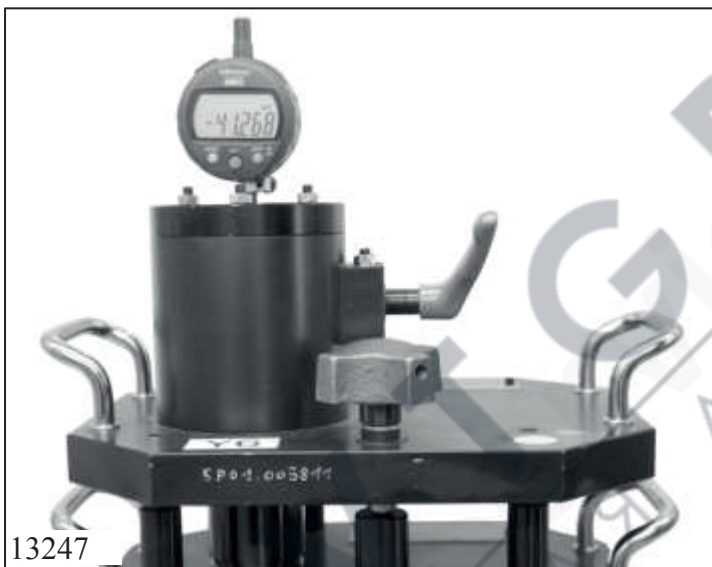

*Measurement on transmission housing:*

Place measuring device 5p01.003.811 on setting master MIN 5p89.007.918 and set the fixed dimension:

$$-41.268 \text{ mm}$$

Spring mechanism is to be activated for this purpose.

Unscrew measuring device.

13247

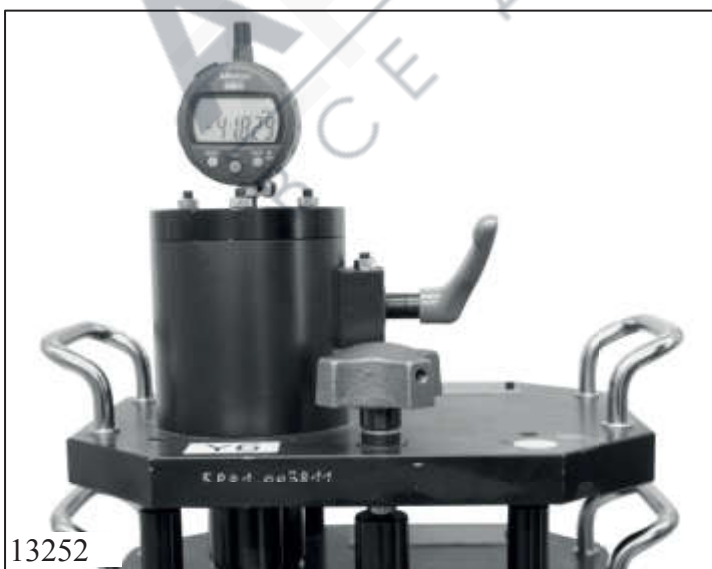

Place measuring device on setting master MAX 5p89.007.919 and check fixed dimension:

$$-41.829 \text{ mm}$$

Spring mechanism is to be activated for this purpose.

13252

Place measuring device 5p01.000.972 on setting master MIN 5p89.007.765 and set fixed dimension:

Left = -41.592 mm  
 Right = -39.797 mm



13248

Place measuring device on setting master MAX 5p89.007.766 and check fixed dimension:

Left = -42.357 mm  
 Right = -39.905 mm



13251

Secure measuring device 5p01.003.811 to transmission housing and activate spring mechanism.

Read measurement:

$$M_{Y6} = 42.805 \text{ mm}$$

Unscrew measuring device from transmission housing.



13249

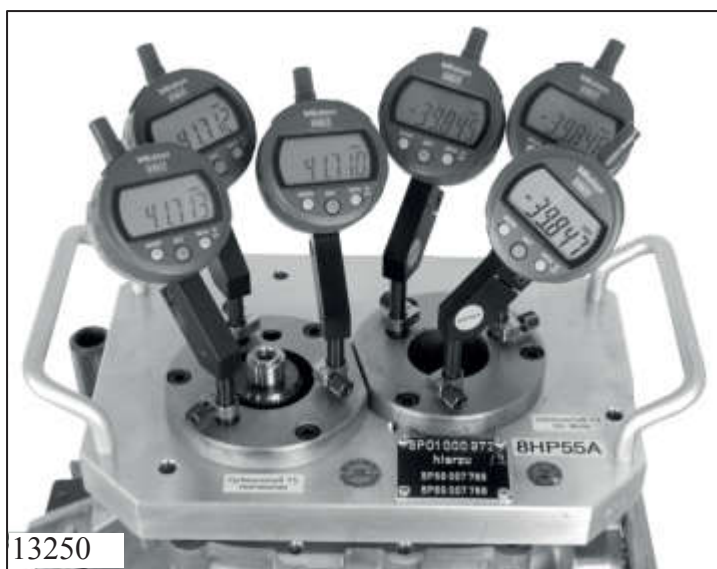

Place measuring device 5p01.000.972 on transmission housing.

Read measurements:

$$M_{Y4} = (M_{Y41} + M_{Y42} + M_{Y43}) / 3$$
$$M_{Y4} = -39.847 \text{ mm}$$

$$M_{Y5} = (M_{Y51} + M_{Y52} + M_{Y53}) / 3$$
$$M_{Y5} = -41.712 \text{ mm}$$

### Determining the washer thickness of transmission clearance $S_6$

(Figure 001, Page 1.4/40)

Package space

$$B_6 = M_{Y6} + M_D - M_{X6}$$

$M_D = \text{Seal dimension} = 0.365 \text{ mm}$

$$B_6 = 42.805 + 0.365 - 41.140 \text{ [mm]}$$

**= 2.03 mm**

Transmission clearance  $_{Des}$ :  
0.185 - 0.265 mm

Washer thickness  $S_6$

$$S_6 = B_6 - \text{Transmission clearance}_{AV}$$
$$S_6 = 2.03 - 0.225 \text{ [mm]}$$

Select disk thickness:

⇒  **$S_6 = 1.80 \text{ mm}$**

### Determining the washer thickness of drive wheel $S_5$

(Figure 001, Page 1.4/40)

Drive wheel package space

$$B_5 = M_{Y5} + M_D - M_{X5} - M_{K5}$$

$M_{K5} = \text{Correction value} = 0.06 \text{ mm}$

$$B_5 = 41.712 + 0.365 - 40.779 - 0.06 \text{ [mm]}$$

**= 1.238 mm**

Prestressing  $_{Des}$ : -0.06 to 0.01 mm

Washer thickness  $S_5$

$$S_5 = B_5 - \text{Prestressing}_{Average \text{ value}}$$
$$S_5 = 1.238 - (-0.035) \text{ [mm]}$$

Select disk thickness:

⇒  **$S_5 = 1.25 \text{ mm}$**

### Determining the washer thickness of front axle output $S_4$

(Figure 002, Page 1.4/40)

Front axle output package space

$$B_4 = M_{Y4} + M_D - M_{X4} - M_{K4}$$

$M_{K4} = \text{Correction value} = 0.08 \text{ mm}$

$$B_4 = 39.847 + 0.365 - 38.819 - 0.08 \text{ [mm]}$$

**= 1.313 mm**

Prestressing  $_{Des}$ : -0.07 to 0.02 mm

Washer thickness  $S_4$

$$S_4 = B_4 - \text{Prestressing}_{AV}$$
$$S_4 = 1.313 - (-0.045) \text{ [mm]}$$

Select disk thickness:

⇒  **$S_4 = 1.35 \text{ mm}$**



## 1.5 Tightening torques

No.	SDM-Item No.	Designation	Wrench size No.	Page	Tightening torque
1.	06.170	Torx screw M6x13 (Locking spring M type)	T27H	1.4/23	11.0 Nm (± 1,1 Nm)
2.	01.100	Sealing screw M10x1 (Transmission housing PZT)	Hexagon socket Size = 5 mm	3.1/3	8.0 Nm (± 0,8 Nm)
3.	01.180	Sealing screw M22x1.5 (Oil filling)	Hexagon socket Size = 10 mm	3.1/3	30.0 Nm (± 3,0 Nm)
4.	24.120	Torx screws M6x20 (Guide plate)	T27	3.1/4	10.0 Nm (± 1,0 Nm)
5.	10.110	Torx screws M6x24 (Intermediate plate)	T40	3.3/10 3.3/11	4.0 Nm + 90° ± (0.5 Nm + 5°)
6.	10.120	Torx screw M6x39 (Centering plate)	T40	3.3/11	10.0 Nm (± 1,0 Nm)
7.	10.230	Torx screws M8x74 (Oil supply)	T50	3.4/3	10.0 Nm + 90° ± (1.0 Nm + 5°)
8.	28.450	Torx screws M6x59 (Mechatronic unit)	T40	3.5/2 3.5/3	8.0 Nm (± 0,8 Nm)
9.	28.570	Torx screws M6x20 (Mechatronic unit)	T40	3.5/3	8.0 Nm (± 0,8 Nm)
10.	28.450 28.570	<i>Torx bolts (Oil reservoir)</i>	<i>T40</i>	3.5/4	8.0 Nm (± 0,8 Nm)
11.	28.580	Torx screw M6x20 (Wiring loom)	T40	3.5/4	8.0 Nm (± 0,8 Nm)
12.	28.650	Torx screw M6x19.5 (Guide sleeve)	T40	3.5/5	5.5 Nm (± 0,55 Nm)
13.	03.030	Torx screws M6x19.5 (Oil pan)	T40	3.5/6	4.0 Nm + 45° ± (0.5 Nm + 5°)
14.	03.010/ 015	Sealing screw M10x1 (Oil drain screw)	Hexagon socket Size = 5 mm	3.5/6	12.0 Nm (± 1,2 Nm)
15.	35.080	Nut M40x1,5 (pinion shaft) LH	Size = 55 mm	3.6/3	Tightening torque: 120.0 Nm ± 1.0 Nm und 26° ± 1°  Check value: 380 Nm bis 650 Nm
16.	35.080	Nut M40x1,5 (pinion shaft) <i>Info: Right-hand thread available in older master parts lists</i>	Size = 55 mm	3.6/3	750 Nm (± 5%)
17.	35.270	Sealing screw M10x1 (Oil drain screw front axle)	Hexagon socket Size = 5 mm	3.6/3	8.0 Nm (± 0,8 Nm)

No.	SDM-Item No.	Designation	Wrench size No.	Page	Tightening torque
18.	35.050	Torx screw M6x14 (Hold-down device)	T27	3.6/5	8.0 Nm (± 0,8 Nm)
19.	35.170	Torx screws M8x39 (Differential cover)	T40	3.6/6	see page 1.3/2
20.	35.172	Torx screw, coated (Differential cover)	T40	3.6/6	see page 1.3/2
21.	35.400	Sealing screw M1 8x1.5 (Oil filler plug front axle)	Hexagon socket Size = 8 mm	3.6/7	27.0 Nm ± (2.7 Nm)
22.	35.240	Torx screws M8x22 (Converter housing)	T40	3.6/9	9.0 Nm + 60° ± (1.0 Nm + 5°)
23.	35.250	Torx screw M1 0x27 (Converter housing)	T40	3.6/9	16.0 Nm ± (1.6 Nm)
24.	97.030	Hexagonal screw (Converter retaining bracket)	Size = 17 mm	3.6/10	15.0 Nm ± (1.5 Nm)
25.	97.020	Hexagonal screw and nut (Converter retaining bracket)	Size = 17 mm	3.6/10	15.0 Nm ± (1.5 Nm)
26.	35.210	Torx screws M8x22 (Flanged shaft)	T40	3.6/11	9.0 Nm + 60° ± (1.0 Nm + 5°)
27.	37.200	Torx screws M6x25 (Pump)	T40	3.7/2	10.0 Nm ± (1.0 Nm)
28.	37.020	Torx screws M8x29 (Side shaft)	T40	3.7/4	25.0 Nm ± (2.5 Nm)
29.	37.266	Torx screw M8x1 8 (Drive wheel)	T50	3.7/8	20.0 Nm ± (2.0 Nm)
30.	37.300	Torx screws M8x40 (Intermediate housing)	T40	3.7/10	See page 1.3/2
31.	37.320	Torx screws M10x47 (Intermediate housing)	T40	3.7/10	See page 1.3/2
32.	37.070/ 130	Sealing screw M12x1.5 (Oil drain screw rear axle)	Hexagon socket Size = 5 mm	3.7/10	12.0 Nm ± (1.2 Nm)
33.	36.120	Sealing screw M1 8x1.5 (Oil filler plug front axle)	Hexagon socket Size = 8 mm	3.8/3	27.0 Nm ± (2.7 Nm)
34.	36.080	Torx screws M8x40 (Distribution housing)	T40	3.8/4	10.0 Nm + 90° ± (1.0 Nm + 5°)
35.	36.100	Torx screw M8x20 (Vibration damper)	T40	3.7/8	28.0 Nm ± (2.8 Nm)

## 1.6 Transmission test

The following must be tested:

### 1. Perfect oil level

Correct oil level, refer to the specifications of vehicle manufacturer and list of lubricants TE-ML 11 (Serviceline) and SDM.

### 2. Oil level too low

There may be the following consequences:

- Engine over-revving or no traction when cornering or moving off
- Valve screech caused by air inclusions in the oil
- General malfunctions

The results may include the clutches burning out.

### 3. Oil level too high

Danger of heavy adulteration, foaming, major temperature increases when driving at high speed. Oil loss through vent, consequences may be burned clutches and gearshift problems.

### 4. Perfect engine adjustment

Correct idling speed, refer to the vehicle manufacturer's specifications.

### 5. Traction forwards and backwards



Correct gearshift linkage or cable adjustment, refer to the vehicle manufacturer's specifications.



### 6. Radiator short-circuit or radiator connection on the test bed



Do not overheat the transmission, max. 120°C.



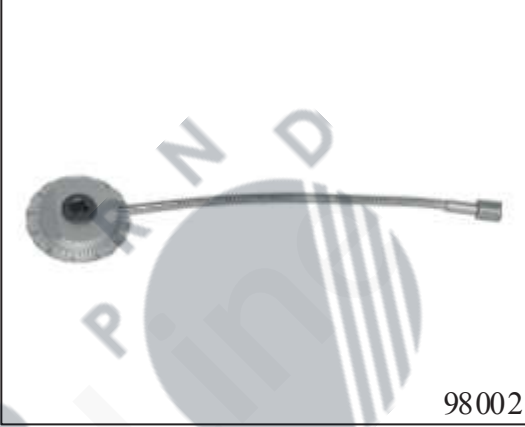

1.7 Special tools



ITEM	Order No. / Purpose	Comment
<p style="text-align: center;">E 1</p>  <p>98008</p>	<p>5p01.000.329 Measuring device multidisk package (crusher gage)</p>	<p>identical 4 HP 20 -- 8 HP</p>
<p style="text-align: center;">E 2</p>  <p>98034</p>	<p>5p01.000.330 Multidisk package measuring device (clutch clearance)  (Measuring plate: multidisk package thickness - short neck &gt; 20 mm - long neck &lt; 20 mm)</p>	<p>identical 4 HP 20 -- 8 HP</p>
<p style="text-align: center;">E 3</p>  <p>97301</p>	<p>5p01.001.458 Multidisk package measuring device (prestressing)</p>	<p>identical 4 HP 18 Q -- 8 HP</p>



Comment	Order No. / Purpose	ITEM
<p>identical</p> <p>6 HP 19/A/X -- 8 HP</p>	<p><i>Manual transmission only:</i></p> <p>5w04.000.583 Torsion measuring device assembly locking spring</p>	<p>E 4</p>  <p>98002</p>
<p>identical</p> <p>8 HP 55 A 8 HP 55 FL</p>	<p>5p01.000.972 Measuring device for transmission housing bearing depth / bearing adjustment (2 measurement points)</p>	<p>E 5</p>  <p>13261</p>
<p>identical</p> <p>8 HP 55 A 8 HP 55 FL</p>	<p>5p89.007.765 Setting master for transmission housing bearing depth / bearing adjustment (2 measurement points)</p>	<p>E 6</p>  <p>13262</p>

ITEM	Order No. / Purpose	Comment
<p data-bbox="422 421 469 450">E 7</p>  <p data-bbox="188 864 268 896">13263</p>	<p data-bbox="767 427 1219 573">5p89.007.766 Setting master MAX transmission housing bearing depth / bearing adjustment (2 measurement points)</p>	<p data-bbox="1262 427 1374 456">identical</p> <p data-bbox="1262 501 1414 568">8 HP 55 A 8 HP 55 FL</p>
<p data-bbox="422 981 469 1010">E 8</p>  <p data-bbox="188 1426 268 1458">13254</p>	<p data-bbox="767 987 970 1055">5p01.003.656 Auxiliary shaft</p>	<p data-bbox="1262 987 1374 1016">identical</p> <p data-bbox="1262 1061 1414 1167">6 HP 28 AF -- 8 HP 55 A</p>
<p data-bbox="422 1541 469 1570">E 9</p>  <p data-bbox="188 1986 268 2018">13332</p>	<p data-bbox="767 1552 1059 1619">AA00.591.272 Mount double bearing</p>	<p data-bbox="1262 1552 1374 1581">universal</p>



Comment	Order No. / Purpose	ITEM
<p>identical</p> <p>8 HP 55 A 8 HP 55 FL 8 HP 90 A 8 HP 90 A 74</p>	<p>5p01.000.994 Measuring device Torsion clearance</p>	<p>E 10</p>  <p>13333</p>
<p>identical</p> <p>8 HP 55 A 8 HP 55 FL 8 HP 90 A 8 HP 90 A 74</p>	<p>5p01.000.347 Measuring stand Axial torsion transmission clearance</p>	<p>E 11</p>  <p>13255</p>
<p>identical</p> <p>6 HP 28 AF -- 8 HP 55 A 8 HP 55 FL 8 HP 90 A 8 HP 90 A 74</p>	<p>5p89.000.072 Measuring device Prestressing differential cover</p>	<p>E 12</p>  <p>13271</p>

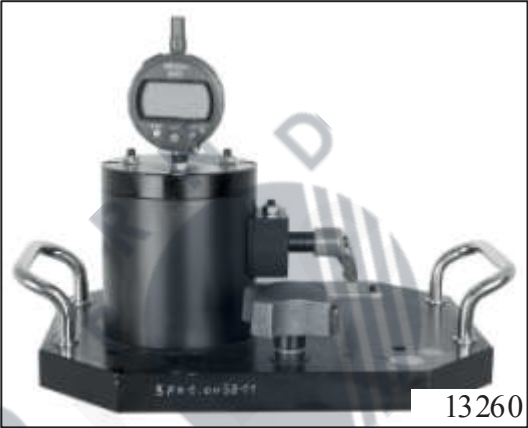







ITEM	Order No. / Purpose	Comment
<p style="text-align: center;">E 13</p>  <p style="text-align: center;">13270</p>	<p>5p01.000.973            (Measuring bridge A = 1 dial gage)            (Measuring bridge B = 2 dial gages)            Measuring device front axle            manual with measuring bar</p>	<p>identical            8 HP 55 A            8 HP 55 FL</p>
<p style="text-align: center;">E 14</p>  <p style="text-align: center;">13257</p>	<p>AA00.549.233            Setting master MIN            Measuring device front axle            manual with measuring bar</p>	<p>identical            8 HP 55 A            8 HP 55 FL</p>
<p style="text-align: center;">E 15</p>  <p style="text-align: center;">13256</p>	<p>5p89.007.767            Setting master MAX            Measuring device front axle            manual with measuring bar</p>	<p>identical            8 HP 55 A            8 HP 55 FL</p>



Comment	Order No. / Purpose	ITEM
<p>identical</p> <p>8 HP 55 A 8 HP 55 FL</p>	<p>5p01.003.811 Measuring device axial clearance output</p>	<p>E 16</p>  <p>13260</p>
<p>identical</p> <p>8 HP 55 A 8 HP 55 FL</p>	<p>5p89.007.918 Setting master MIN axial clearance output</p>	<p>E 17</p>  <p>13258</p>
<p>identical</p> <p>8 HP 55 A 8 HP 55 FL</p>	<p>5p89.007.919 Setting master MAX axial clearance output</p>	<p>E 18</p>  <p>13259</p>

ITEM	Order No. / Purpose	Comment
<p data-bbox="411 421 480 454">E 19</p>  <p data-bbox="188 864 268 898">13331</p>	<p data-bbox="767 427 1201 499">5p01.003.652 Measuring device pinion position</p> <p data-bbox="767 539 1206 685">5p89.007.273 Setting master MIN measuring device pinion position and differential housing</p> <p data-bbox="767 725 1206 871">589.007.277 Setting master MAX measuring device pinion position and differential housing</p>	<p data-bbox="1262 427 1374 461">identical</p> <p data-bbox="1262 501 1414 535">6 HP 28 AF</p> <p data-bbox="1262 546 1294 568">--</p> <p data-bbox="1262 577 1398 611">8 HP 55 A</p> <p data-bbox="1262 613 1414 647">8 HP 55 FL</p>

Comment	Order No. / Purpose	ITEM
<p>identical</p> <p>8 HP 55 A 8 HP 55 FL 8 HP 70 8 HP 70 X 8 HP 90 8 HP 90 S 8 HP 90 A 8 HP 90 74 A</p>	<p>AA00.555.684 Support ring for dismantling Snap ring pot 1 (large pot)</p>	<p>D 1</p>  <p>13274</p>
<p>identical</p> <p>8 HP 55 A 8 HP 55 FL 8 HP 70 8 HP 70 X 8 HP 90 8 HP 90 A 8 HP 90 S 8 HP 90 74 A</p>	<p>AA00.558.211 Support ring for dismantling Snap ring pot 3 (small pot)</p>	<p>D 2</p>  <p>13275</p>
<p>identical</p> <p>8 HP</p>	<p>AA00.566.429 Dismantling device Pump from intermediate plate</p>	<p>D 3</p>  <p>13340</p>



ITEM	Order No. / Purpose	Comment
<p style="text-align: center;">D 4</p>  <p>13038</p>	<p>AA00.653.106 Dismantling device drive wheel</p>	<p>identical</p> <p>8 HP 55 A 8 HP 55 FL 8 HP 90 A 8 HP 90 A 74</p>
<p style="text-align: center;">D 5</p>  <p>13272</p>	<p>1x56.122.209 / 1x56.122.227 Dismantling device output sealing sleeve (Kukko standard removal tools 21/7 and 22/2)</p>	<p>universal</p>
<p style="text-align: center;">D 6</p>  <p>13334</p>	<p>5x46.003.826 Dismantling Small needle bearing front axle shaft  (Facom Gleithammer U49P7)</p>	<p>identical</p> <p>8 HP 55 A 8 HP 90 A 8 HP 90 A 74</p>



Comment	Order No. / Purpose	ITEM
<p>identical</p> <p>8 HP 55 A 8 HP 55 FL 8 HP 90 A 8 HP 90 A 74</p>	<p>5x46.485.481 Dismantling device for tapered roller bearing front axle shaft</p>	<p>D 7</p>  <p>13266</p>
<p>identical</p> <p>8 HP</p>	<p>5x46.003.682 Dismantling device Nail sleeve from guide wheel shaft</p>	<p>D 8</p>  <p>13338</p>
<p>identical</p> <p>8 HP 55 A 8 HP 55 FL 8 HP 90 A 8 HP 90 A 74</p>	<p>Dismantling device for tapered roller bearing</p> <p>5x46.010.011 Basic unit Differential (large/small bearing), Drive wheel (small bearing), Front axle shaft</p> <p>5x46.501.349 Rollex removal tool Drive wheel (small)</p>	<p>D 9</p>  <p>13339</p>

ITEM	Order No. / Purpose	Comment
<p style="text-align: center;">D 10</p>  <p>09117</p>	<p>AA00.549.851 Dismantling device Connection shaft Side shaft with press</p>	<p>identical 6 HP 28 AF -- 8 HP 55 A 8 HP 55 FL 8 HP 90 A 8 HP 90 A 74</p>
<p style="text-align: center;">D 11</p>  <p>13264</p>	<p>AA01.062.070 Dismantling device Shaft seal pinion shaft</p>	<p>identical 8 HP 55 A 8 HP 55 FL</p>
<p style="text-align: center;">D 12</p>  <p>13265</p>	<p>5x46.003.801 Dismantling device Pinion / Bearing (combination bearing) top bearing section</p>	<p>identical 6 HP 28 AF -- 8 HP 55 A 8 HP 55 FL</p>

Comment	Order No. / Purpose	ITEM
<p>identical</p> <p>6 HP 28 AF</p> <p>--</p> <p>8 HP 55 A</p> <p>8 HP 55 FL</p>	<p>5x46.802.048</p> <p>Dismantling device</p> <p>Pinion / Bearing</p> <p>(combination bearing)</p> <p>Bottom tapered roller bearing</p>	<p>D 13</p> <div data-bbox="890 477 1420 902" data-label="Image"> <p>13273</p> </div>
<p>identical</p> <p>6 HP 26</p> <p>--</p> <p>8 HP</p>	<p>5x46.001.210</p> <p>Sealing sleeve puller</p>	<p>D 14</p> <div data-bbox="890 1037 1420 1462" data-label="Image"> <p>10153</p> </div>
<p>identical</p> <p>8 HP</p>	<p>AA00.612.091</p> <p>Removal device for</p> <p>output flange</p> <p>Differential</p> <p>(centrifugal hammer)</p>	<p>D15</p> <div data-bbox="890 1597 1420 2022" data-label="Image"> <p>14022</p> </div>









ITEM	Order No. / Purpose	Comment
<p style="text-align: center;">D 16</p>  <p>14023</p>	<p>5x46.806.649 Dismantling device tapered roller bearing differential (large bearing)</p>	<p>identical 8 HP 55 A 8 HP 55 FL 8 HP 90 A 8 HP 90 A 74</p>
<p style="text-align: center;">D 17</p>  <p>14028</p>	<p>5x46.002.000 Dismantling device tapered roller bearing (large bearing) differential thrust piece, drive wheel</p>	<p>identical 8 HP 55 A 8 HP 55 FL 8 HP 90 A 8 HP 90 A 74</p>
<p style="text-align: center;">D 18</p>  <p>14027</p>	<p>5x46.000.165 Dismantling device tapered roller bearing front axle shaft thrust piece</p>	



Comment	Order No. / Purpose	ITEM
<p>identical</p> <p>8 HP 55 A 8 HP 55 FL 8 HP 90 A 8 HP 90 A 74</p>	<p>5x46.170.164 Dismantling device for tapered roller bearing (small bearing) differential thrust piece, drive wheel, output gear</p>	<p>D 19</p>  <p>14029</p>
<p>identical</p> <p>8 HP 55 A 8 HP 55 FL 8 HP 90 A 8 HP 90 A 74</p>	<p>Dismantling device tapered roller bearing</p> <p>5x46.503.491 Basic unit output gear, drive wheel (large bearing), differential (small bearing),</p> <p>5x46.032.010 Rollex removal tool drive wheel (large bearing) output gear</p>	<p>D 20</p>  <p>14030</p>
<p>identical</p> <p>8 HP 55 A 8 HP 55 FL 8 HP 90 A 8 HP 90 A 74</p>	<p>Dismantling device for tapered roller bearing</p> <p>5x46.010.011 Basic unit front axle shaft, differential (large/small bearing), drive wheel (small bearing)</p> <p>5x46.806.649 Rollex removal tool differential (large bearing)</p>	<p>D 21</p>  <p>14031</p>



ITEM	Order No. / Purpose	Comment
<p data-bbox="411 421 480 454">D 22</p>  <p data-bbox="188 864 272 898">14036</p>	<p data-bbox="767 427 1110 533">AA00.532.417 Dismantling device bearing shell drive wheel</p>	<p data-bbox="1262 427 1374 461">identical</p> <ul style="list-style-type: none"> <li data-bbox="1262 501 1398 535">8 HP 55 A</li> <li data-bbox="1262 539 1414 573">8 HP 55 FL</li> <li data-bbox="1262 577 1394 611">8 HP 90 S</li> <li data-bbox="1262 616 1398 649">8 HP 90 A</li> <li data-bbox="1262 654 1437 687">8 HP 90 A 74</li> </ul>

Comment	Order No. / Purpose	ITEM
<p>identical</p> <p>8 HP</p>	<p>AA00.686.190            Holding device            Dismantling / Assembly drive            shaft snap ring gearset 2</p>	<p>D M 1</p>  <p>13282</p>
<p>universal</p>	<p>AA01.072.185            Mandrel press</p> <p>5x66.000.075            Adapter for support plate            mandrel press</p>	<p>D M 2</p>  <p>14005</p>
<p>identical</p> <p>8 HP 55 A            8 HP 55 FL            8 HP 90 S            8 HP 90 A            8 HP 90 A 74</p>	<p>AA00.615.807            Dismantling / Assembly device            Guide sleeve mechatronic unit</p>	<p>D M 3</p>  <p>14010</p>



ITEM	Order No. / Purpose	Comment
<p data-bbox="405 421 488 454">DM 4</p>  <p data-bbox="188 864 268 898">14001</p>	<p data-bbox="767 427 1137 499">5t66.000.128 Dismantling / Assembly bar</p> <p data-bbox="775 539 1193 611"><i>(Index H required to be used for 8 HP)</i></p>	<p data-bbox="1262 427 1374 461">identical</p> <p data-bbox="1262 501 1430 607">8 HP 90 S 8 HP 90 A 8 HP 90 A74</p>
<p data-bbox="405 981 488 1014">DM 5</p>  <p data-bbox="188 1429 268 1462">13362</p>	<p data-bbox="767 987 999 1059">AA00.607.881 Assembly trolley</p>	
<p data-bbox="405 1541 488 1574">DM 6</p>  <p data-bbox="188 1989 268 2022">13276</p>	<p data-bbox="767 1552 1182 1697">AA00.604.766 Dismantling / Assembly device Rear axle flange (Distribution housing)</p>	<p data-bbox="1262 1552 1374 1585">identical</p> <p data-bbox="1262 1626 1398 1659">8 HP 55 A</p>



Comment	Order No. / Purpose	ITEM
<p>identical</p> <p>8 HP 45 X 8 HP 55 A 8 HP 55 FL 8 HP 90 A</p>	<p>5x46.001.856 Converter lifter (spigot Ø 23)</p>	<p>D M 7</p>  <p>13277</p>
<p>identical</p> <p>8 HP 55 A 8 HP 55 FL 8 HP 90 A 8 HP 90 A 74</p>	<p>AA00.356.002 Support dismantling vibration damper slot-in shaft output</p> <p>5p01.000.845 Dismantling / Assembly device ball bearings flanged shaft and vibration damper output shaft</p>	<p>D M 8</p>  <p>13225</p>
<p>Universal</p>	<p>AA00.549.448 Plastic mandrel (short)</p>	<p>D M 9</p>  <p>10169</p>



ITEM	Order No. / Purpose	Comment
<p data-bbox="395 421 496 454">D M 10</p>  <p data-bbox="188 864 268 898">13153</p>	<p data-bbox="767 427 1015 533">5x46.003.687 Mounting device Converter housing</p>	<p data-bbox="1262 427 1374 461">identical</p> <p data-bbox="1262 501 1414 535">6 HP 28 AF</p> <p data-bbox="1262 546 1289 568">--</p> <p data-bbox="1262 577 1398 611">8 HP 55 A</p> <p data-bbox="1262 616 1414 649">8 HP 55 FL</p> <p data-bbox="1262 654 1398 687">8 HP 90 A</p> <p data-bbox="1262 692 1437 725">8 HP 90 A 74</p>
<p data-bbox="395 981 496 1014">D M 11</p>  <p data-bbox="188 1429 268 1462">13278</p>	<p data-bbox="767 987 1046 1093">5p74.000.099 Mounting device intermediate housing</p>	<p data-bbox="1262 987 1477 1059">only suitable for 8 HP 55 A</p>
<p data-bbox="395 1541 496 1574">D M 12</p>  <p data-bbox="188 1984 268 2018">13279</p>	<p data-bbox="767 1547 959 1581">AA00.561.260</p> <p data-bbox="767 1626 1062 1731">AA00.561.262 Mounting device Pinion / Bearing / Nut</p>	<p data-bbox="1262 1547 1374 1581">identical</p> <p data-bbox="1262 1626 1414 1659">6 HP 28 AF</p> <p data-bbox="1262 1671 1289 1693">--</p> <p data-bbox="1262 1702 1398 1736">8 HP 55 A</p> <p data-bbox="1262 1740 1414 1774">8 HP 55 FL</p>

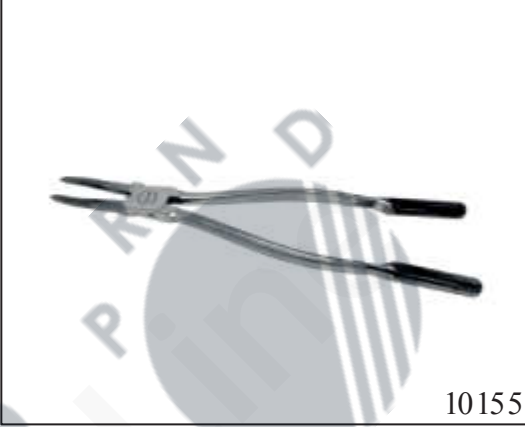

Comment	Order No. / Purpose	ITEM
<p>identical</p> <p>6 HP 28 AF -- 8 HP 55 A 8 HP 55 FL 8 HP 90 A 8 HP 90 A 74</p>	<p>AA00.561.169 Socket wrench pinion</p>	<p>D M 13</p>  <p>13280</p>
<p>identical</p> <p>8 HP 55 A 8 HP 55 FL 8 HP 90 A</p>	<p>AA00.564.638 Holding tool selector shaft (Electric gearshift)</p>	<p>D M 14</p>  <p>13143</p>
<p>identical</p> <p>8 HP</p>	<p>AA00.549.802 Lifting device Dismantling / Assembly oil supply</p> <p>AA00.359.399 Crank</p>	<p>D M 15</p>  <p>13097</p>



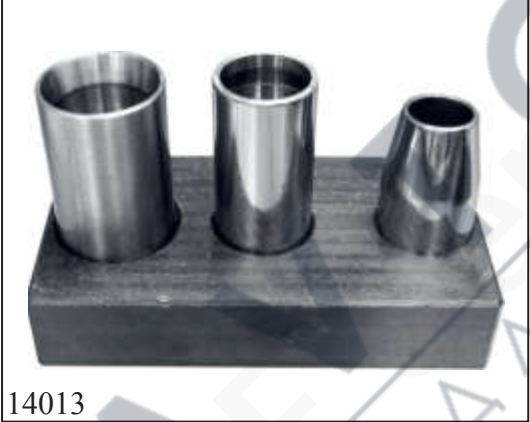



ITEM	Order No. / Purpose	Comment
<p data-bbox="395 421 497 454">D M 16</p>  <p data-bbox="188 864 268 898">13281</p>	<p data-bbox="767 427 1182 533">5x46.001.502 Dismantling / Assembly bar for disk spring clutch A</p>	<p data-bbox="1262 427 1374 533">identical 8 HP</p>
<p data-bbox="395 981 497 1014">D M 17</p>  <p data-bbox="188 1429 268 1462">10165</p>	<p data-bbox="767 987 1150 1093">5x46.003.957 Lifting device Dismantling / Assembly tower</p> <p data-bbox="767 1137 943 1205">5w46.000.003 Adapter</p>	<p data-bbox="1262 987 1374 1093">identical 8 HP</p>
<p data-bbox="395 1541 497 1574">D M 18</p>  <p data-bbox="188 1989 268 2022">10139</p>	<p data-bbox="767 1552 1150 1657">5x46.004.264 Supporting fixture Dismantling / Assembly tower</p>	<p data-bbox="1262 1552 1374 1657">identical 8 HP</p>

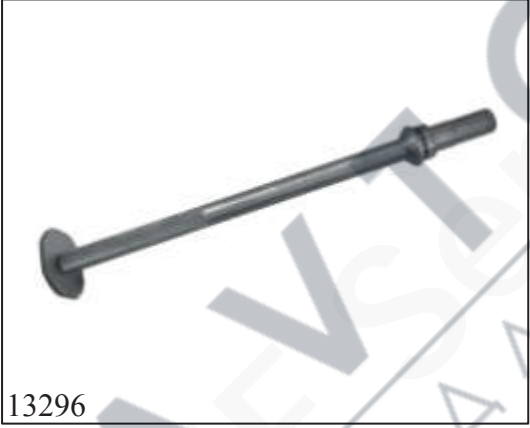

Comment	Order No. / Purpose	ITEM
universal	5x46.001.376 Pliers snap ring	DIM 19  10155
identical  8 HP 55 A 8 HP 55 FL 8 HP 70 8 HP 70 X 8 HP 90 8 HP 90 S 8 HP 90 A 8 HP 90 A 74	5x46.000.167 Dismantling / Assembly bar piston - clutch C	DIM 20  10167
identical  8 HP 55 A 8 HP 55 FL 8 HP 70 8 HP 70 X 8 HP 90 8 HP 90 S 8 HP 90 A 8 HP 90 A 74	AA00.349.340 Dismantling / Assembly bar for baffle plate - clutch D	DIM 21  14003



ITEM	Order No. / Purpose	Comment
<p style="text-align: center;">M 1</p>  <p>14006</p>	<p>5x46.003.843 Auxiliary tool for output gear and front axle shaft</p>	<p>identical 6 HP 28 AF -- 8 HP 55 A 8 HP 90 A 8 HP 90 A 74</p>
<p style="text-align: center;">M 2</p>  <p>14013</p>	<p>AA00.381.834 Assembly and centering device rectangular rings drive shaft</p>	<p>identical 8 HP</p>
<p style="text-align: center;">M 3</p>  <p>14020</p>	<p>AA00.549.949 Centering device rectangular rings drive shaft</p>	<p>identical 8 HP</p>

Comment	Order No. / Purpose	ITEM
<p>identical</p> <p>8 HP 55 A 8 HP 55 FL 8 HP 90 S 8 HP 90 A 8 HP 90 A 74</p>	<p>AA00.621.827 Assembly device for small tapered roller bearing on drive wheel</p>	<p>M 4</p>  <p>13316</p>
<p>identical</p> <p>8 HP 55 A 8 HP 55 FL 8 HP 90 A 8 HP 90 A 74</p>	<p>AA00.622.346 Assembly device for large tapered roller bearing on drive wheel</p>	<p>M 5</p>  <p>13318</p>
<p>identical</p> <p>8 HP 55 A 8 HP 90 A 8 HP 90 A 74</p>	<p>AA00.578.569 Press-in device bearing / output flange and WDR in distribution housing</p>	<p>M 6</p>  <p>13365</p>

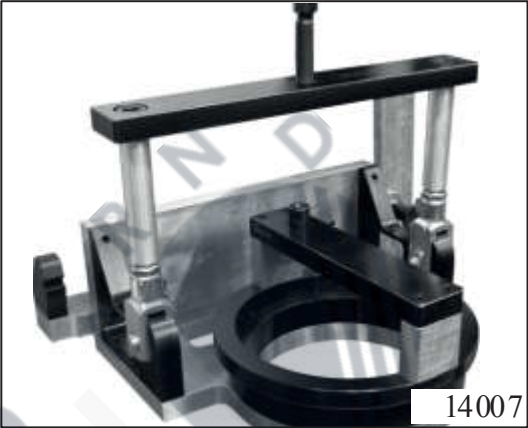

ITEM	Order No. / Purpose	Comment
<p data-bbox="419 421 475 450">M 7</p>  <p data-bbox="188 864 268 893">14038</p>	<p data-bbox="767 430 1166 533">AA00.574.045 Drive-in tool sealing sleeve Transmission housing, outside</p>	<p data-bbox="1262 430 1374 459">identical</p> <p data-bbox="1262 504 1437 683">8 HP 55 A 8 HP 55 FL 8 HP 90 S 8 HP 90 A 8 HP 90 A 74</p>
<p data-bbox="419 981 475 1010">M 8</p>  <p data-bbox="188 1429 268 1458">13296</p>	<p data-bbox="767 990 1150 1093">AA00.554.817 Drive-in tool sealing sleeve Transmission housing, inside</p>	<p data-bbox="1262 990 1374 1019">identical</p> <p data-bbox="1262 1064 1437 1243">8 HP 55 A 8 HP 55 FL 8 HP 90 S 8 HP 90 A 8 HP 90 A 74</p>
<p data-bbox="419 1541 475 1570">M 9</p>  <p data-bbox="188 1989 268 2018">10149</p>	<p data-bbox="767 1550 1118 1653">5x46.002.561 Drive-in mandrel shaft seal Selector shaft</p>	<p data-bbox="1262 1550 1374 1579">identical</p> <p data-bbox="1262 1624 1358 1727">6 HP 26 --- 8 HP</p>

Comment	Order No. / Purpose	ITEM
<p>identical</p> <p>8 HP 45 X 8 HP 55 A 8 HP 90 S 8 HP 90 A</p>	<p><i>Manual transmission only:</i></p> <p>AA00.600.175 Fixing device locking spring</p>	<p>M 10</p>  <p>02026</p>
<p>identical</p> <p>5 HP 6 HP 8 HP</p>	<p>5x46.001.368 Drive-in tool clamping sleeve</p>	<p>M 11</p>  <p>13285</p>
<p>identical</p> <p>8 HP</p>	<p>AA00.637.175 Assembly device round wire ring cylinders C + E</p>	<p>M 12</p>  <p>10158</p>



ITEM	Order No. / Purpose	Comment
<p data-bbox="411 421 480 450">M 13</p>  <p data-bbox="188 864 268 898">13127</p>	<p data-bbox="767 427 1114 533">AA00.548.688 Assembly pliers snap ring gearset 3 / pot 2 / pot 1</p>	<p data-bbox="1262 427 1374 456">identical</p> <p data-bbox="1262 501 1326 530">8 HP</p>
<p data-bbox="411 981 480 1010">M 14</p>  <p data-bbox="188 1426 268 1460">10157</p>	<p data-bbox="767 987 1126 1093">5x46.003.918 Assembly device snap ring gearset 2 on drive shaft</p>	<p data-bbox="1262 987 1374 1016">identical</p> <p data-bbox="1262 1061 1414 1167">8 HP 55 A 8 HP 55 FL 8 HP 70</p>
<p data-bbox="411 1541 480 1570">M 15</p>  <p data-bbox="188 1986 268 2020">10162</p>	<p data-bbox="767 1547 1126 1653">5x46.003.913 Press-in tool for pump into intermediate plate</p>	<p data-bbox="1262 1547 1374 1576">identical</p> <p data-bbox="1262 1621 1326 1650">8 HP</p>



Comment	Order No. / Purpose	ITEM
<p>identical</p> <p>8 HP</p>	<p>AA00.602.553 Clamping device screw connection pump + intermediate plate</p>	<p>M 16</p>  <p>14007</p>
<p>identical</p> <p>8 HP</p>	<p>AA00.615.414 Drive-in mandrel cylindrical pin in transmission housing (intermediate plate)</p>	<p>M 17</p>  <p>14004</p>
<p>identical</p> <p>8 HP</p>	<p>AA00.373.240 Plate for pressing off the clutches</p>	<p>M 18</p>  <p>13286</p>









ITEM	Order No. / Purpose	Comment
<p data-bbox="411 421 481 452">M 19</p>  <p data-bbox="188 864 268 896">13287</p>	<p data-bbox="767 427 1114 459"><i>Manual transmission only:</i></p> <p data-bbox="767 501 1187 607">AA00.603.510 Alignment device selected slide and position sensor</p>	<p data-bbox="1262 427 1374 459">identical</p> <p data-bbox="1262 501 1398 645">8 HP 45 X 8 HP 55 A 8 HP 90 S 8 HP 90 A</p>
<p data-bbox="411 981 481 1012">M 20</p>  <p data-bbox="188 1429 268 1460">13288</p>	<p data-bbox="767 987 1050 1059">5x46.001.521 Securing pins oil pan</p>	<p data-bbox="1262 987 1374 1019">identical</p> <p data-bbox="1262 1061 1326 1093">8 HP</p>
<p data-bbox="411 1541 481 1572">M 21</p>  <p data-bbox="188 1989 268 2020">13289</p>	<p data-bbox="767 1547 1114 1695">5x46.002.220 Press-on device tapered roller bearing on differential (large bearing)</p>	<p data-bbox="1262 1547 1374 1579">identical</p> <p data-bbox="1262 1621 1433 1765">8 HP 55 A 8 HP 55 FL 8 HP 90 A 8 HP 90 A 74</p>

Comment	Order No. / Purpose	ITEM
<p>identical</p> <p>8 HP 55 A 8 HP 55 FL 8 HP 90 A 8 HP 90 A 74</p>	<p>5x46.002.218 Press-on device tapered roller bearing on differential (small bearing)</p>	<p>M 22</p>  <p>14035</p>
<p>identical</p> <p>8 HP 55 A 8 HP 55 FL</p>	<p>AA00.679.163 Press-in device shaft sealing ring pinion shaft</p>	<p>M 23</p>  <p>14037</p>
<p>identical</p> <p>8 HP 55 A 8 HP 55 FL 8 HP 90 A 8 HP 90 A 74</p>	<p>5x46.004.262 Assembly mandrel shaft sealing ring differential flanged shaft in converter housing</p>	<p>M 24</p>  <p>13291</p>

ITEM	Order No. / Purpose	Comment
<p data-bbox="411 421 480 450">M 25</p>  <p data-bbox="188 864 268 893">13324</p>	<p data-bbox="767 427 1190 533">5x46.004.034 Press-in tool for seal hold-down device</p> <p data-bbox="767 685 1182 831">5x46.004.033 Assembly sleeve seal hold-down device on drive wheel</p>	<p data-bbox="1262 427 1374 456">identical</p> <p data-bbox="1262 501 1437 607">8 HP 55 A 8 HP 90 A 8 HP 90 A 74</p> <p data-bbox="1262 651 1437 797">8 HP 55 A 8 HP 55 FL 8 HP 90 A 8 HP 90 A 74</p>
<p data-bbox="411 981 480 1010">M 26</p>  <p data-bbox="188 1429 268 1458">13293</p>	<p data-bbox="767 987 1182 1133">AA00.578.639 Press-in device shaft sealing ring in differential cover</p>	<p data-bbox="1262 987 1374 1016">identical</p> <p data-bbox="1262 1061 1437 1279">6 HP 28 AF -- 8 HP 55 A 8 HP 55 FL 8 HP 90 A 8 HP 90 A 74</p>
<p data-bbox="411 1541 480 1570">M 27</p>  <p data-bbox="188 1989 268 2018">13294</p>	<p data-bbox="767 1547 1182 1659">5x46.002.627 Assembly device for half-moon ring, flanged shaft</p>	<p data-bbox="1262 1547 1374 1576">identical</p> <p data-bbox="1262 1621 1437 1771">8 HP 55 A 8 HP 55 FL 8 HP 90 A 8 HP 90 A 74</p>

Comment	Order No. / Purpose	ITEM
	5x46.003.018 Drive-in mandrel for vent pipe	M 28  13295
identical  8 HP	AA00.613.946 Assembly mandrel shaft sealing ring and needle bearing in centering plate	M 29  10163
identical  8 HP 55 A 8 HP 55 FL 8 HP 90 A 8 HP 90 A 74	AA00.600.587 Press-in device bearing shells in front axle housing	M 30  13335

ITEM	Order No. / Purpose	Comment
<p style="text-align: center;">M 31</p>  <p>13337</p>	<p>AA00.625.669 Drive-in device bearing shell, drive wheel in transmission housing</p>	<p>identical</p> <p>8 HP 55 A 8 HP 55 FL 8 HP 90 A 8 HP 90 A 74</p>
<p style="text-align: center;">M 32</p>  <p>13313</p>	<p>5x46.003.834 Drive-in device bearing shell, front axle in transmission housing</p>	<p>identical</p> <p>8 HP 55 A 8 HP 55 FL 8 HP 90 A 8 HP 90 A 74</p>
<p style="text-align: center;">M 33</p>  <p>13341</p>	<p>5x46.003.738 Press-on device bearing and disk on side shaft</p>	<p>identical</p> <p>6 HP 28 AF -- 8 HP 55 A 8 HP 55 FL 8 HP 90 A 8 HP 90 A 74</p>

Comment	Order No. / Purpose	ITEM
<p>identical</p> <p>6 HP 28 AF -- 8 HP 55 A 8 HP 55</p>	<p>5x46.003.711 Press-in device needle sleeve 1 + 2 and tapered roller bearing on output gear</p>	<p>M 34</p>  <p>13336</p>
<p>identical</p> <p>6 HP 28 AF -- 8 HP 55 A 8 HP 90 A 8 HP 90 A 74</p>	<p>AA00.600.703 Assembly device needle sleeve on front axle shaft</p>	<p>M 35</p>  <p>13364</p>
<p>identical</p> <p>8 HP 55 A 8 HP 55 FL</p>	<p>AA00.596.017 counter support transmission housing</p>	<p>M 36</p>  <p>14048</p>









1.8.4 DIN schematic E26/17

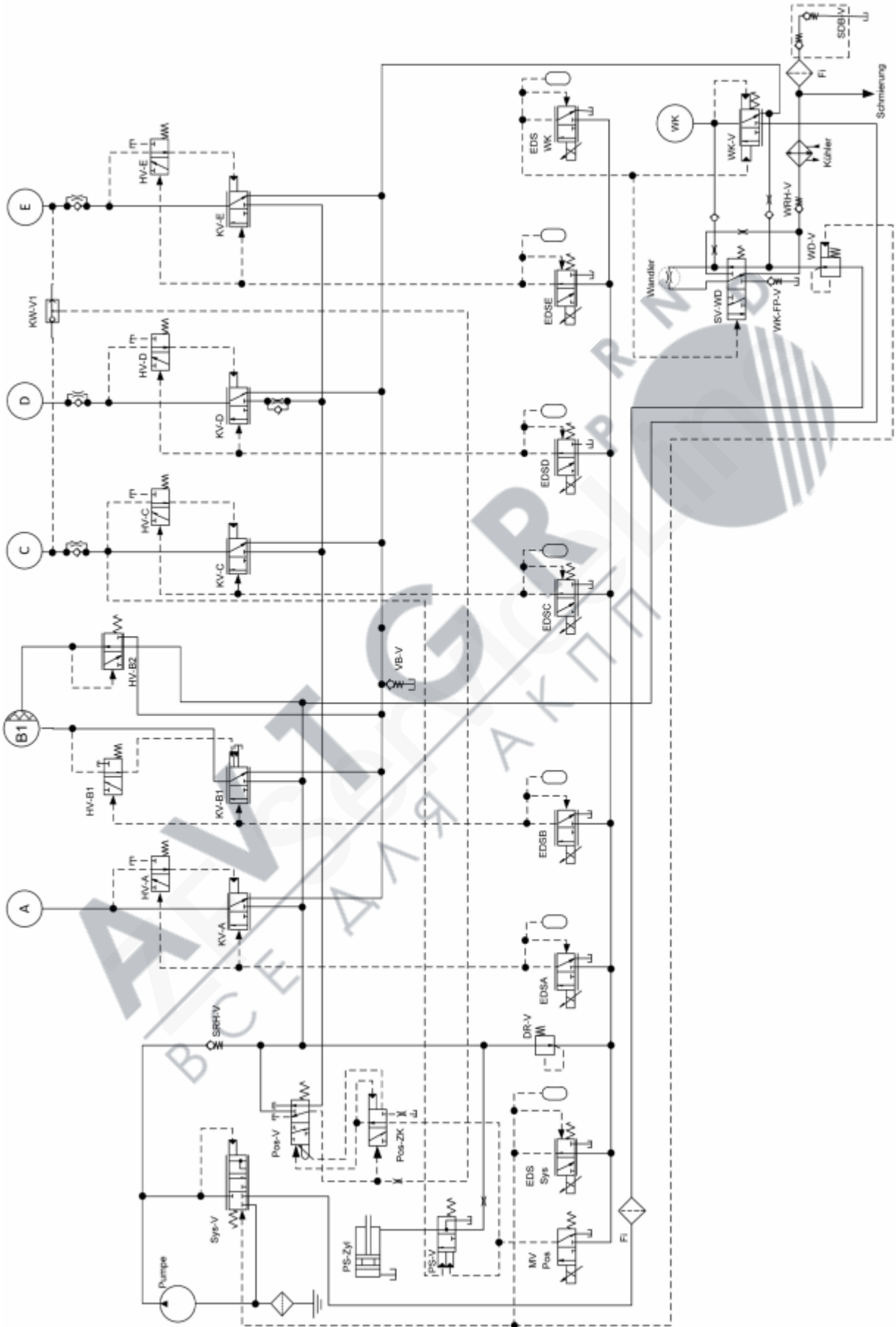

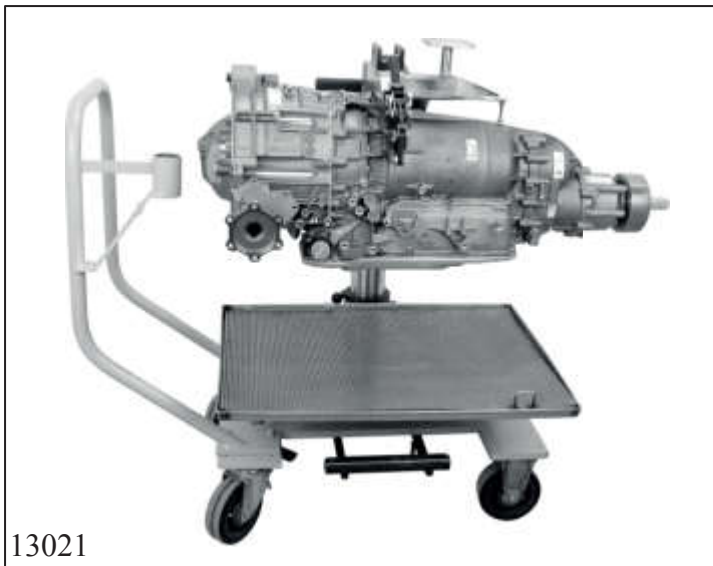

## 2. Dismantling

### 2.1 Preparations

#### 2.1.1 Drain transmission oil

Attach transmission in assembly bar 5t66.000.128 to assembly trolley AA00.607.881.

The oil pan must be facing downwards.

*The transmission has 3 oil systems.*

Drain residual oil:

1. Unscrew oil drain and oil filler screws from oil pan and transmission housing.
2. Unscrew front differential oil drain and oil filler plugs from converter housing and differential cover.
3. Unscrew front differential oil drain and oil filler plugs from converter housing and differential cover.



## 2.2 Transmission clearance and front axle output

### 2.2.1 Remove and dismantle distribution housing

Turn transmission with converter side at bottom.

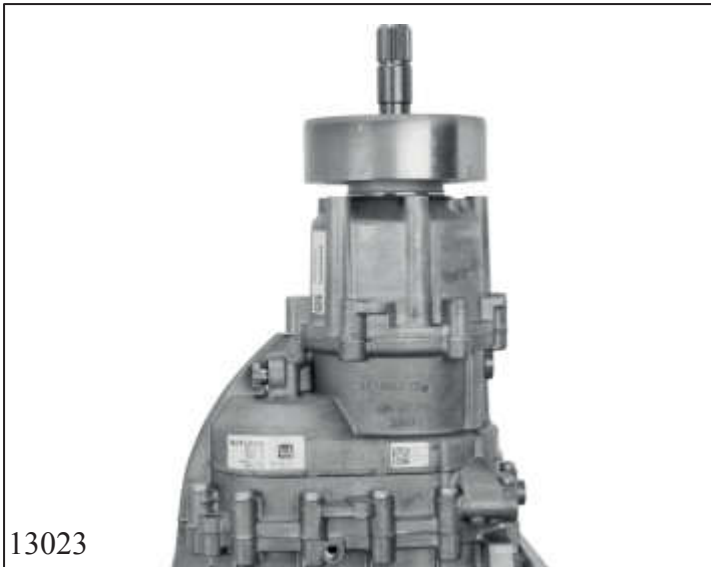

Remove 6 screws from distribution housing.

Remove distribution housing.

Remove torsen differential upwards.

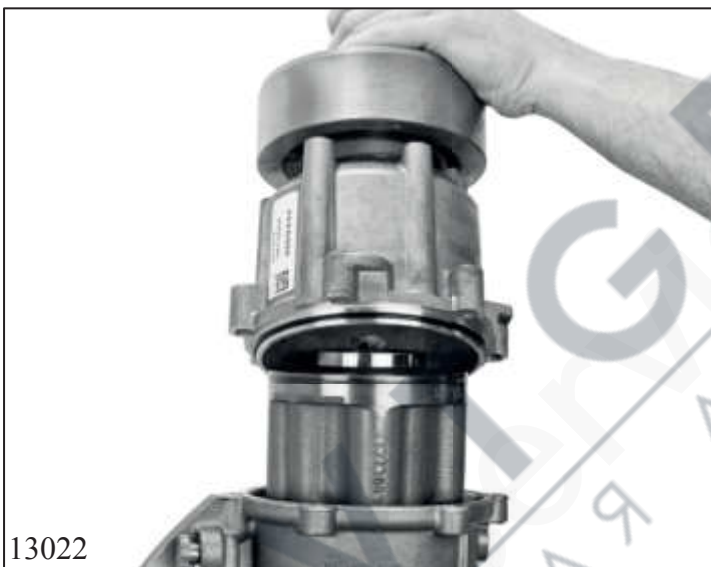

Insert distribution housing into device 5p01.000.845.

Position support AA00.356.002 between distribution housing and vibration damper.

Pull O-ring off distribution housing.



Remove small snap ring from slot-in shaft.

Press out slot-in shaft using mandrel press.

Take distribution housing out of device.

Remove shaft sealing ring with suitable tools.

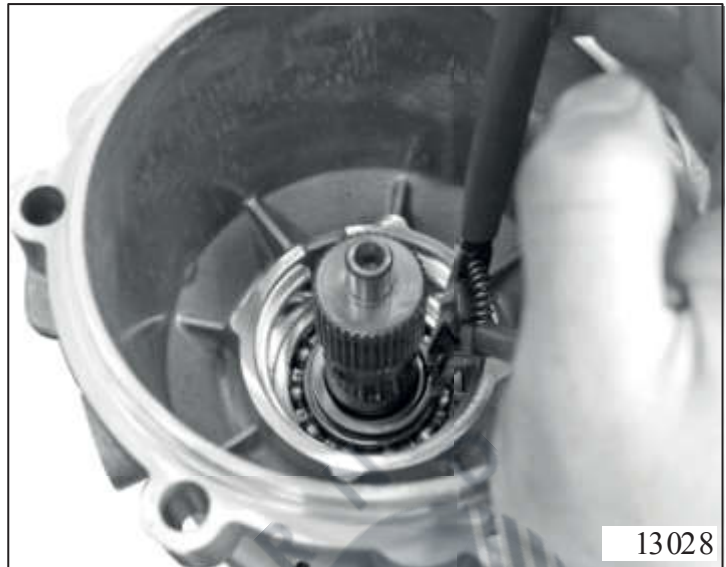

*Transmission with bending vibration damper*

Undo 3 screws on vibration damper and lift up vibration damper.

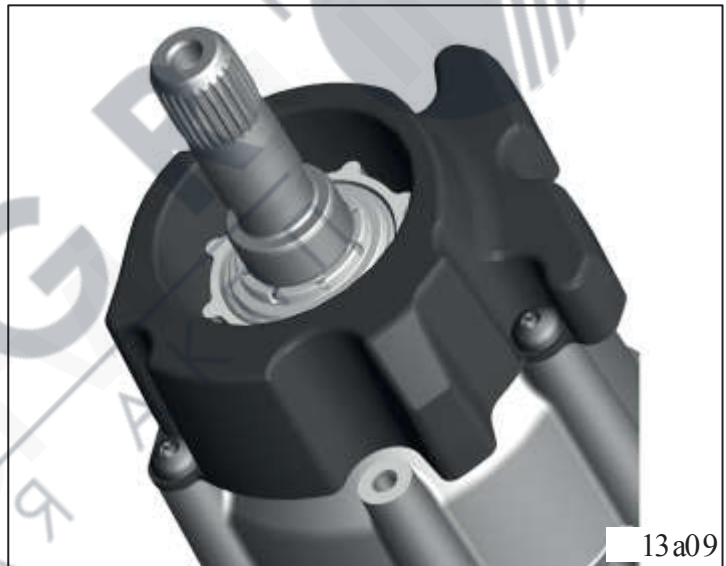

*Transmission with spray ring*

Remove spray ring with mandrel press.



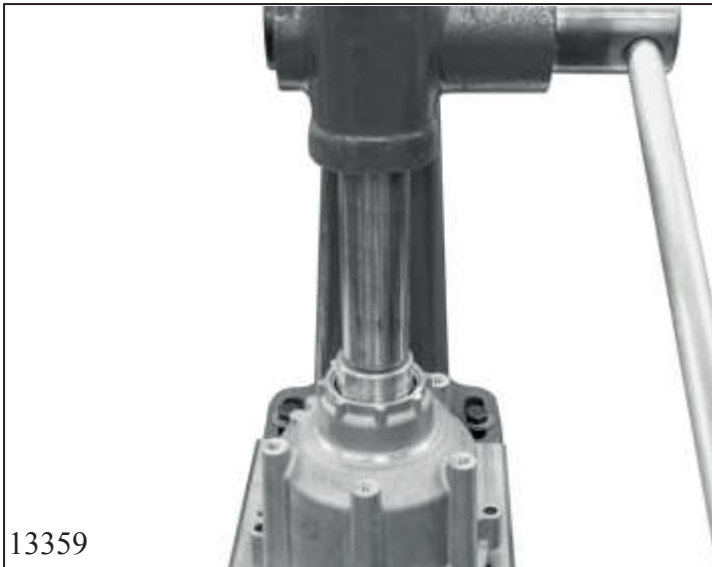

Remove large snap ring for ball bearing from distribution housing.

Press out ball bearing using suitable tools using mandrel press.

### 2.2.2 Remove intermediate housing and dismantle front axle output

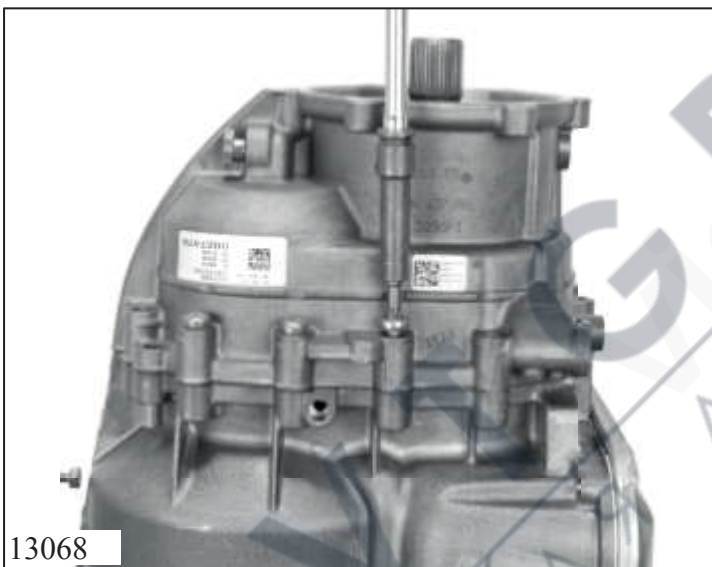

Remove 15 screws from intermediate housing.

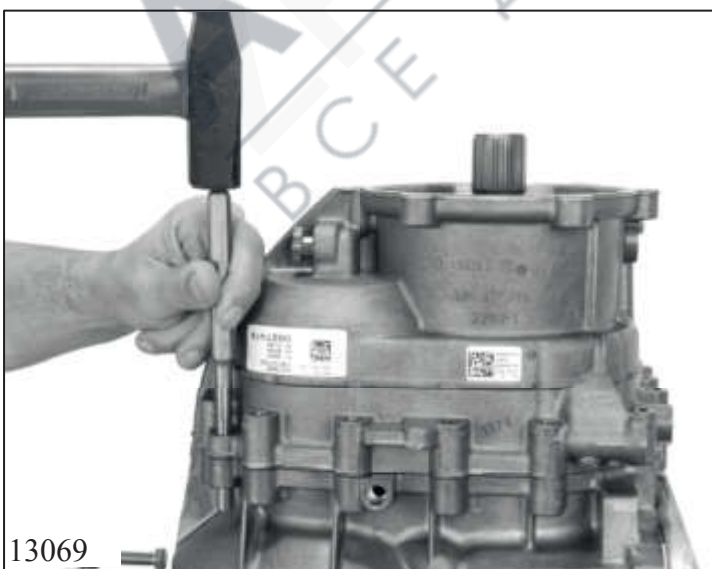

Drive both clamping sleeves approx. 10 mm towards transmission housing with a drive-in mandrel.

Remove intermediate housing.

Remove seal and magnet.

**NOTICE**

If the needle bearing is damaged the complete oil pump must be replaced.

Remove 4 screws from oil pump.

Remove oil pump and pump annulus from intermediate housing.

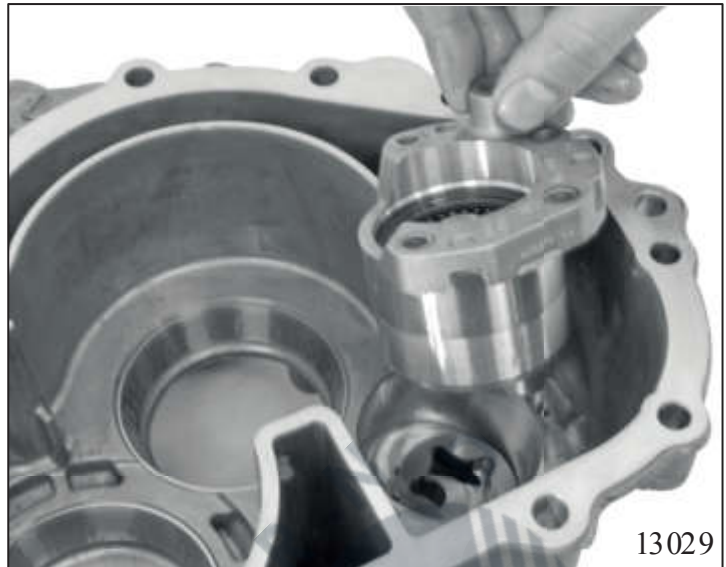

Remove output gear.

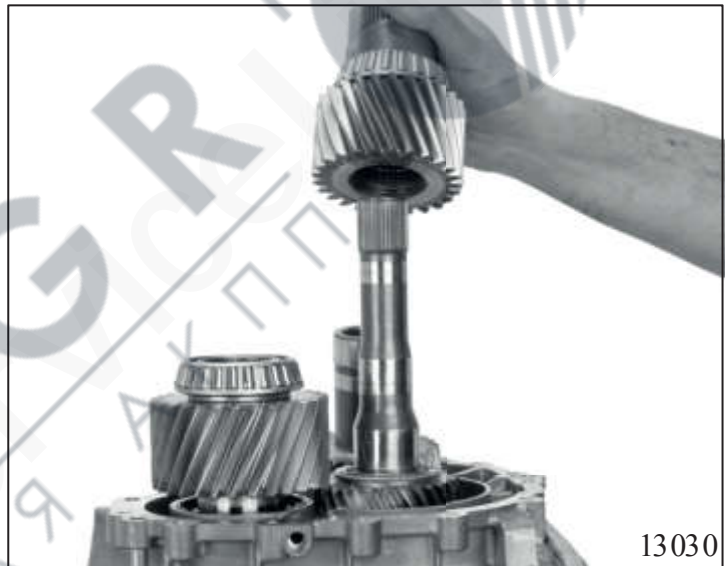

Undo screw in drive wheel and remove it.

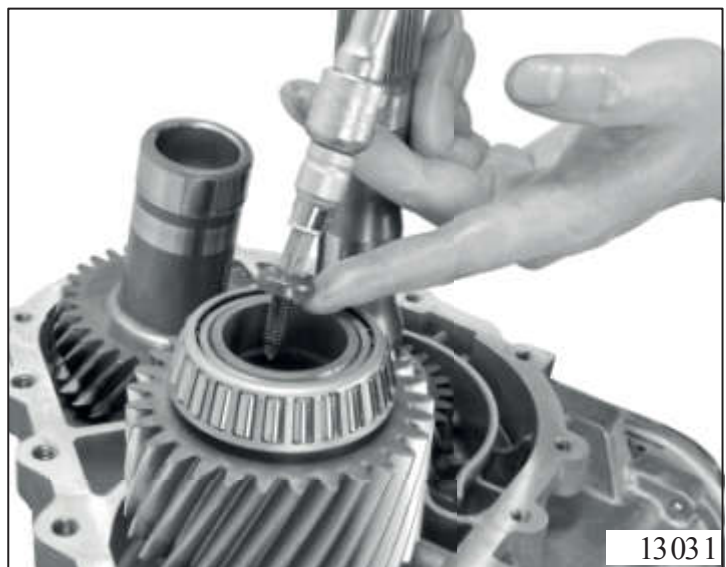





Release drive wheel using tool AA00.653.106.

Remove tool and drive wheel.

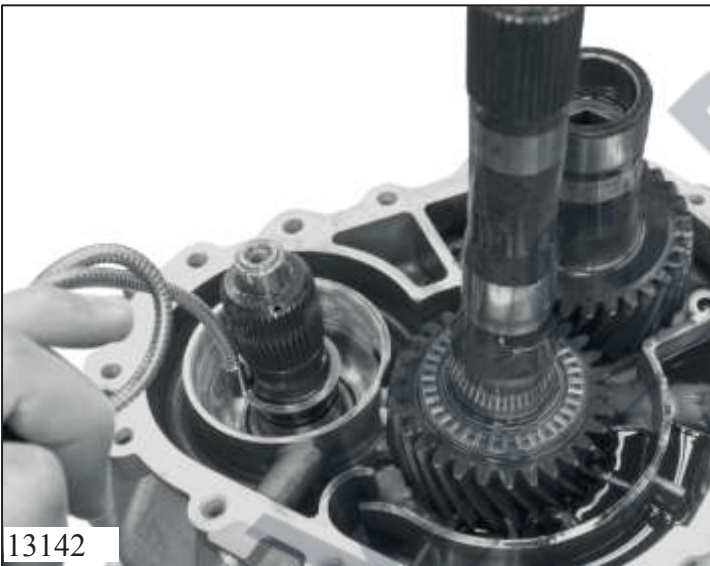

Remove transmission clearance shim with magnet.

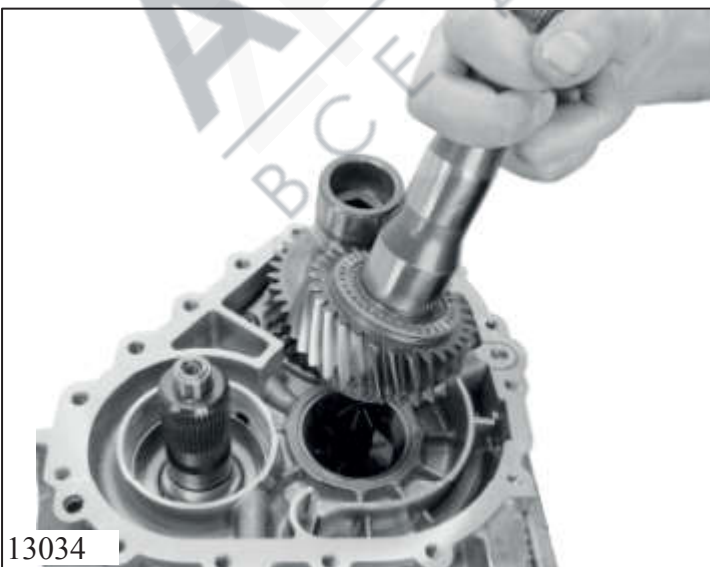

Remove front axle shaft.

Remove 2 screws from pinion shaft retaining plate.

Remove pinion with side shaft.

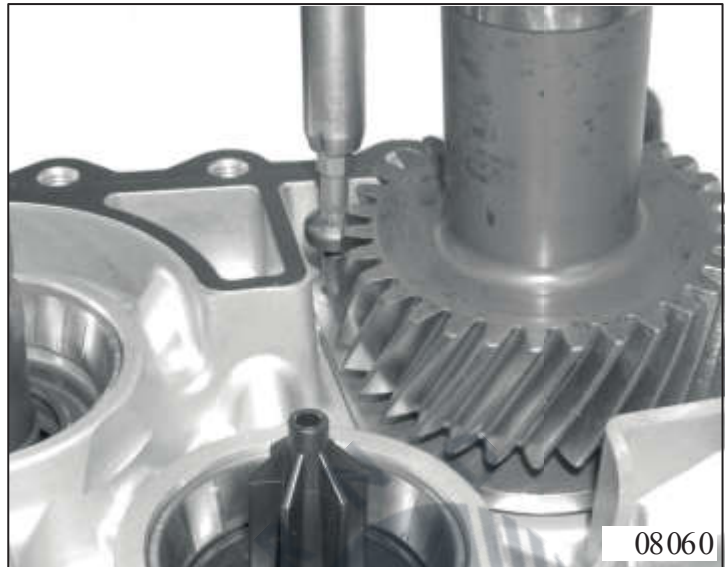

**NOTICE**

The oil distributor will be destroyed when it is removed.

Pull out oil distributor on rear of transmission housing with pliers.

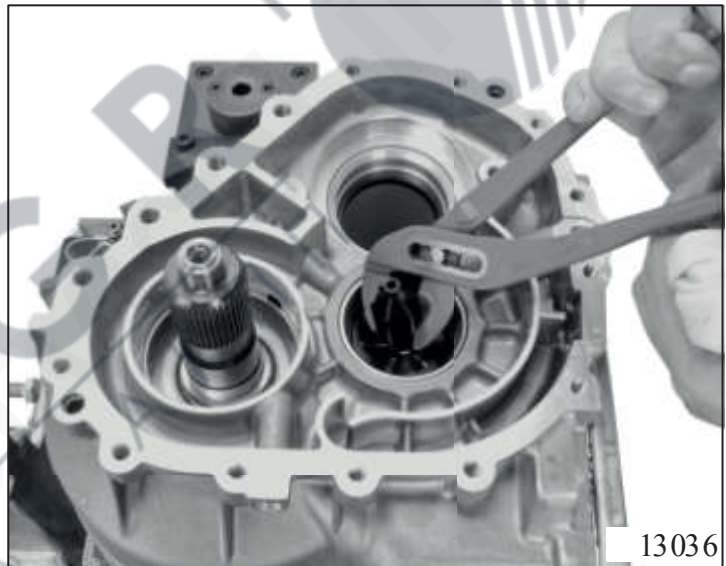

Place tool AA00.532.417 on drive shaft.

Pull off bearing shell using tool.

Remove shim.

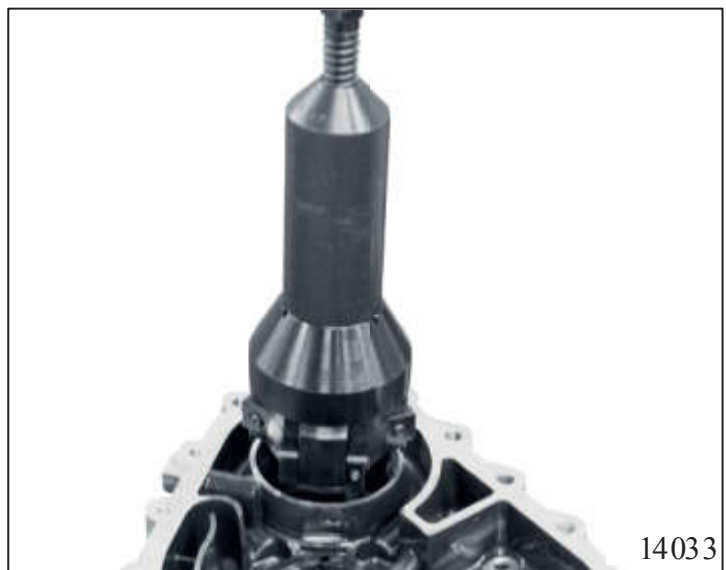



Place plastic panel on transmission housing for protection.

Pull out FA shaft bearing shell with tool 1X56.122.209/1X56.122.227.

### 2.2.3 Dismantle front axle shaft



Remove the needle bearing with thrust washer from front axle shaft.



Pull small needle sleeve out of front axle shaft using a suitable tool, for example 5x46.003.826 (Facom U.49P3 10-13 mm).

Place washer 5x46.000.165 on borehole in front axle shaft.



Position a suitable tool, for example 5x46.485.481 (Kukko puller) over washer on front axle shaft.

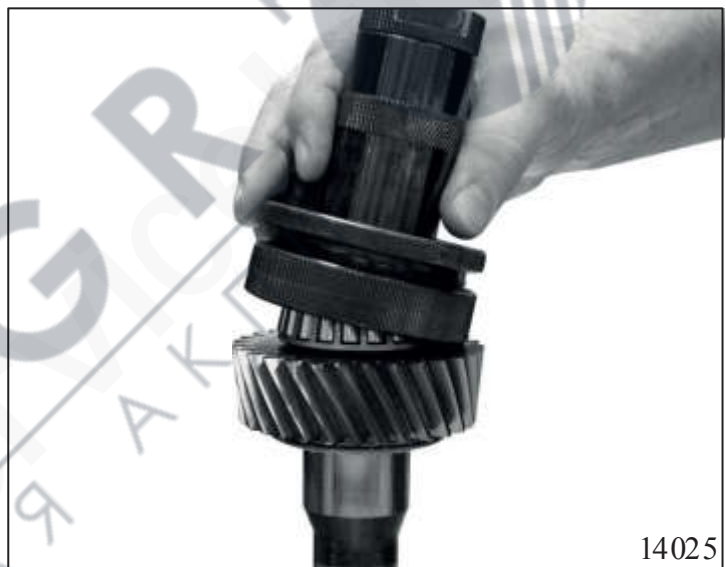

Pull tapered roller bearing off front axle shaft with tool.



## 2.2.4 Dismantle output gear

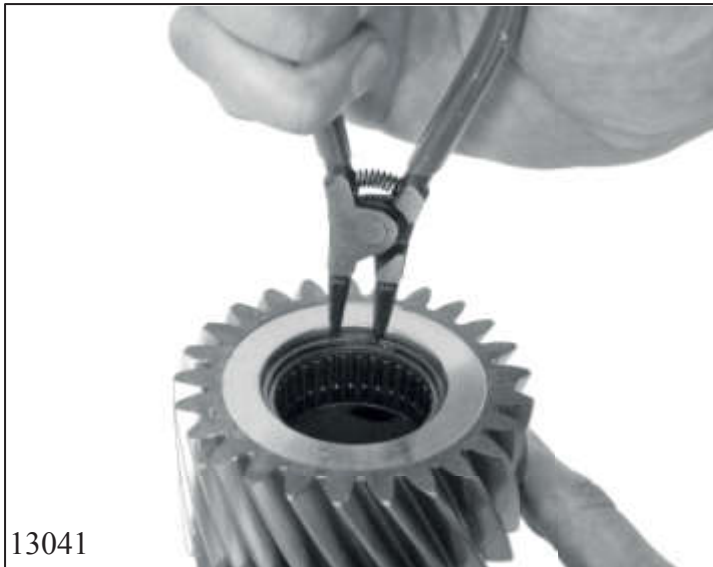

Using a suitable tool lever out snap ring in output gear at notch and remove it.



Pull large needle sleeve out of output gear using a suitable tool (for example Facom U.49P3 38-50 mm).

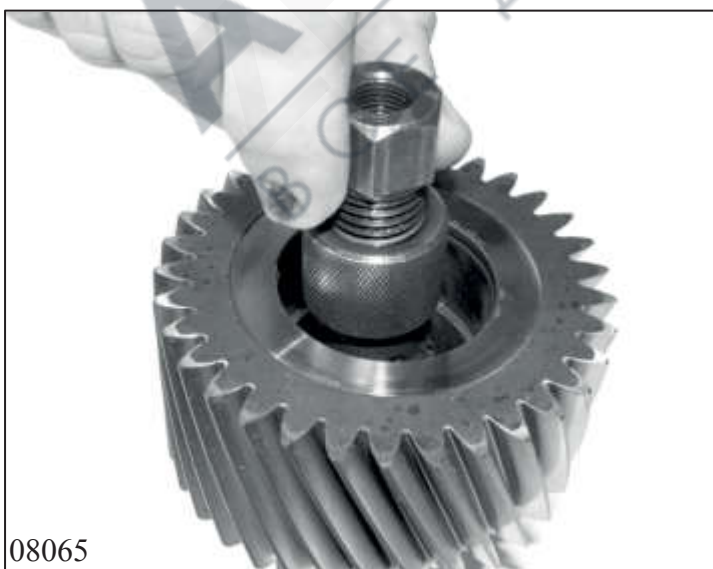

Pull small needle sleeve out of output gear using a suitable tool, for example 5x46.003.682 (Facom U.49P3 30-38 mm).

Cover borehole in output gear with a washer 5x46.002.000.

Pull tapered roller bearing off output gear using a suitable tool, for example basic unit 5x46.010.011 and Rollex puller 5x46.501.349.



### 2.2.5 Dismantle drive wheel

Lever disk spring out of drive wheel using a suitable tool.



Cover borehole in drive wheel with a washer 5x46.170.164.

Pull small tapered roller bearing off drive wheel using a suitable tool, for example basic unit 5x46.010.011 and Rollex puller 5x46.501.349.

Remove shaft sealing ring.

Turn drive wheel over.





08068

Cover borehole in drive wheel with a washer 5x46.002.000.

Pull large tapered roller bearing off drive wheel using a suitable tool, for example basic unit 5x46.503.491 and Rollex puller 5x46.032.010.

### 2.2.6 Dismantle side shaft



08068

Remove snap ring from side shaft ball bearing.

Insert side shaft into dismantling device AA00.549.851.

Press side shaft out of the sleeve using the mandrel.



08069

Press out bearing and retaining plate using a suitable tool using mandrel press.





## 2.3 Remove flanged shaft, front axle differential and converter

### 2.3.1 Remove flanged shaft and front axle differential

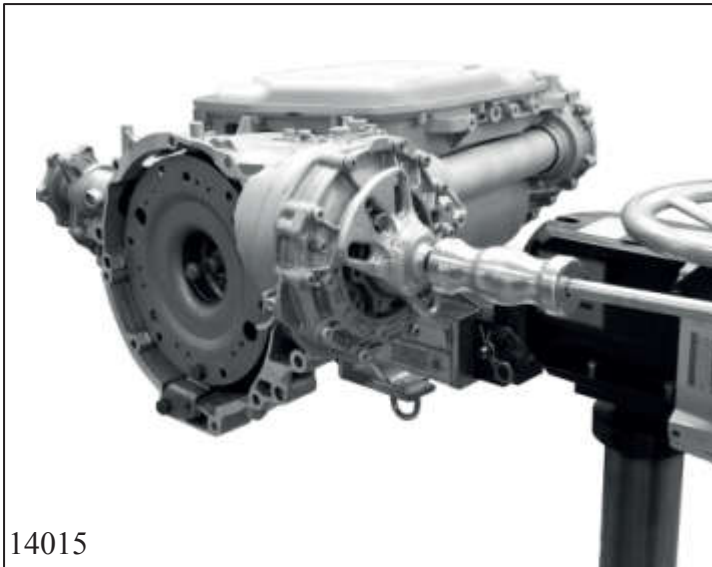

Lever out flange using tool AA00.612.091 or a suitable tool.

Lever locking ring out of flange using a screwdriver.

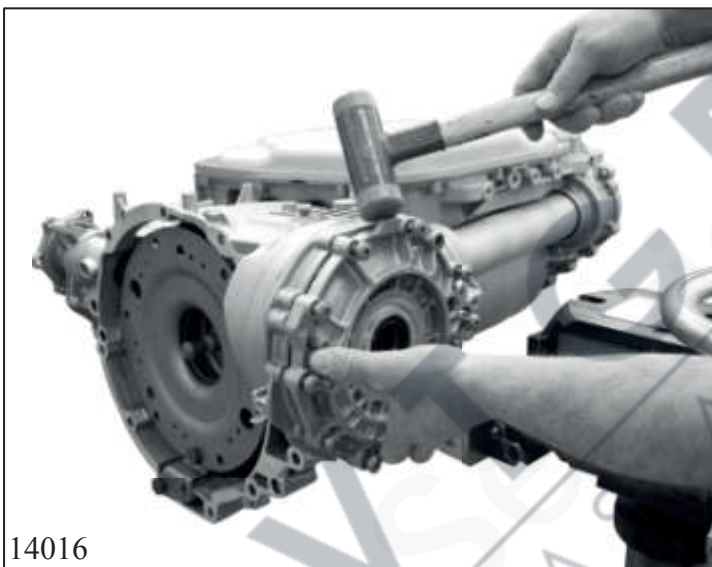

Remove 11 screws from differential cover.

Carefully release differential cover from converter housing with a plastic mallet and remove it.

Remove crown gear.

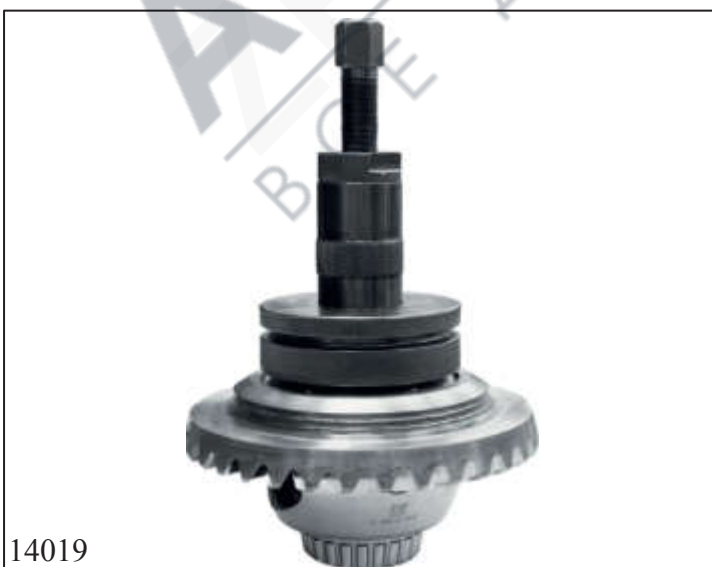

Place thrust piece 5x46.002.000 on crown gear borehole.

Position tool 5x46.806.649 on crown gear and pull off large tapered roller bearing.

Turn over crown gear.

Place thrust piece 5x46.170.164 on crown gear borehole.

Position tool 5x46.503.491 on crown gear and pull off small tapered roller bearing.

Pull O-ring off differential cover.

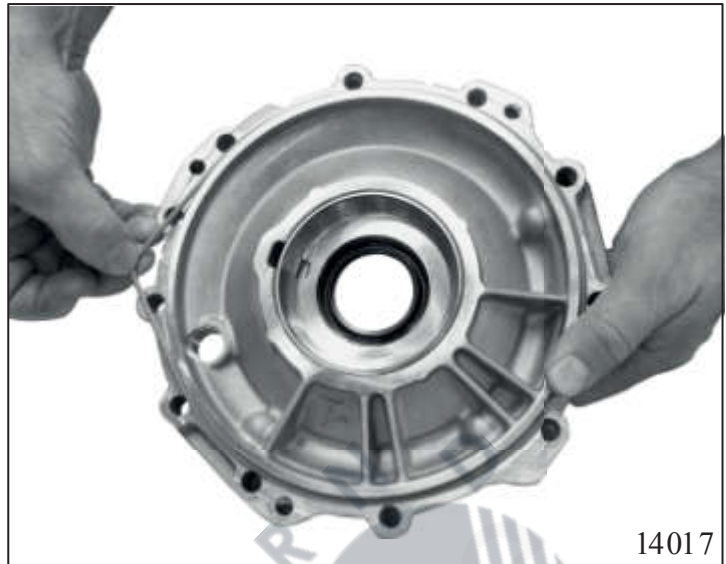

Remove bearing shell and shim from differential cover.

Drive shaft sealing ring out of differential cover using a suitable tool.

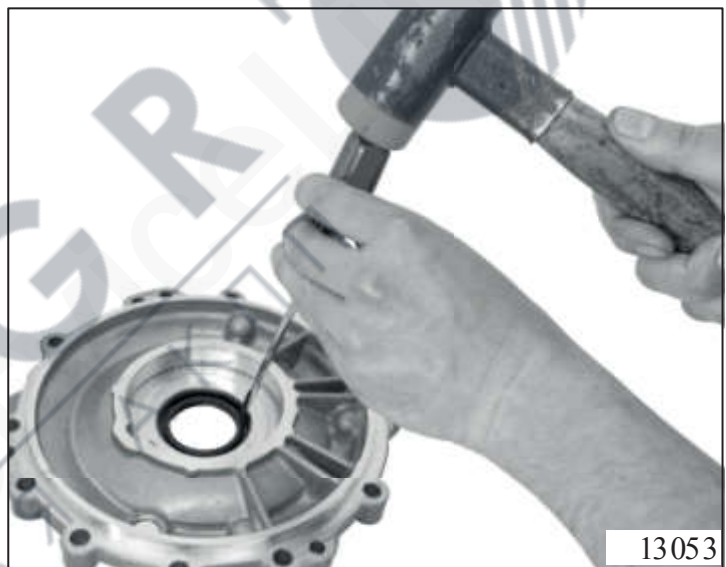

Remove bearing shell and shim from converter housing.

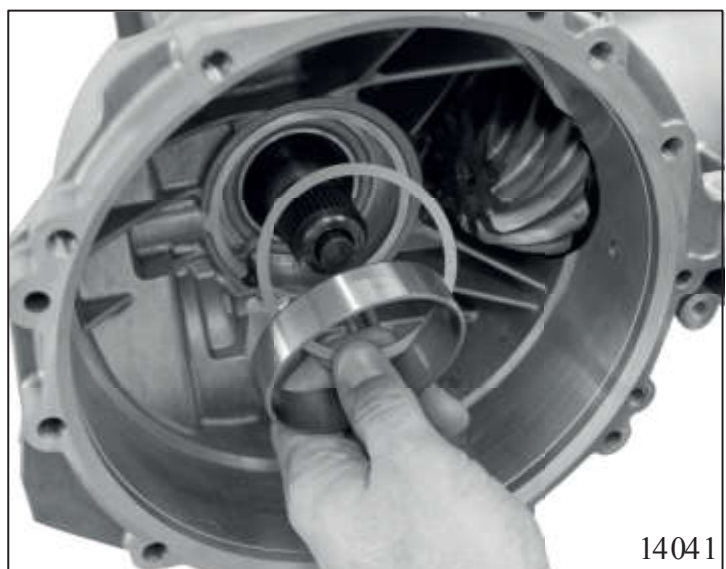

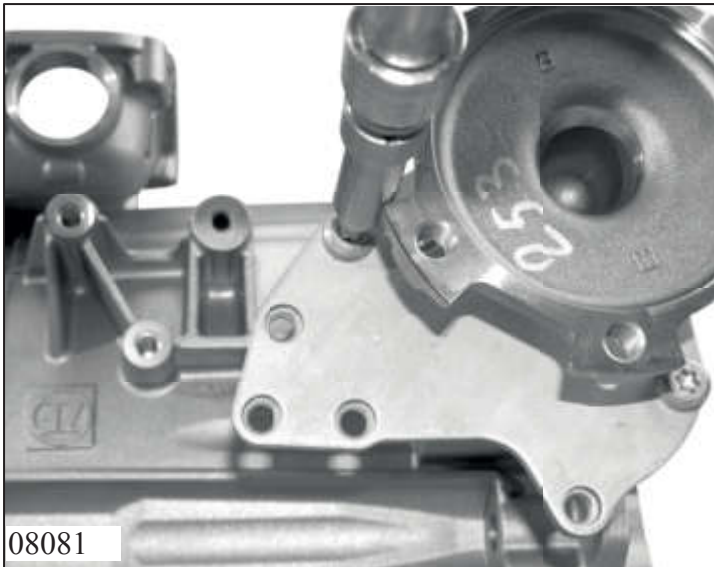

Remove 3 screws from flanged shaft hold-down device.

Remove the flanged shaft and hold-down device from transmission housing.

### 2.3.2 Dismantle flanged shaft



Remove springs and tappets from flanged shaft using a suitable tool.



Remove locking ring from flanged shaft.

Press bearing and hold-down device with support AA00.356.002 off flanged shaft using mandrel press.

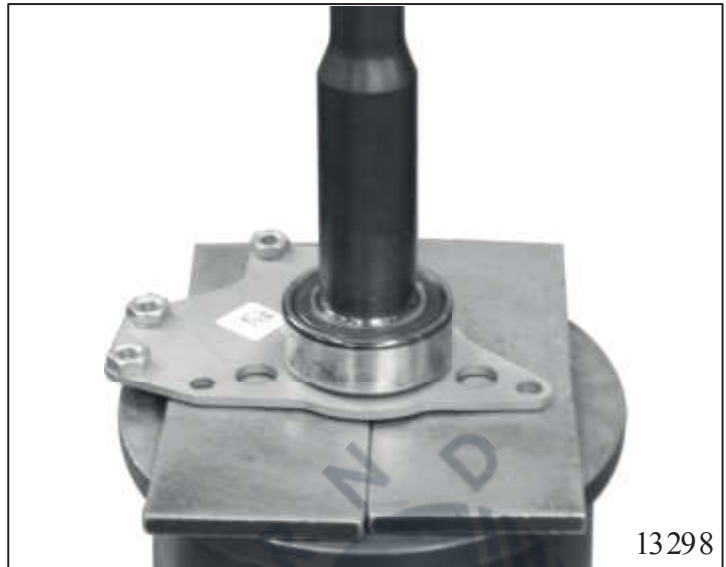

### 2.3.3 Remove converter

Unscrew hexagon screw with nut (M12x70) and hexagon screw (M12x16) from converter retaining bar.

Remove converter retaining bar.

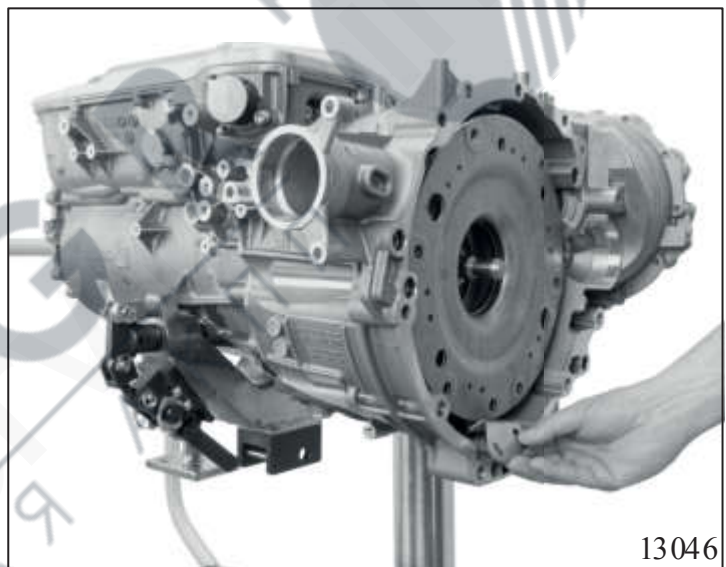

#### **WARNING**

**RISK OF ACCIDENT!** The lifting and moving of heavy parts without lifting equipment can lead to damage to health and severe injuries.

⇒ Use a crane or similar lifting equipment.

Remove converter with converter lifter 5x46.001.856.

Pull O-ring off drive shaft.



### 2.3.4 Remove converter housing

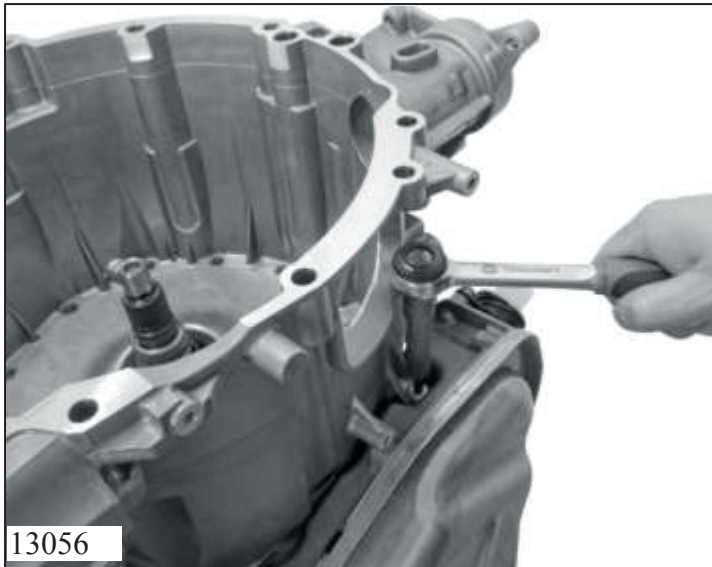

Turn transmission with converter side at the top.

Undo 1 screw outside and 14 screws inside converter housing.

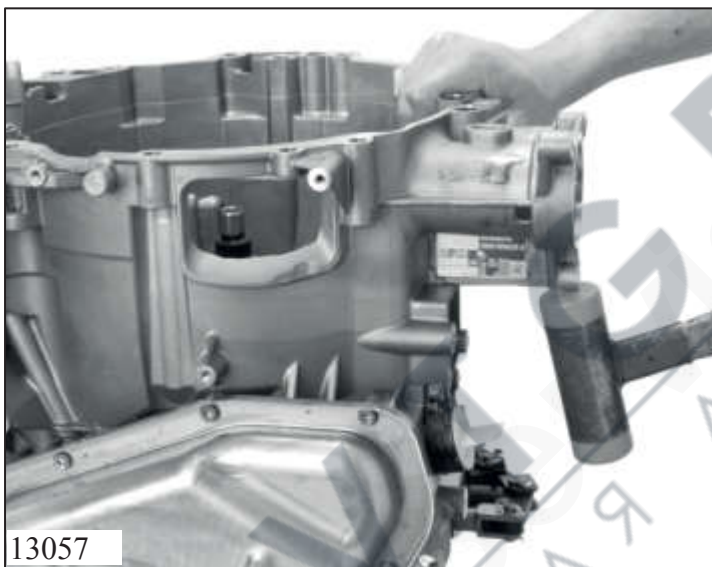

Release converter housing from transmission housing using a plastic mallet and remove it.

Remove seal.

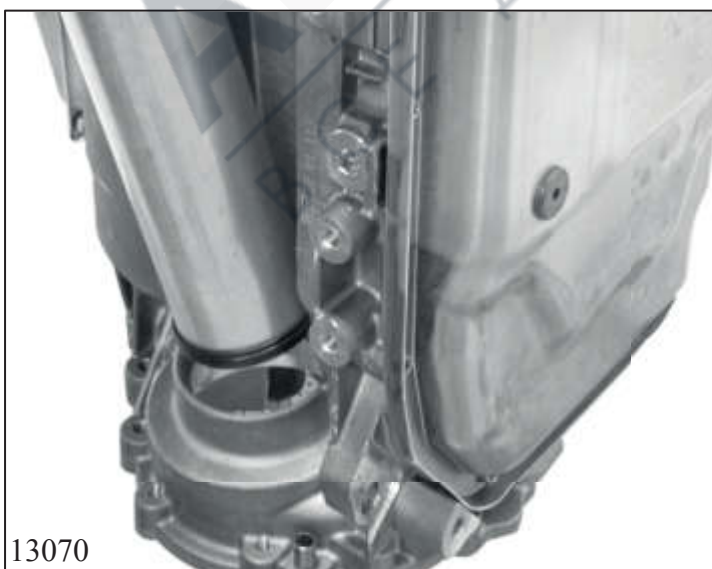

Pull protective tube with sealing ring out of transmission housing.

Pull sealing ring off protective tube.

Lever sealing ring off transmission housing using a suitable tool.

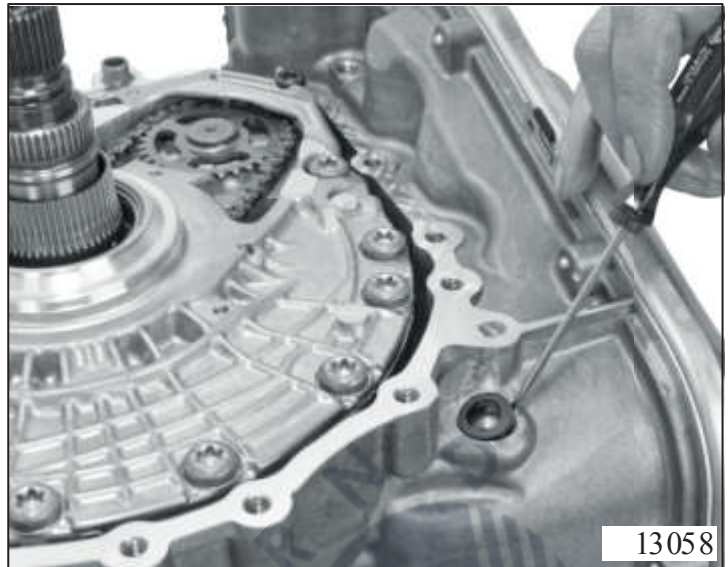

### 2.3.5 Dismantle converter housing

Fit and secure holding device 5x46.003.687 on assembly trolley or workbench.

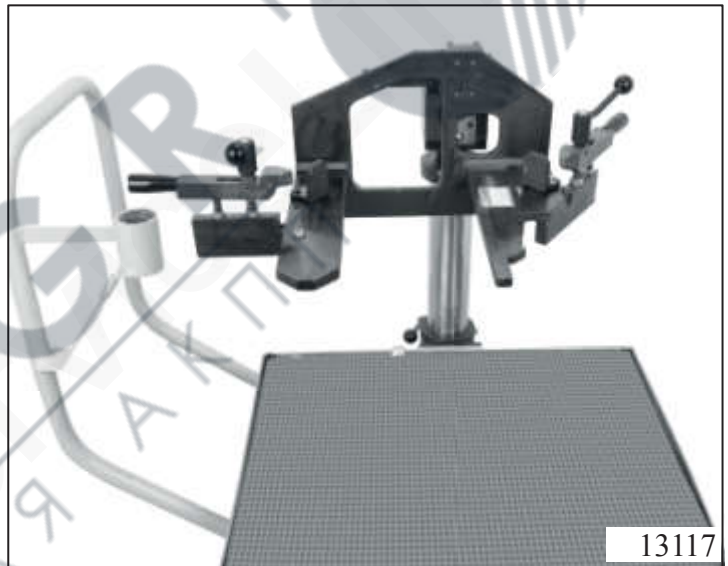

Position converter housing in both adjusting pins.



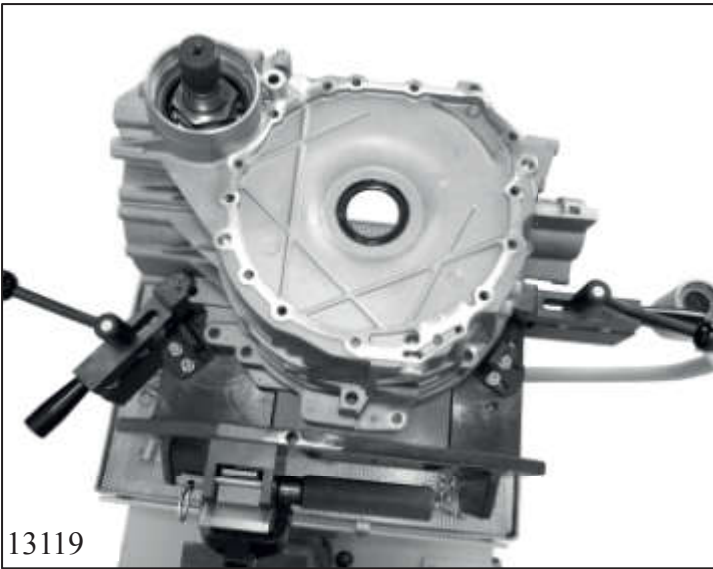

Position two clamping elements and clamp converter housing.

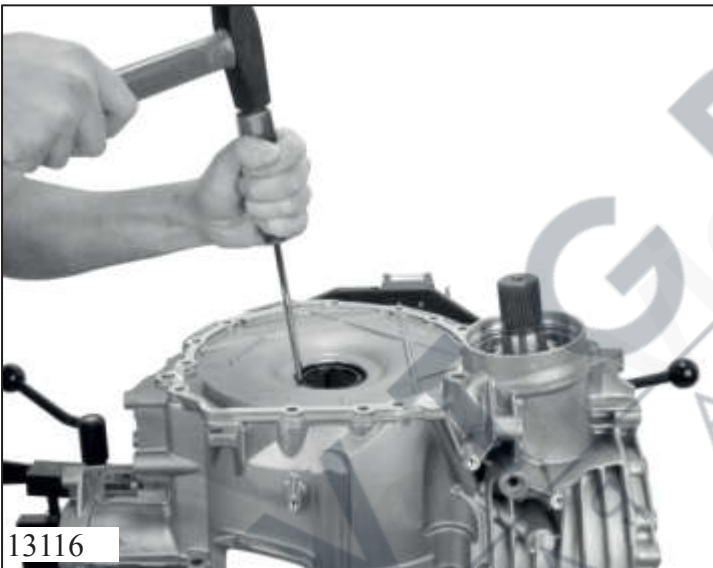

Remove drive shaft sealing ring.

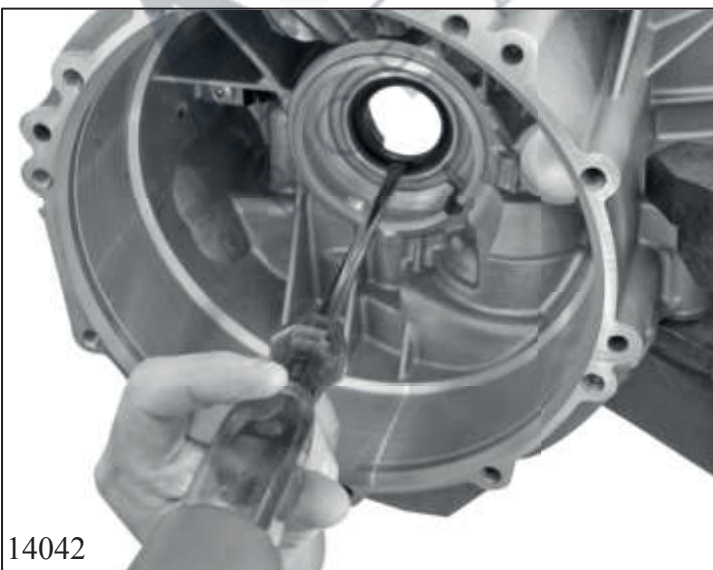

Drive out flanged shaft sealing ring in converter housing using tool.

Undo retaining plate screw from converter housing.

Remove retaining plate and magnet.

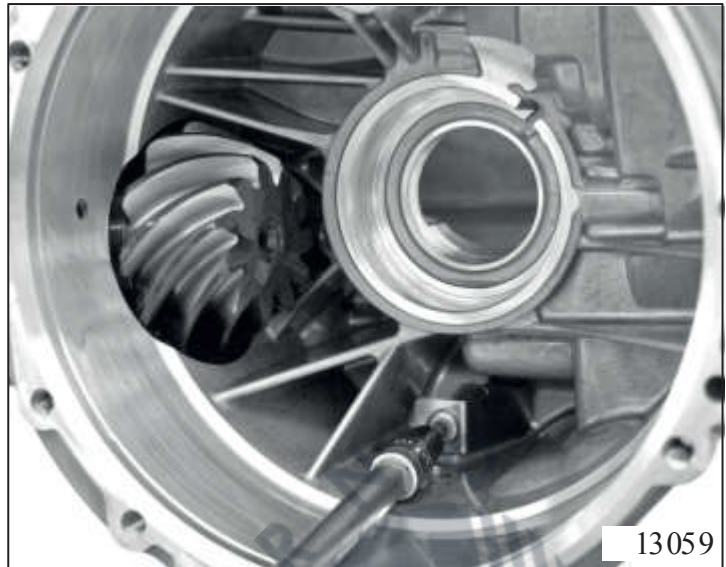

Push two bolts on tool AA01.062.070 through two marks on shaft sealing ring (side shaft) and turn them through 90°.

Lock both bolts with puller and pull out shaft sealing ring by turning spindle.

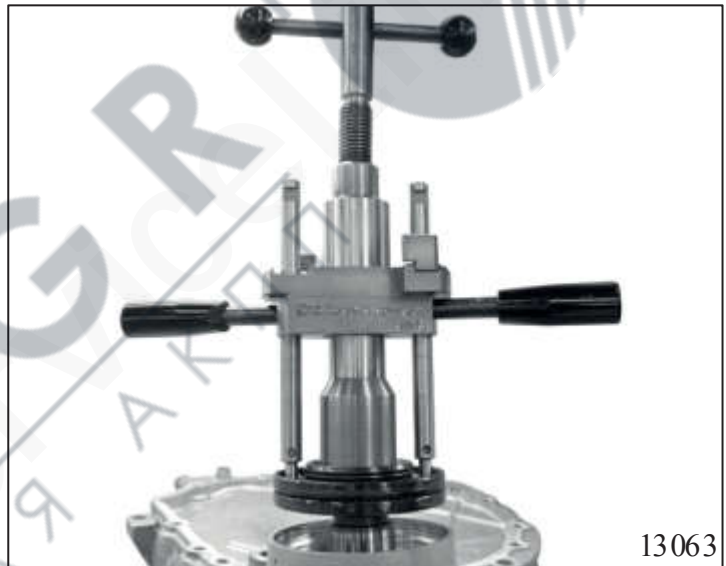

### 2.3.6 Remove pinion shaft

Remove locking ring from pinion shaft.

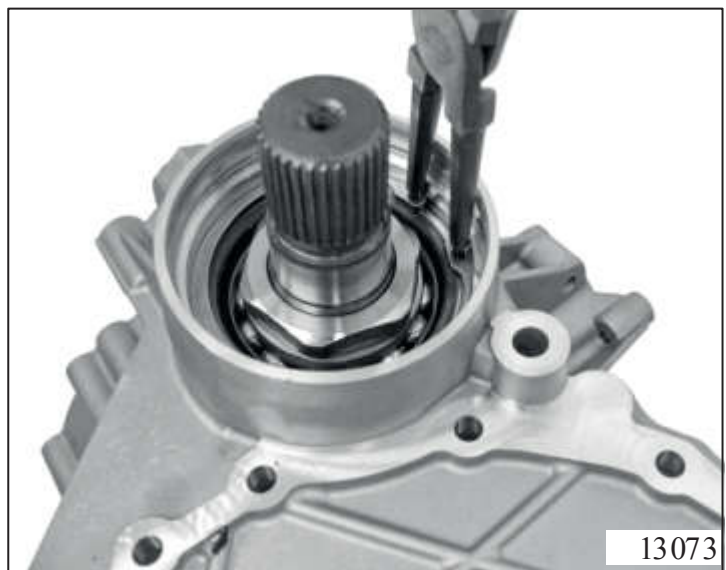



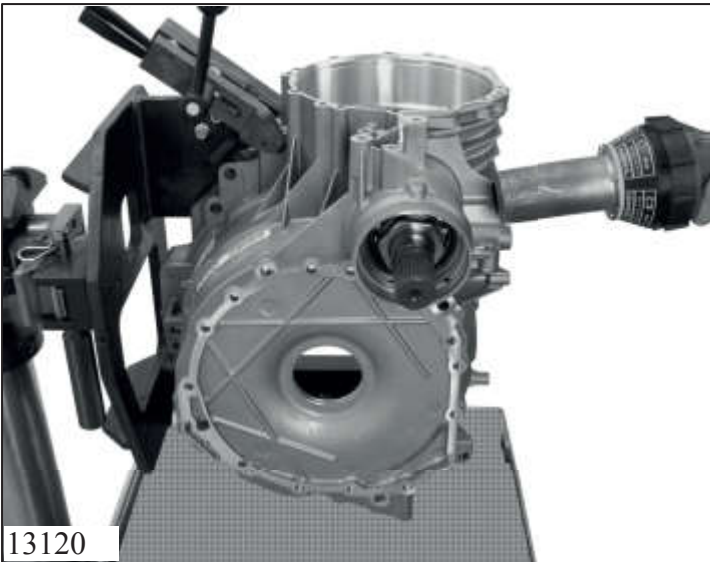

Turn device with converter housing through 90°.

**⚠ CAUTION**

**Danger of burns**

⇒ Wear safety gloves

Heat converter housing on bearing seat of pinion shaft with a hot air blower.

13120

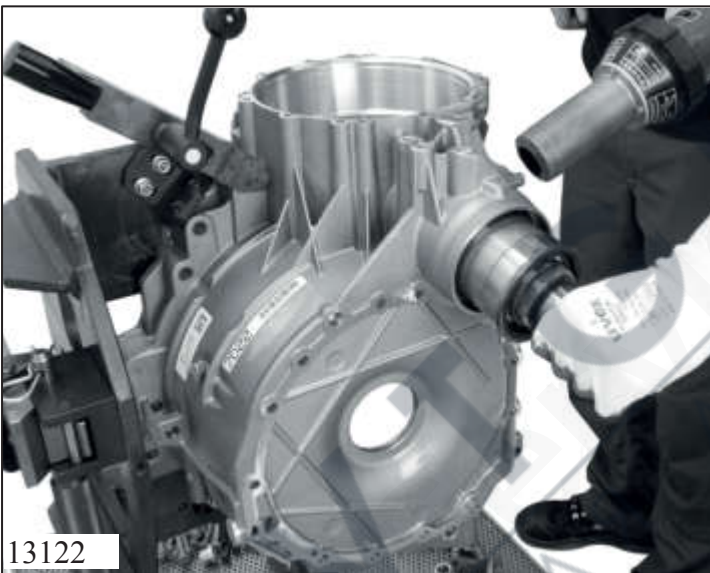

Pull out pinion shaft and put it down carefully.

Allow converter housing to cool.

13122

### 2.3.7 Dismantle pinion shaft

*Pinion shaft with left-hand thread*

Insert pinion shaft into mounting device AA00.561.260 and stop lock nut turning counter-clockwise using a hold-down device.



13123

Release pinion shaft with socket wrench AA00.561.169 *turning it counter-clockwise* - reducer section, toggle bar or ratchet and extension tube (> 1,000 mm length) and unscrew it from the lock nut.

Remove hold-down device, lock nut and pinion shaft.



*Pinion shaft with right-hand thread*

Insert pinion shaft into dismantling device AA00.561.260 and stop lock nut turning clockwise using a hold-down device.

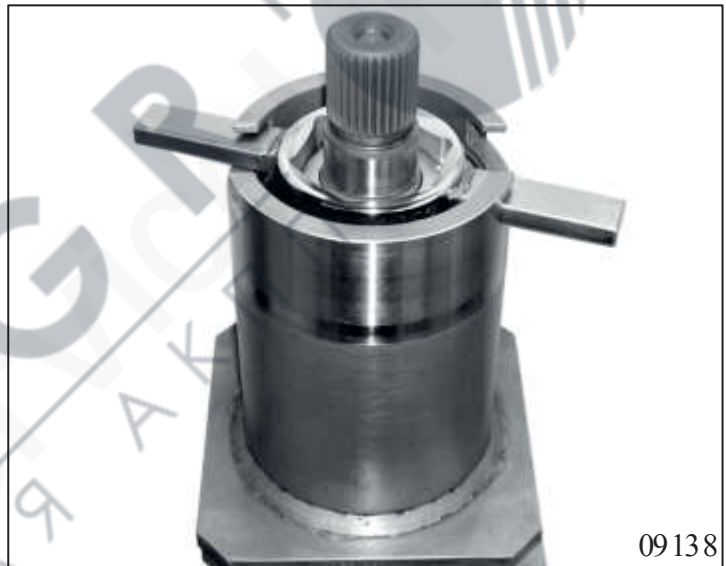

Release pinion shaft *turning it clockwise* with socket wrench AA00.561.169 - reducer section, toggle bar or ratchet and extension tube (> 1,000 mm length) and unscrew it from lock nut.

Remove hold-down device, lock nut and pinion shaft.





Insert pinion shaft into dismantling device 5x46.003.801.

Press out slot-in shaft using the mandrel press.

Remove pinion shaft and bearing from device.



Insert pinion shaft into dismantling device 5x46.003.801.

Press the internal bearing ring off pinion shaft using dismantling device 5x46.802.048 and mandrel press.



## 2.4 Remove oil pan, mechatronic unit and parking lock

### 2.4.1 Remove oil pan and oil filter

Unscrew 12 aluminum cap screws which secure oil pan.

Lever off oil pan.

Remove seal.

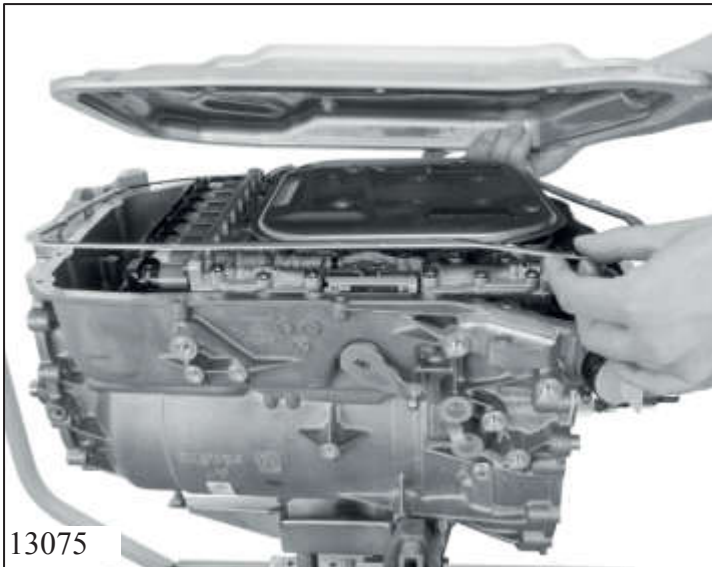

Carefully lever out and remove oil filter.



### 2.4.2 Remove mechatronic unit

Undo aluminum screw in guide sleeve.

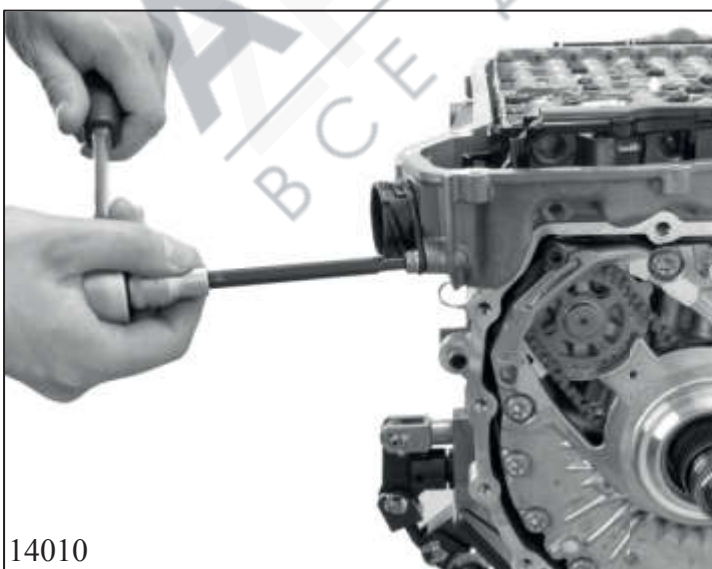

Place tool AA00.615.807 on guide sleeve.

Turn guide sleeve counter-clockwise with tool as far as possible and pull it out.

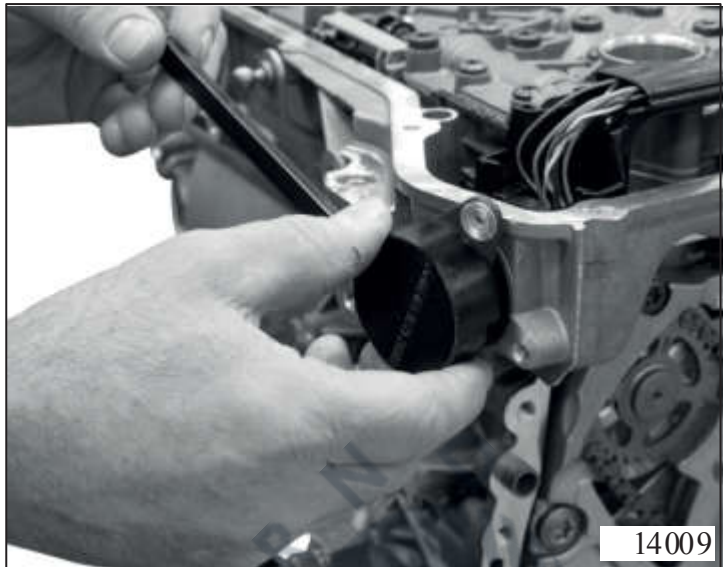

*Transmission with oil reservoir*

Disconnect cable plug from oil reservoir using long nose pliers.

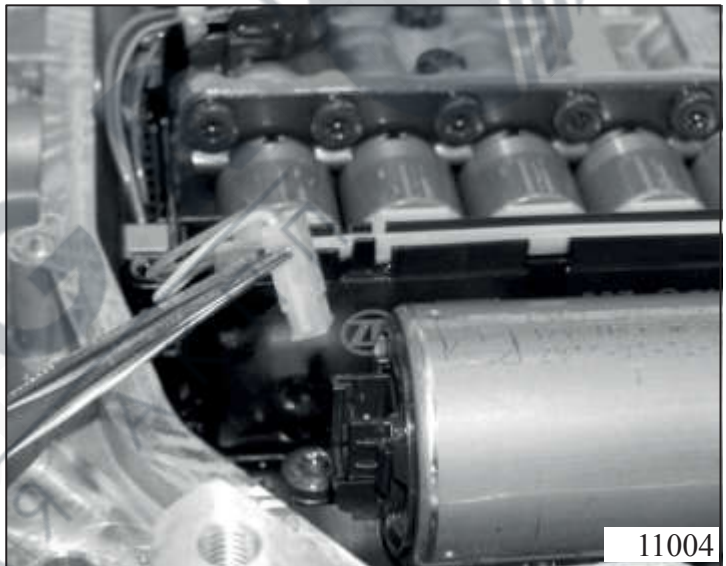

Remove 3 screws from oil reservoir.



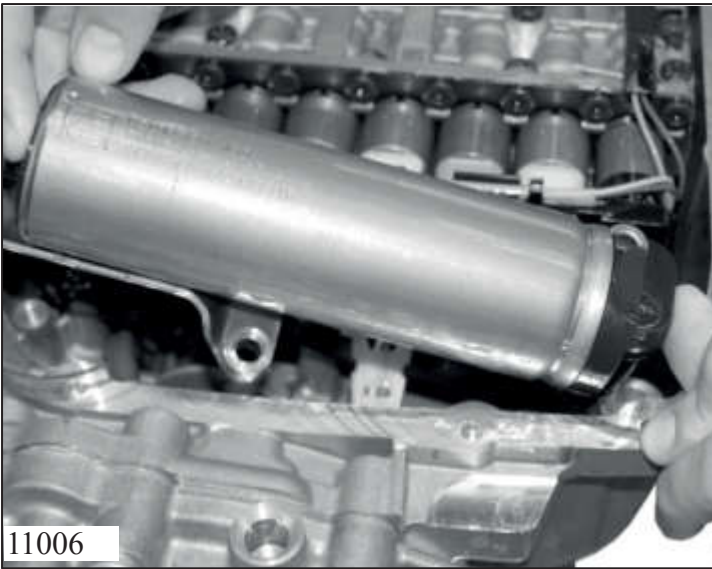

Carefully remove oil reservoir.



**NOTICE**

You could damage the pressure nozzle of the oil reservoir!

Pull O-ring off oil reservoir.

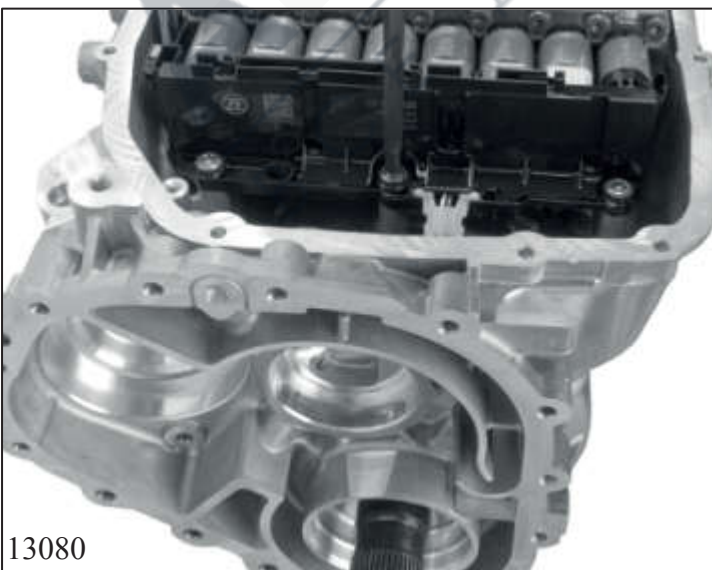

Undo 4 screws (thick screw head) from mechatronic unit and speed sensor on output side.

*3 screws on a transmission with oil reservoir.*

Remove speed sensor and insert into the notch in module.

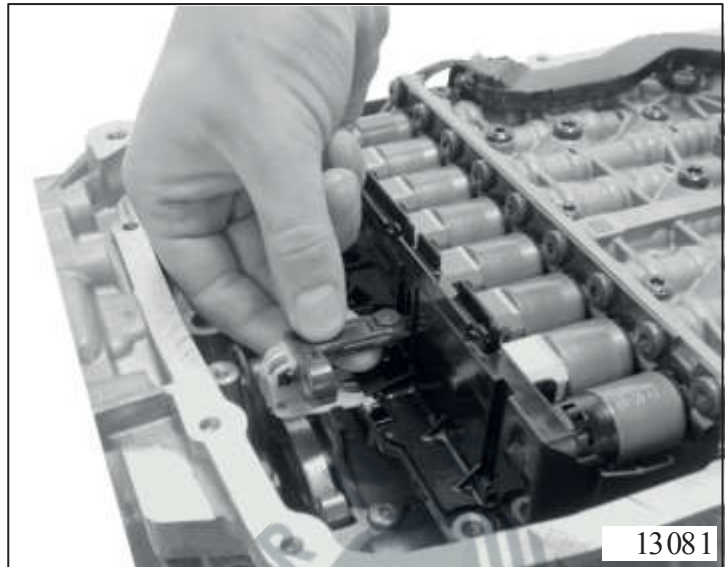

Remove screw from cable loom.

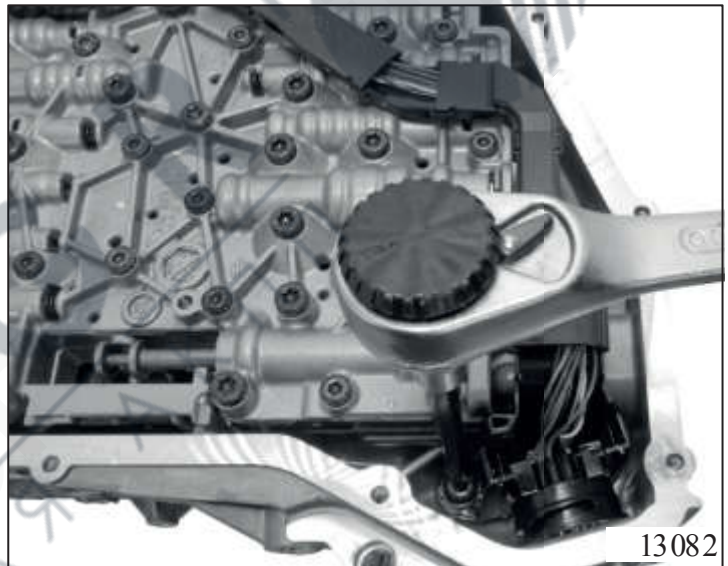

*Transmission with electric gearshift*

Push tool AA00.564.638 over selector shaft and locked it on transmission housing.

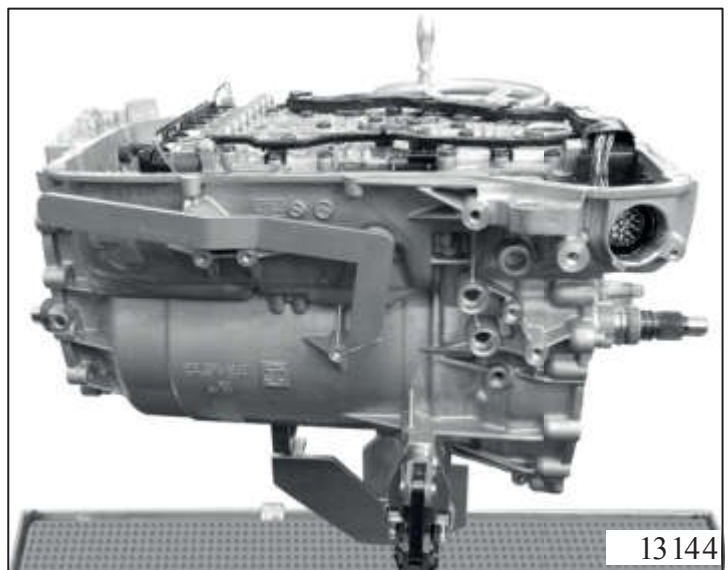



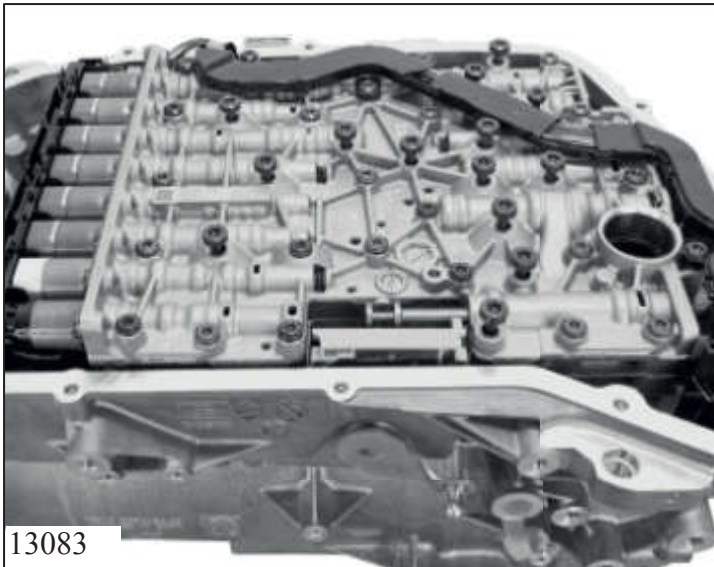

Undo 14 long screws (thick screw head) from mechatronic unit.

13083



**NOTICE**

The mechatronic unit may jam.

Carefully release mechatronic unit by levering it.

13084

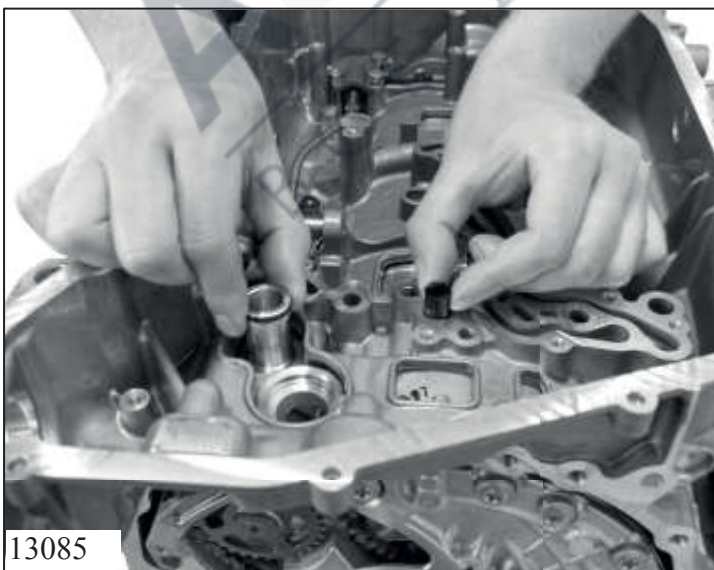

Remove pressure tube from mechatronic unit or transmission housing.

Pull out sealing sleeve by hand or using tool 5x46.001.210.

13085

### 2.4.3 Remove parking lock

Remove 3 screws from guide plate.

Remove guide plate.

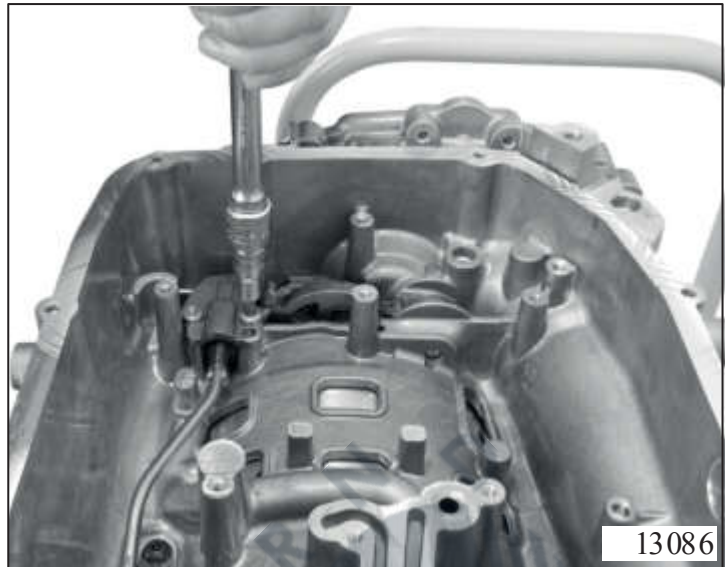

Press out parking lock bolt with a screwdriver.

Remove pawl and spring.

Wipe O-ring on parking lock bolt.

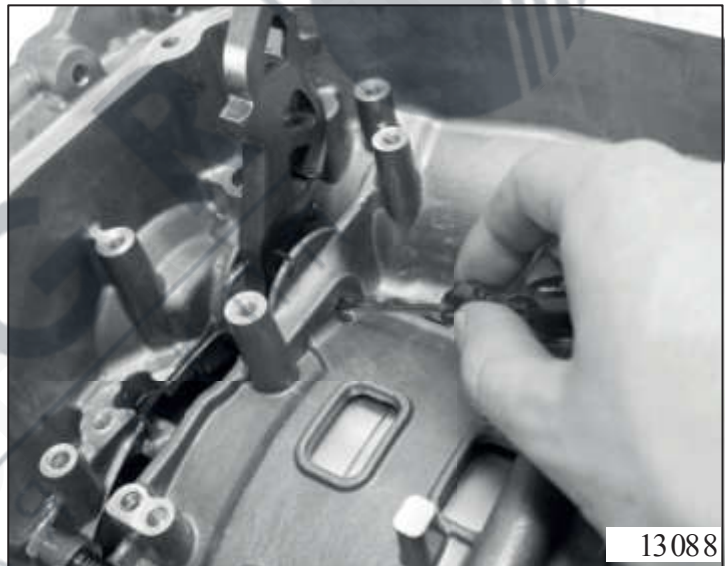

*Transmission with manual gearshift*

Drive out selector shaft clamping pin using a punch mandrel.

Remove selector shaft and catch disk.

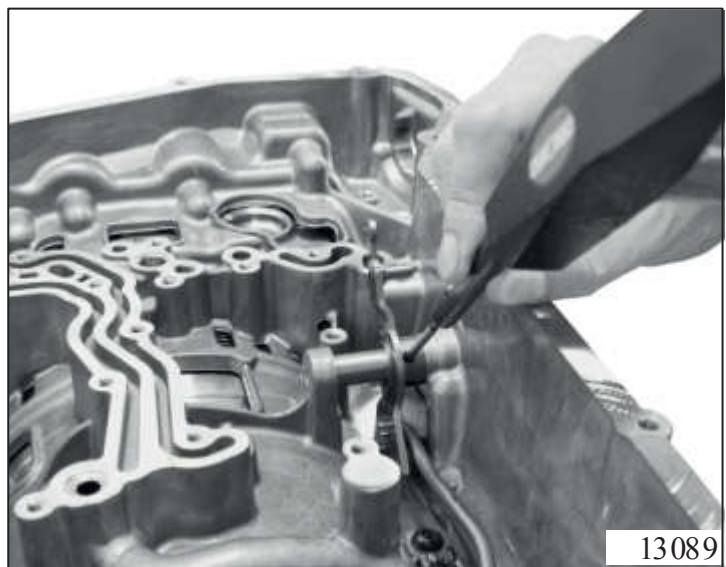

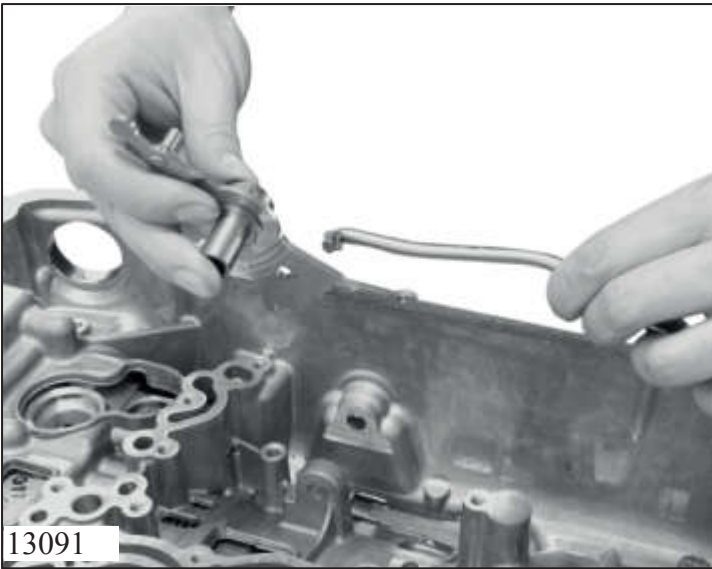

13091

Detach connection rod from catch disk.

*Transmission with electric gearshift*

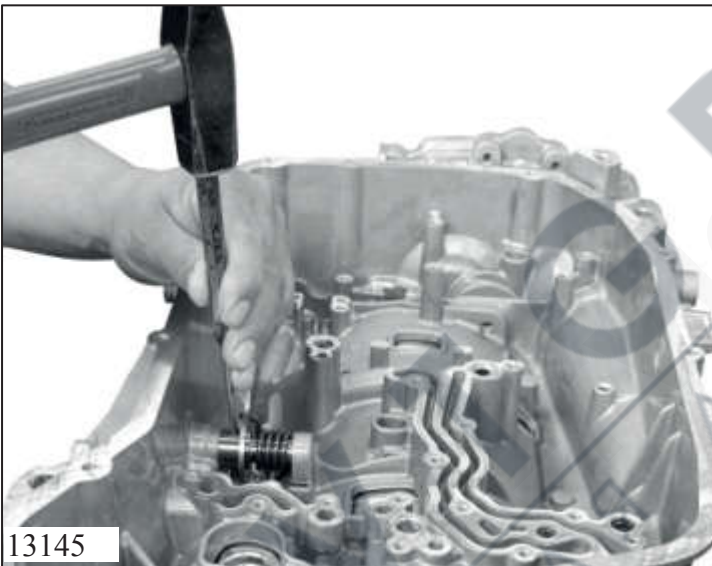

13145

Remove selector shaft holding tool.

Drive out selector shaft clamping pin using a punch mandrel.

Remove clamping pin.

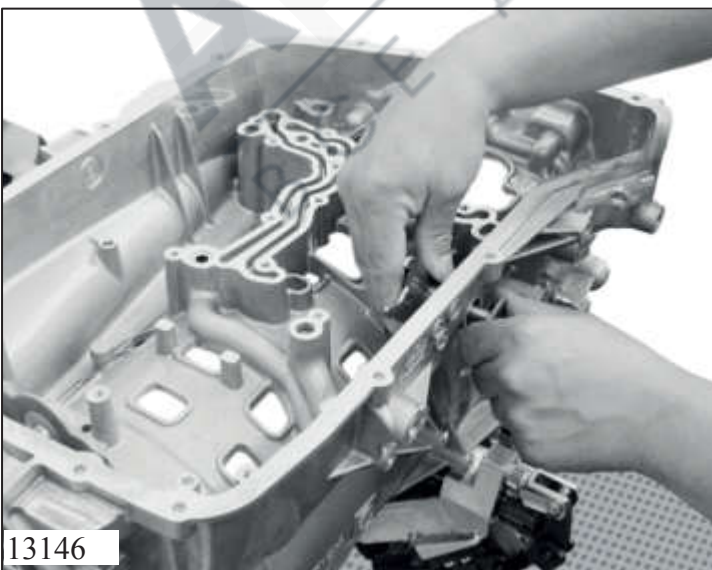

13146

Remove selector shaft from parking disc.

Remove parking lock with leg spring.

Detach connection rod from parking disc.

Use suitable tools to remove sealing ring for selector shaft.

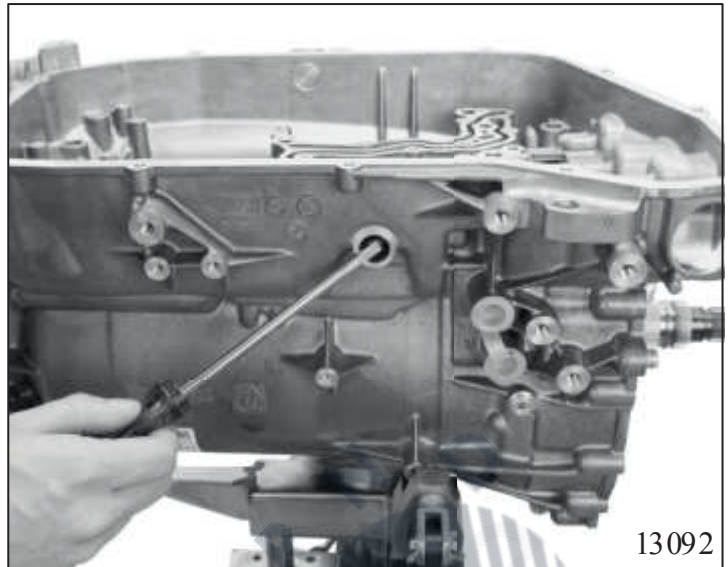

Unscrew PZT sealing screw from transmission housing.

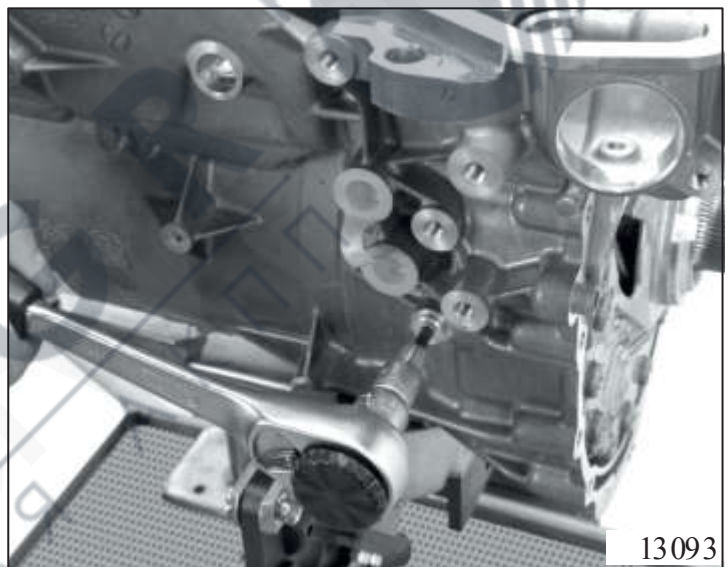

## 2.5 Remove and dismantle oil supply

### 2.5.1 Remove oil supply

Remove 14 screws from oil supply.



Position lifting device AA00.549.802 and lock it with slide.

Turn crank AA00.359.399 clockwise until oil supply is released.

Lift out oil supply and put it down.

Remove lifting device.

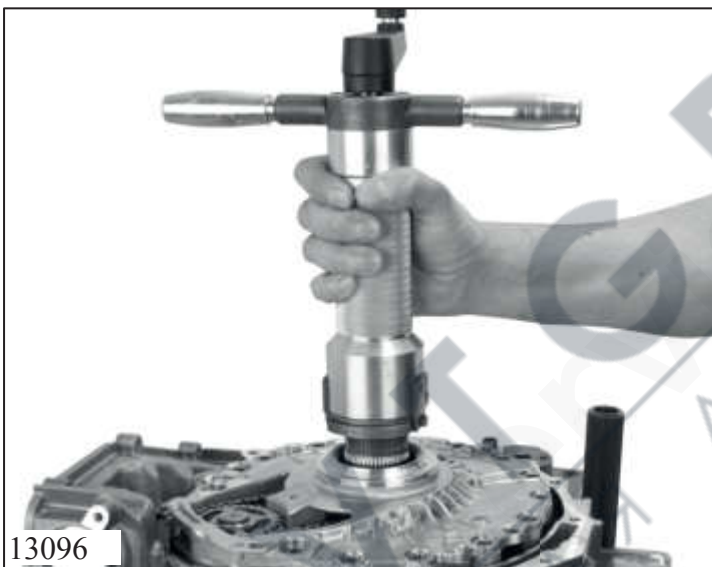

### 2.5.2 Dismantle oil supply

#### ⚠ CAUTION

Cylinder may jump out under pressure.

Release cylinder B from intermediate plate with compressed air and remove it.

Remove piston B.

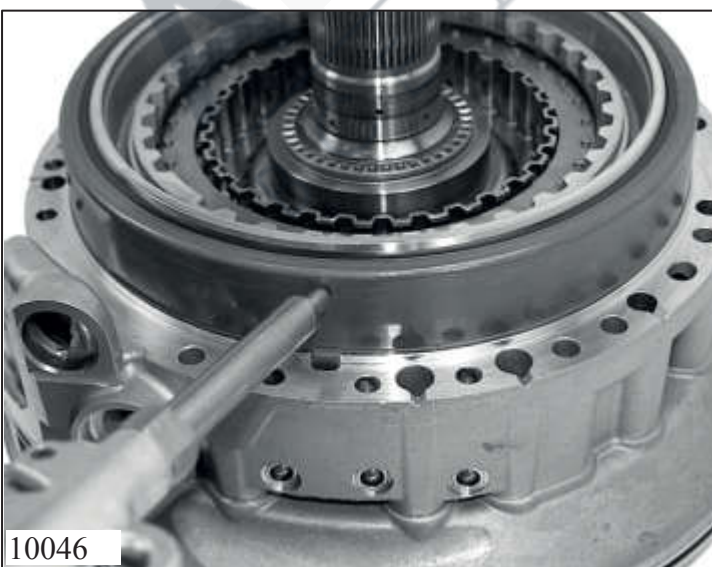

Pull profile and lip sealing ring off piston.



Remove axial needle bearing from multidisk carrier.

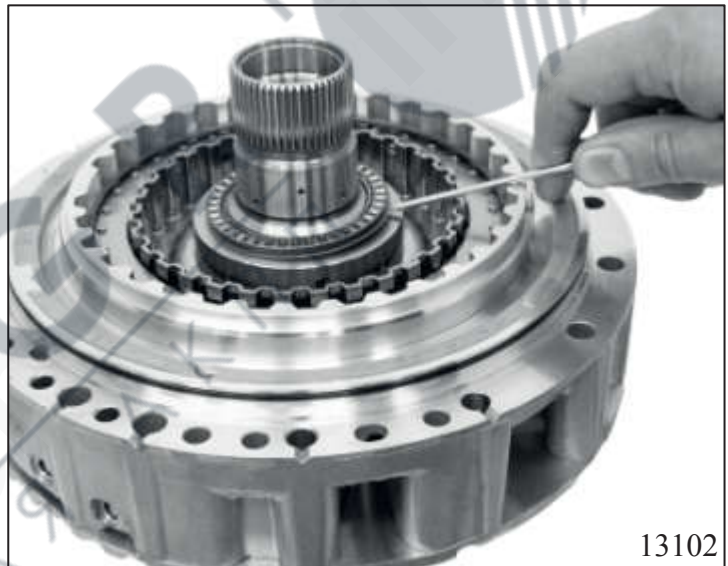

Pull O-ring off intermediate plate.

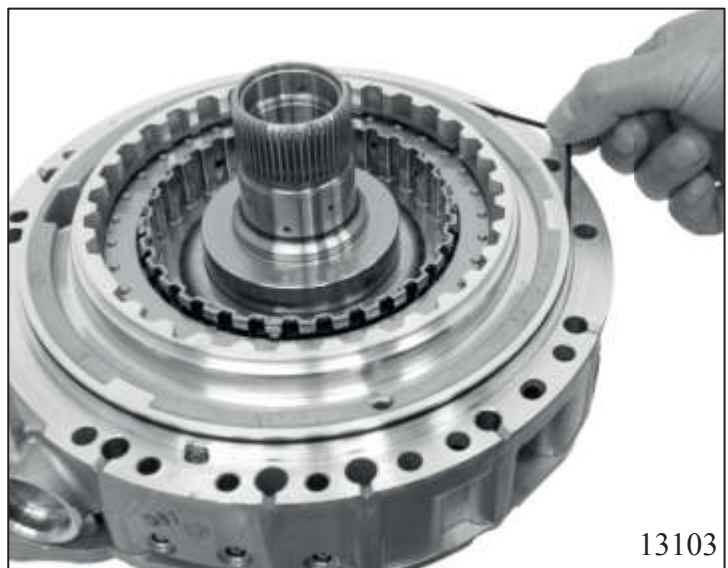

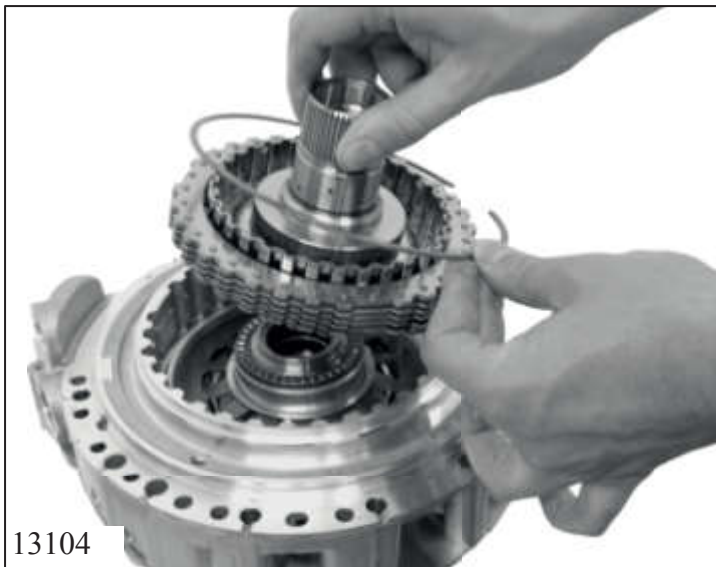

13104

Lever snap ring out of brake A.

Remove multidisk carrier A, sun shaft 1 and multidisk package.

Remove axial needle bearing from intermediate plate.

Remove angle disc from multidisk carrier.

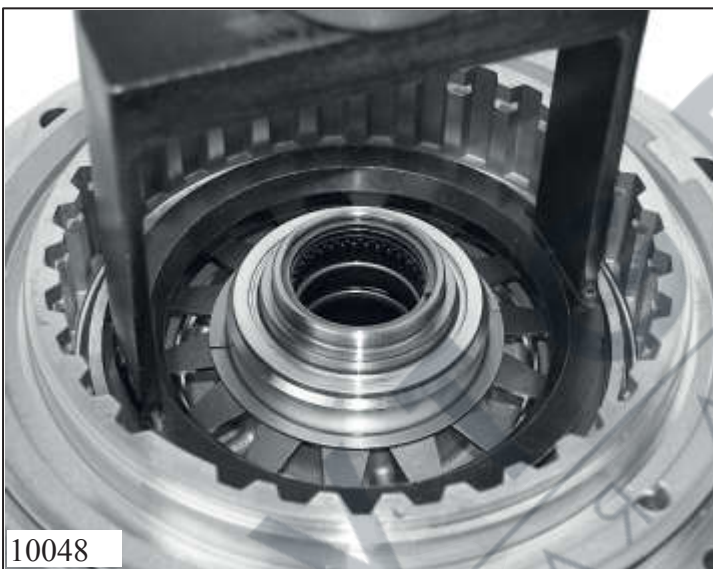

10048

Remove coil spring and external disk.

Push down piston A using dismantling bar 5x46.001.502 under mandrel press.

Remove retaining rings and disk spring.



10049

Remove piston A by turning and pulling it.

Pull off 2 lip sealing rings.

Undo 5 screws in cylinder A and 1 screw outside cylinder.

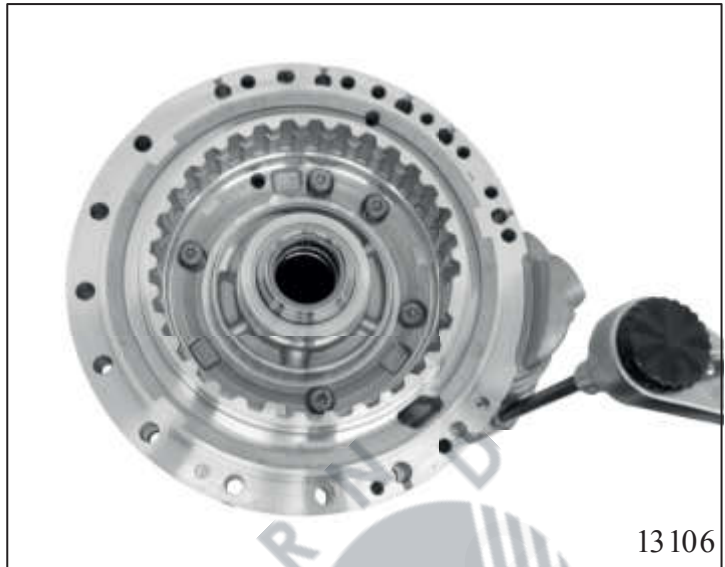

Turn unit over.

Remove screw from centering plate.

Lift off centering plate.

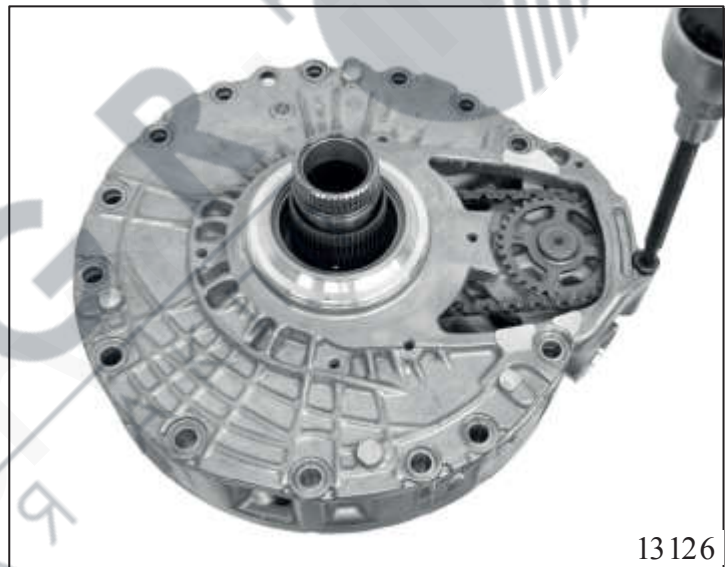

**NOTICE**

If the axial needle bearing is damaged on the guide wheel shaft or intermediate plate, the complete unit must be replaced.

Carefully pull out pump with chain drive using tool AA00.566.429 and remove it.

Remove 2 O-rings and a sealing element from underside of the pump.





## 2.6 Remove and dismantle tower

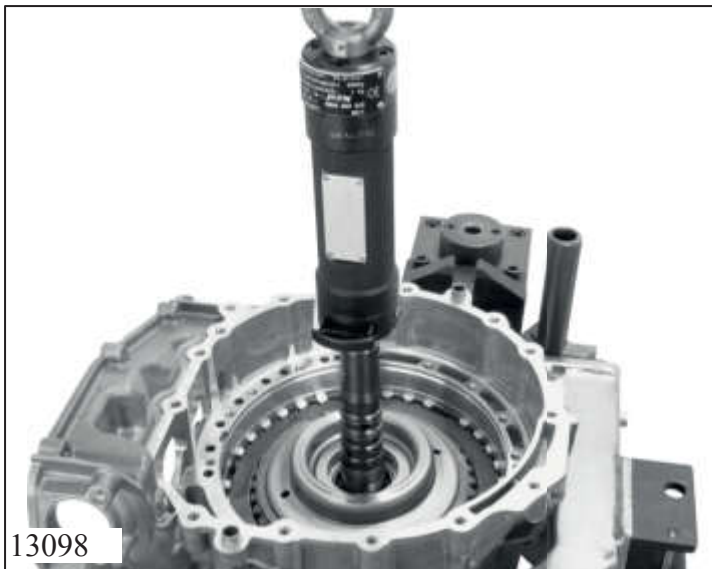

Place tower lifter 5x46 003 957 on the input shaft and secure with damper.

Extract tower with crane or lifting aid.



Place tower in device 5x46 004 264.

Extract power lifter.

Extract multidisk carrier B incl. internal ring gear (a component) with brake B.

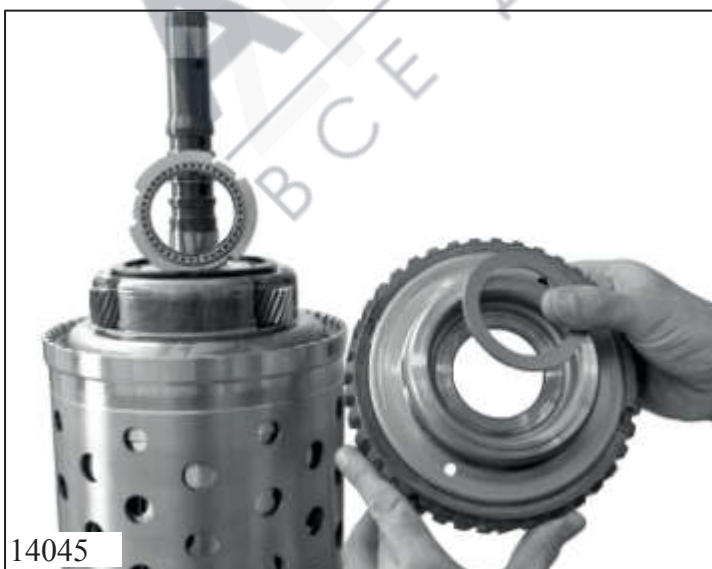

Remove washer from internal ring gear.

Extract axial needle bearing with fixing plate from planet carrier.

**NOTICE**

Hold pot 1 to prevent it from falling.

Place support ring AA00.555.684 (protection from levering tool) on pot 1.

Lever out snap ring with a screwdriver opposite the snap ring opening and remove it.



Remove gearset 1.

Remove sun gears 1 and 2.

Remove drive shaft with gearset 2.



Place drive side of drive shaft in mounting device.

Pull 7 rectangular rings off drive shaft.

Remove axial needle bearing and angle washer from annulus 2.

Remove axial needle bearing from gearset 2.





10026

Lever out thrust washer from planetary support 2.

Remove snap ring with suitable tools.

Remove gearset upwards.

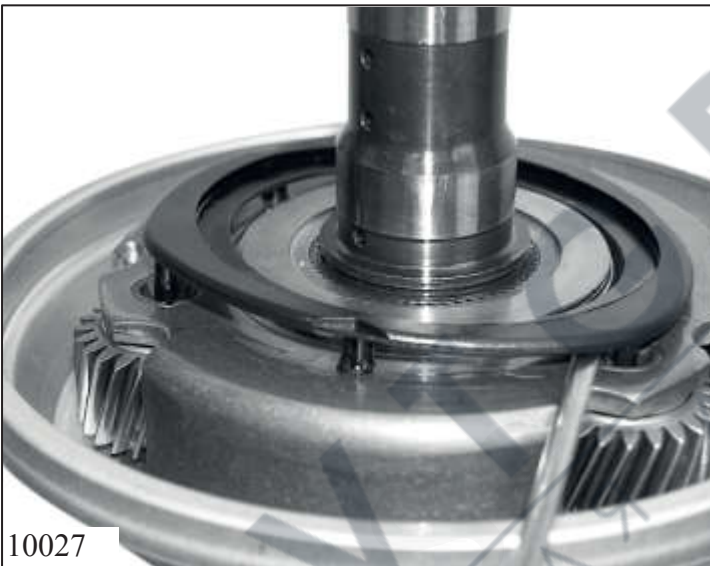

10027

**NOTICE**

Locking spigots may break, so screwdrivers should be placed on several points.

Lever oil collection tray out of planetary support 2 with a screwdriver.

Lever oil collection tray out of planetary support 1 with a screwdriver.



10028

Remove annulus 2 with sun gear 3 from post 2.

Remove angle washer from sun gear 3.

Release snap ring.

Put down annulus and sun gear.

Pull pot 2 upwards out of pot 1.



Remove coupling D from pot 1.



Place pot 2 in supporting fixture  
5x46.004.264.

Place support ring AA00.558.211 on pot 2.

Lever out snap ring with a screwdriver  
and remove it.



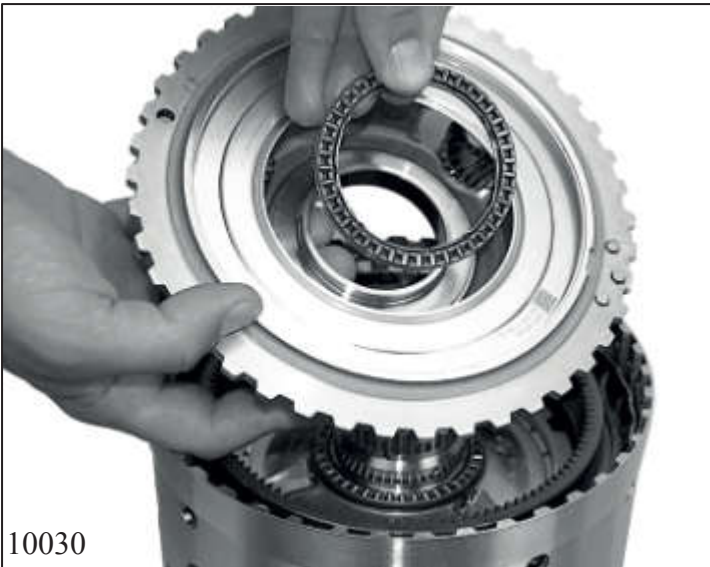

10030

Extract gear set 3.

Extract axial needle bearing from gear set.

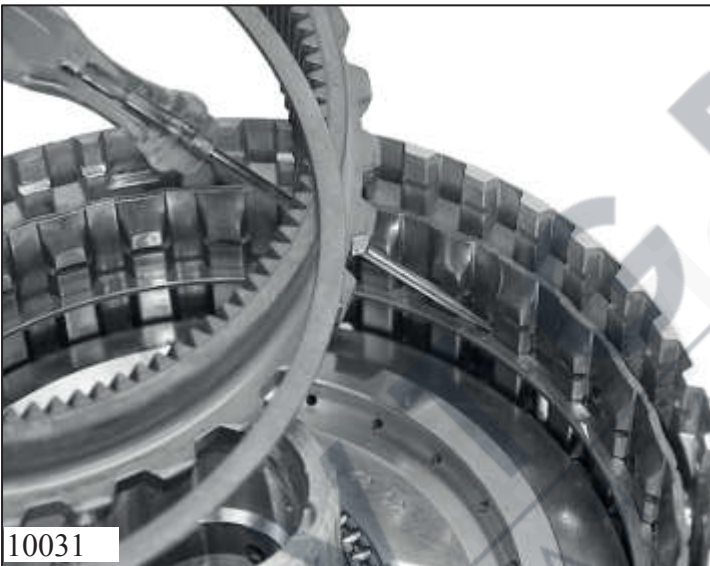

10031

Detach snap ring 1 and extract ring gear 3.

Detach snap ring 2 (support for internal ring gear).

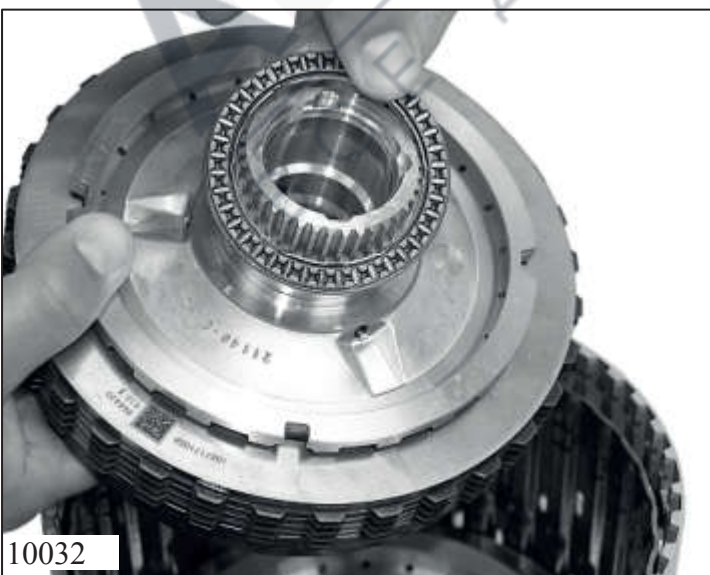

10032

Extract clutch E.

Extract axial needle bearing on the upper side of clutch E.

Remove clutch C.

Remove a combination bearing from top and bottom of clutch C.



Remove sun shaft with sun gear 4.



Remove snap ring with snap ring pliers 5x46.001.376.

Remove annulus from gearset 4 from pot.

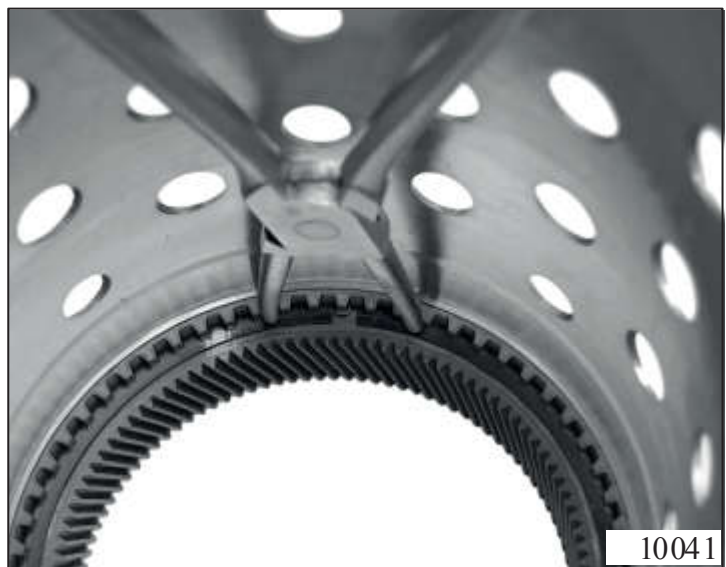

## 2.7 Remove clutches

### 2.7.1 Remove clutch E

Press dismantling bar 5x46.000.167 on baffle plate and remove round wire ring.

Remove piston with baffle plate.

Remove baffle plate from piston.

Wipe lip sealing ring from baffle plate.



Remove disk spring and multidisk package.

Remove multidisk carrier.

Wipe 2 O-rings.

### 2.7.2 Remove clutch C

Press dismantling bar 5x46.000.167 on baffle plate and remove snap ring.

Remove piston with baffle plate.

Remove baffle plate from piston.

Wipe lip sealing ring from baffle plate.



Remove disk spring and multidisk package.

Remove multidisk carrier.

Pull hub out of multidisk carrier.

Wipe 4 O-rings (2 inside, 2 outside) from hub.



### 2.7.3 Remove clutch D

Remove snap ring.

Remove multidisk package.



Position tool AA00.349.340 with both pins in baffle plate and secure it.







Place clutch D with tool in mandrel press.

Turn tool clockwise applying slight pressure from mandrel press until detents have engaged.

Remove baffle plate and disk spring.

Remove the O-ring from the baffle plate.



Pull out piston D by hand.

Wipe O-ring from piston D.

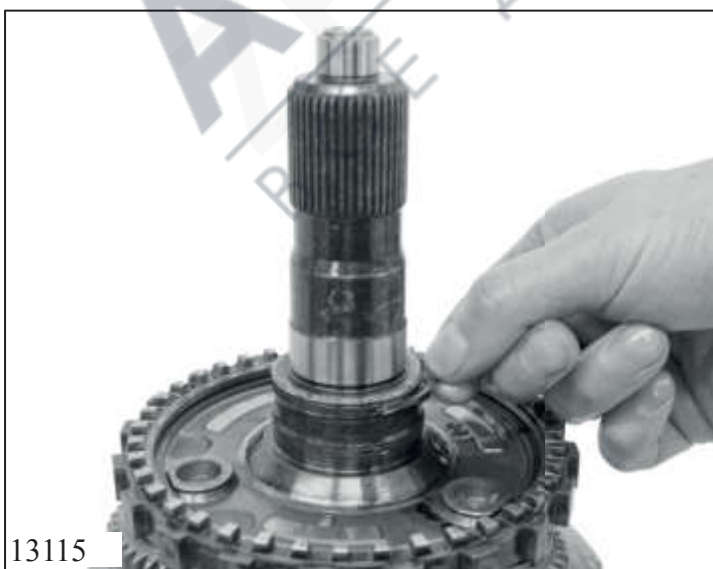

Pull 2 rectangular rings off output shaft.

Protect transmission housing sealing surface with a suitable support.

Pull off external sealing sleeves using tool 1x56.122.209/1x56.122.227.

Drive out internal sealing sleeves with suitable tool.

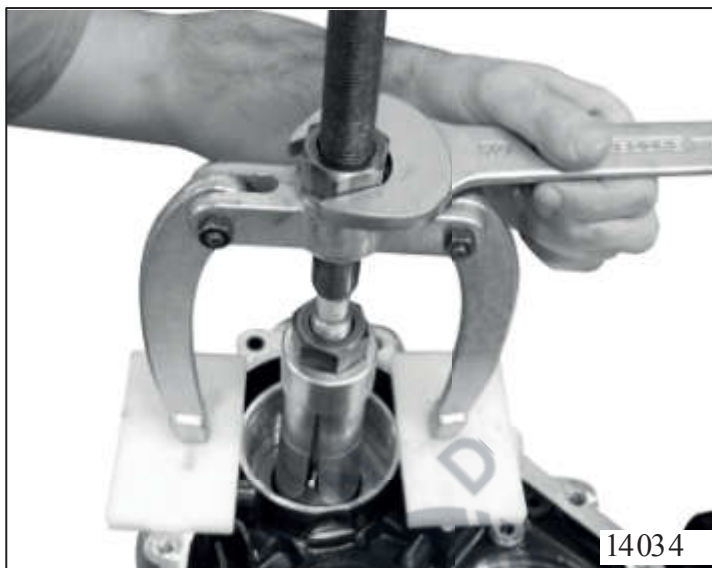

AVTIGRIP  
ВСЕ ДЛЯ АКПП

**3. Assembly**  
**3.1 Preparations**

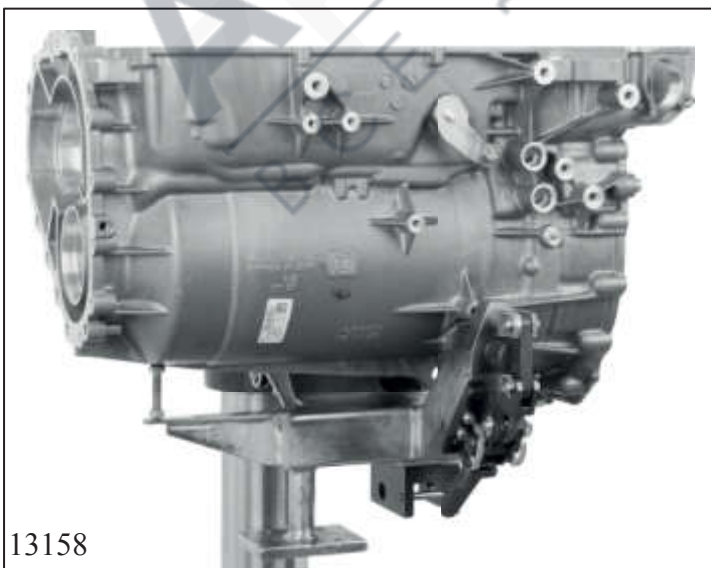
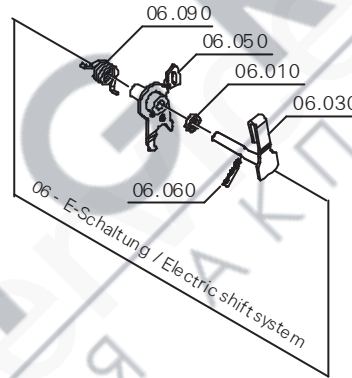
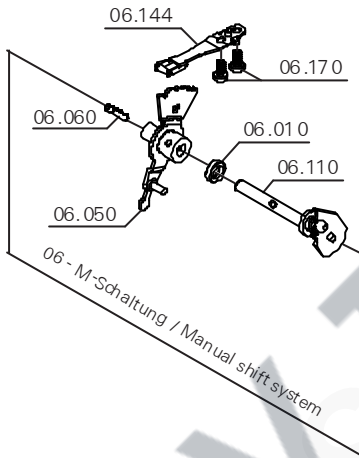
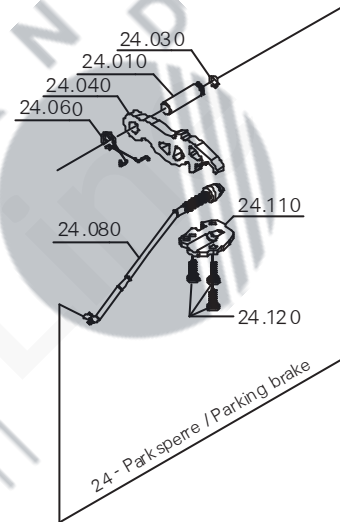
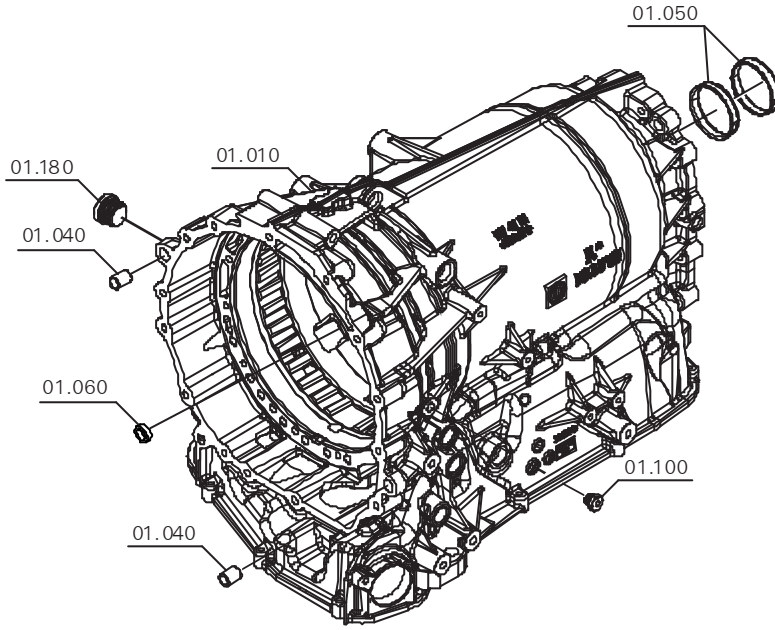

Attach transmission housing (01.010) with retaining bracket 5t66.000.128 to assembly trolley AA00.607.881.

*New housing*

Place outside sealing sleeve (01.050) onto tool AA00.574.045 and drive it into transmission housing.



Rotate transmission housing by 180°.

Place inside sealing sleeve (01.050) onto tool AA00.554.817 and drive it into transmission housing.



*New housing*

Drive two bushes (01.040) into transmission housing on converter housing sealing surface.

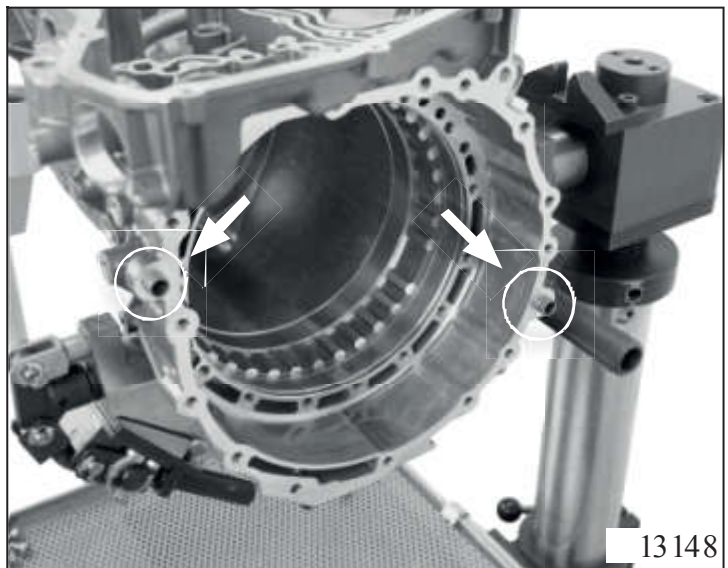

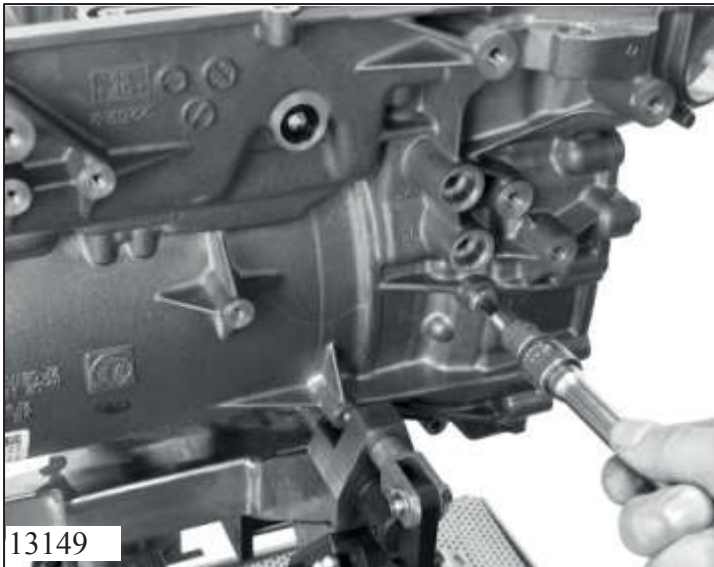

#### NOTICE

Depending on the oil filling method, turn in the screw hand-tight or to tightening torque.

Screw new sealing screw PZT (01.100) into transmission housing.

(See section 1.5 for tightening torques)

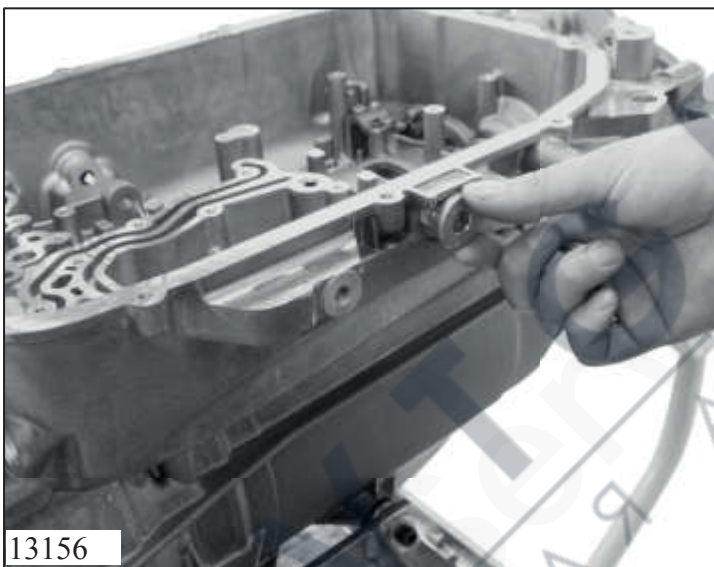

Screw new oil filler sealing screw (01.180) into transmission housing.

(See section 1.5 for tightening torques)

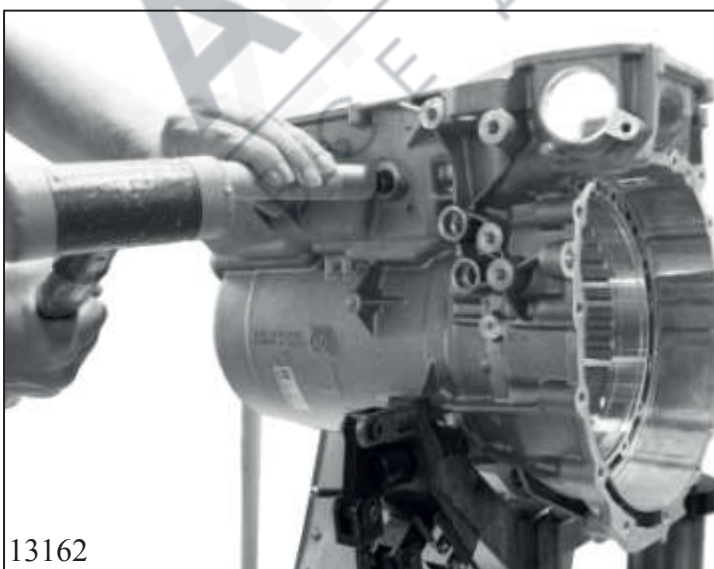

### 3.1.1 Install parking lock and gearshift

Place new gearshift lever shaft sealing ring (06.010) in tool 5x46.002.561 and drive it into transmission housing.  
*Manual gearshift and new housing*

Fit new O-ring (24.030) on parking lock bolt (24.010).



Fit pawl (24.040) with leg spring (24.060) in transmission housing.

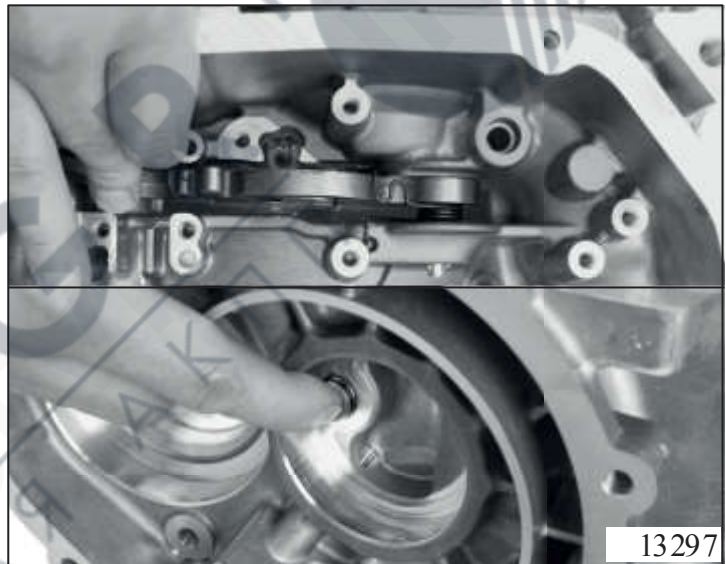

Secure pawl by pressing in parking lock bolt on output side.



### *Manual gearshift and new housing*

Refer to section 1.4.7. Adjustment work

Secure locking spring (06.144) with 2 torx screws (06.170) with locking spring can be turned easily.



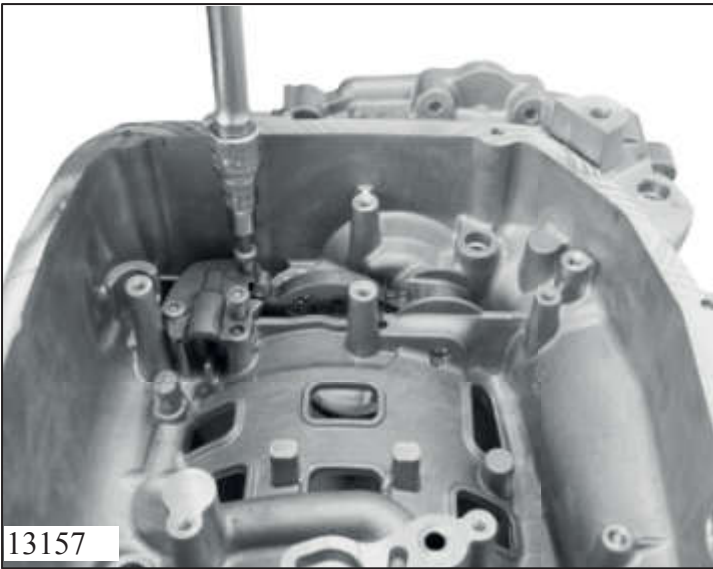

Press down pawl and place guide plate (24.110) on it.

Secure it with 3 new hexalobular screws (24.120).

(See section 1.5 for tightening torques)

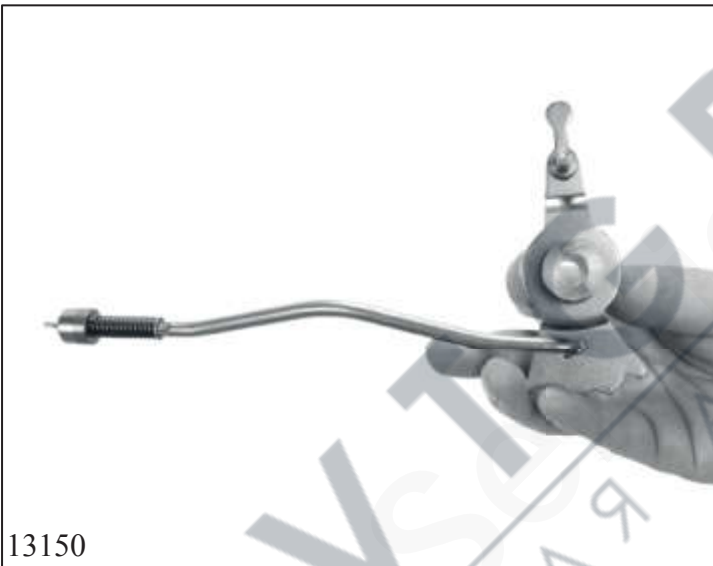

Attach connecting rod (24.080) to parking and catch disk (06.050) and turn it.

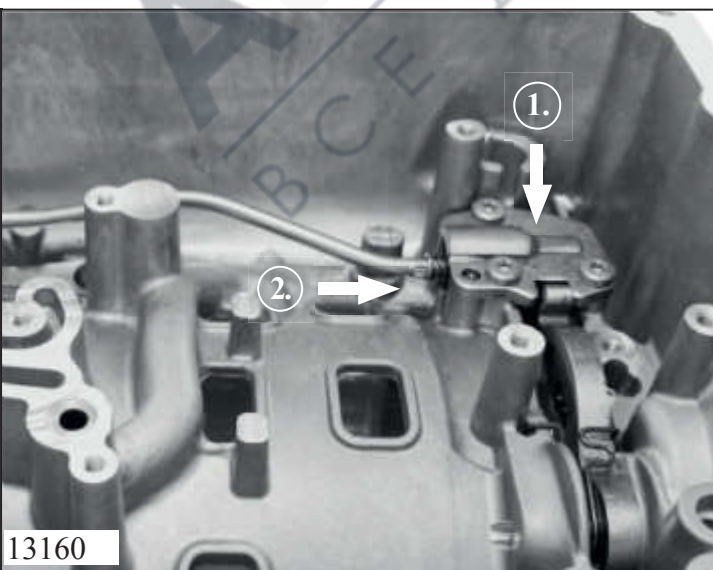

1. Press down the pawl.
2. Fit connecting rod between guide plate and pawl.

### *Manual gearshift*

Slide gearshift lever with selector shaft (06.110) through catch disk.

Position selector shaft with the catch disk borehole and selector shaft borehole are in line.

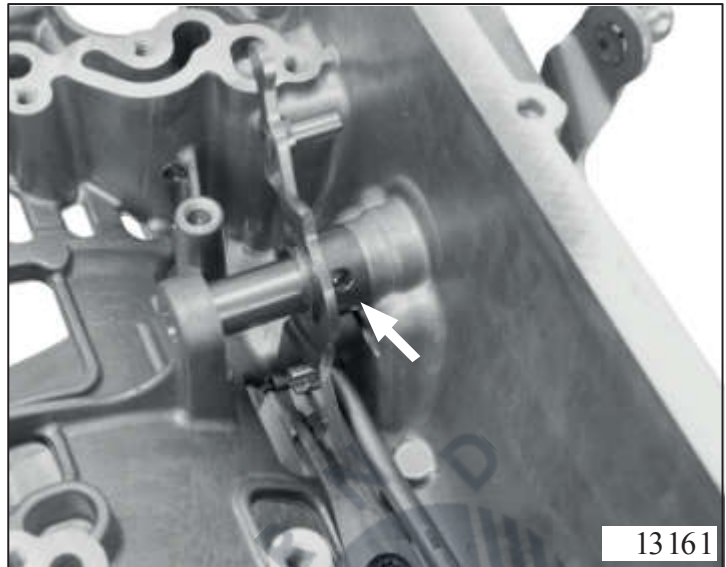

### *Electric gearshift*

Slide selector shaft (06.030) through parking washer and leg spring (06.090).

Position selector shaft with parking disk borehole and selector shaft borehole are in line.



Drive in new clamping sleeve (06.060) in the position shown using tool 5x46.001.368.





*Manual gearshift*

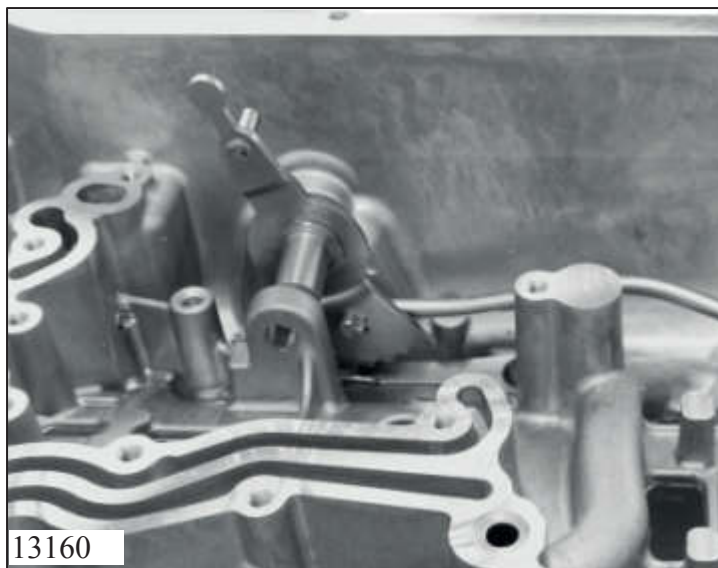

13160

Fit catch disk in P position on locking spring.

*Electric gearshift*

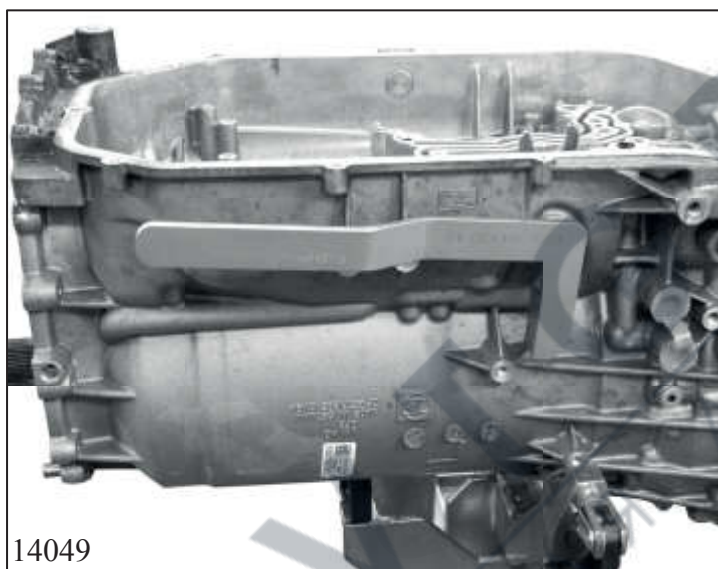

14049

Slide tool AA00.564.638 over selector shaft and lock on the transmission housing.



## 3.2 Assemble clutches and oil supply

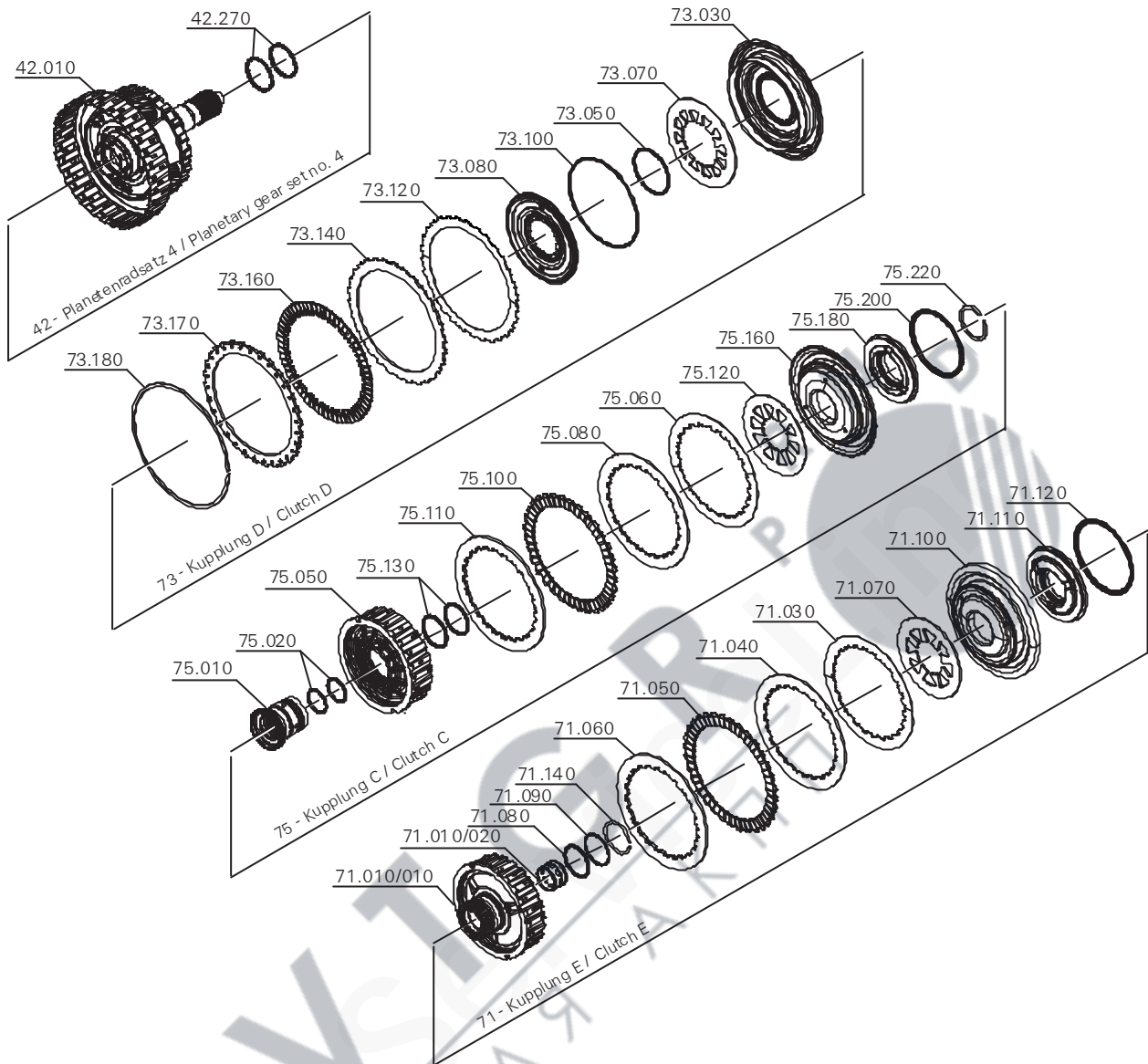

### 3.2.1 Clutch D

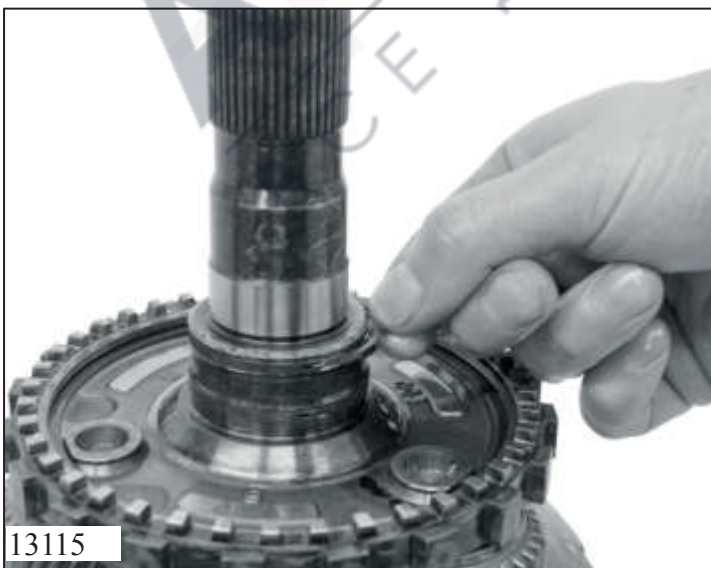

The sealing element in the output shaft (cylinder D) is riveted and cannot be replaced. If it is damaged the complete component (output shaft with gearset and cylinder D) must be replaced.

Fit 2 new rectangular rings (42.270) on output shaft (42.010).

13115

Place output shaft in supporting fixture 5x46.004.264.



Fit new O-ring (73.050) on piston D (73.030).

Press piston D into cylinder D.

Insert disk spring (73.070).



Fit new O-ring (73.100) on baffle plate (73.080).

Position recesses in the baffle plate over appropriate spigot.

Press down baffle plate using tool AA00.349.340 using mandrel press and turn it counter-clockwise until small spigot is positioned between securing lugs.

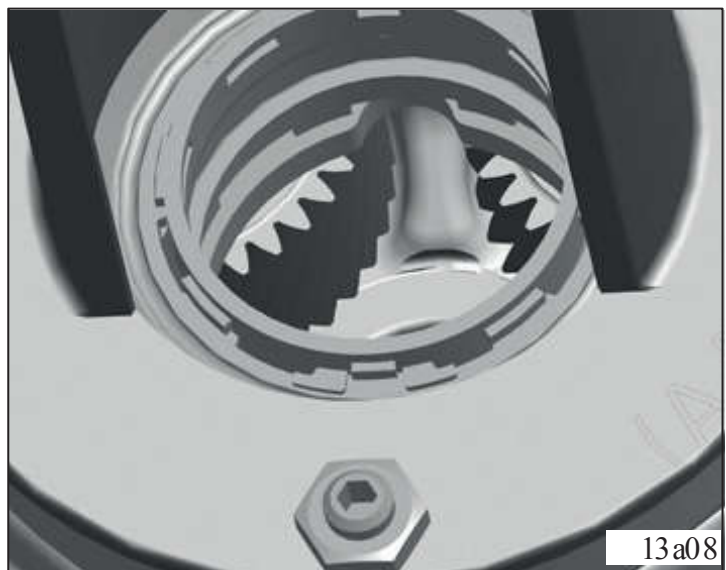



#### **NOTICE**

Refer to section 1.4.2. Adjustment work

Insert multidisk package.  
Start with a coil spring (73.120), then insert external disks (73.140) and lining disks (73.160) alternately.  
Finally fit an end disk (73.170).

Secure end disk with a snap ring (73.180).

### 3.2.2 Clutch C

Fit 4 new O-rings (2 internal 75.020, 2 external 75.130) on hub (75.010).



Fit hub into cylinder C (75.050).

Fit disk spring (75.120) into cylinder.

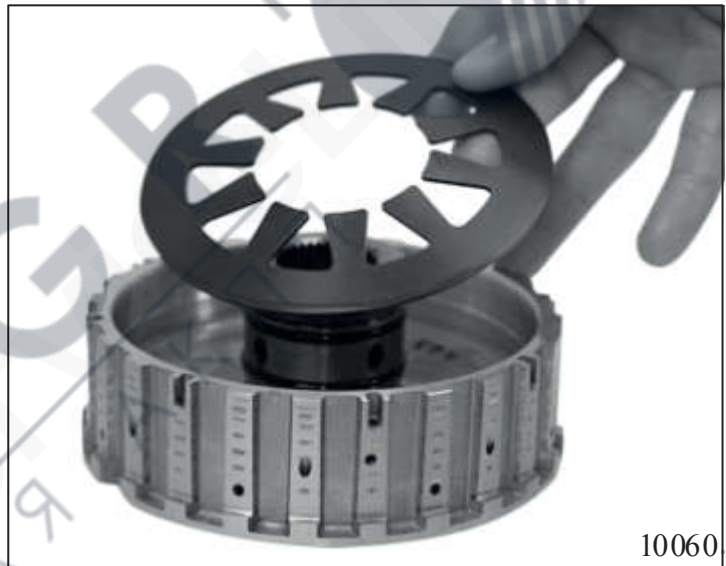

#### **NOTICE**

Refer to section 1.4.3. Adjustment work

Insert multidisk package.  
Start with a coil spring (75.110), then insert lining disks (75.100) and internal disks (75.080) alternately.  
Finally fit a coil spring (75.060).

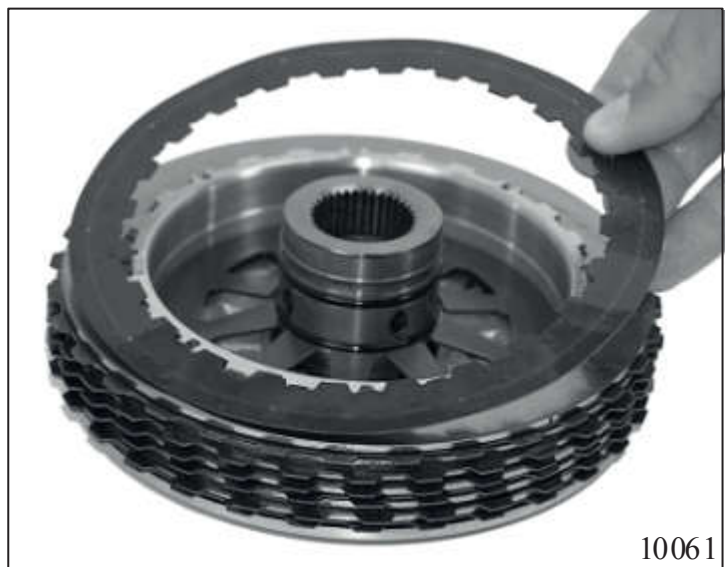



10062

**NOTICE**

The sealing element on piston C is vulcanized and cannot be replaced separately.

Press fit piston C (75.160) onto cylinder C.



10063

Press support washer (75.180) with a new lip sealing ring (75.200) into piston C.



10064

Press down support washer with assembly bar 5x46.000.167 using mandrel press and secure it with a new snap ring (75.220).

Place assembly device AA00.637.175 over hub of cylinder C and fit snap ring with thrust piece.

### 3.2.3 Clutch E

Fit 2 new O-rings (71.080, 71.090) on cylinder E (71.010).

Fit disk spring (71.070) into cylinder E.

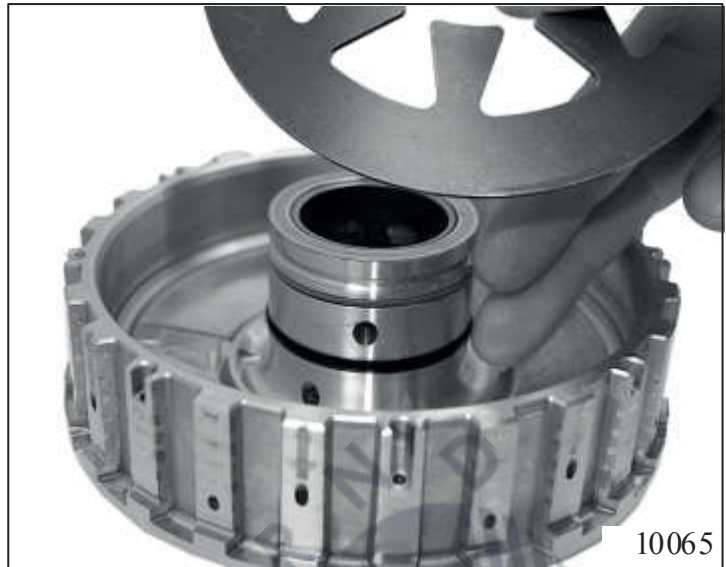

#### NOTICE

Refer to section 1.4.4. Adjustment work

Insert multidisk package.  
Start with a coil spring (71.060), then insert lining disks (71.050) and internal disks (71.040) alternately.  
Finally fit a coil spring (71.030).



#### NOTICE

The sealing element on piston E is vulcanized and cannot be replaced separately.

Press fit piston E (71.100) onto cylinder E.







Press support washer (71.110) with a new lip sealing ring (71.120) into piston E.



Press down support washer with assembly bar 5x46.000.167 using mandrel press and secure it with a new snap ring (71.140).

Place assembly device AA00.637.175 over hub of cylinder E and fit round wire ring with thrust piece.



### 3.3 Assemble tower and oil supply

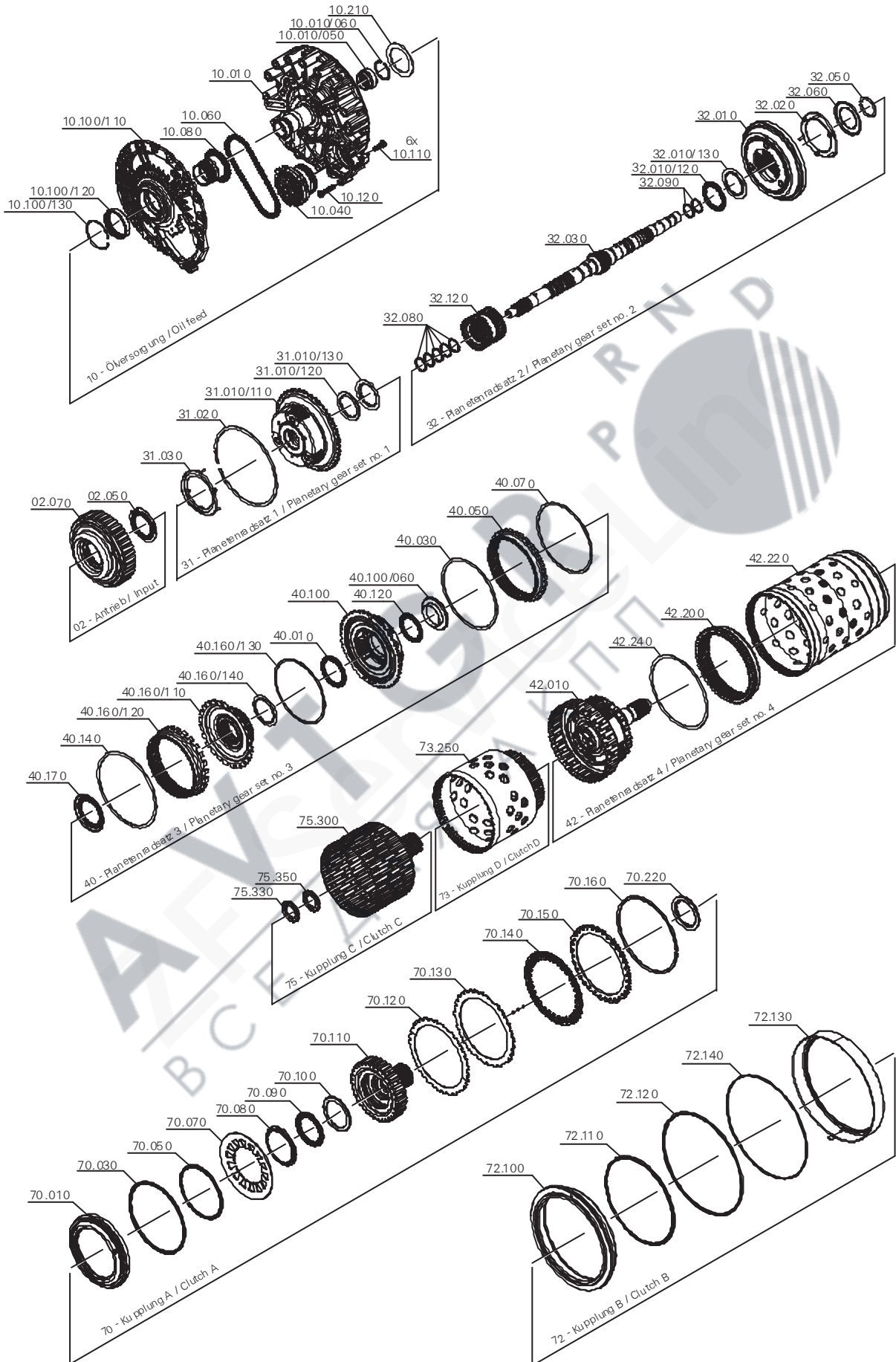

### 3.3.1 Assemble tower

Fit gearset 4, annulus (42.200) with phase at the bottom in pot 1 (42.220).

Secure annulus with a new snap ring (42.240).

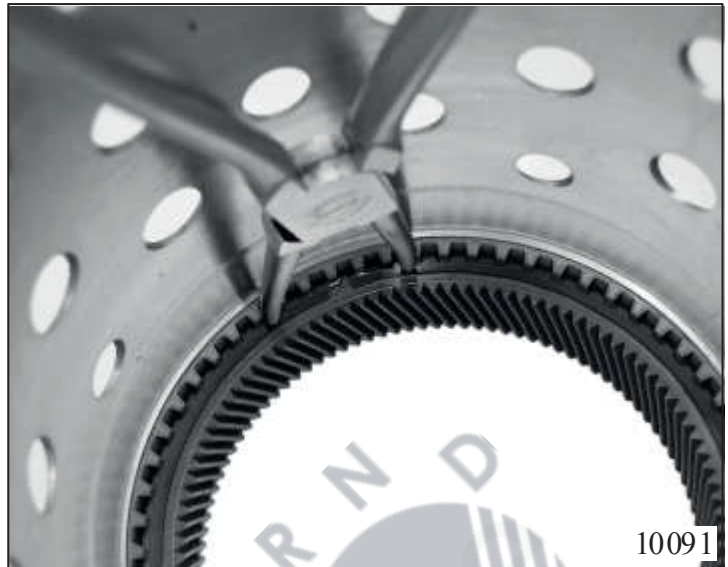

Insert pot 2 (73.250) into supporting fixture 5X46.004.264.

Insert sun shaft (75.300) into pot 2.

Insert axial needle bearing (75.350) into sun shaft.



Align lined disks of clutch C before insertion

Insert clutch C into sun shaft.

Fit combination bearing (75.330) on to hub of internal multidisk carrier C.

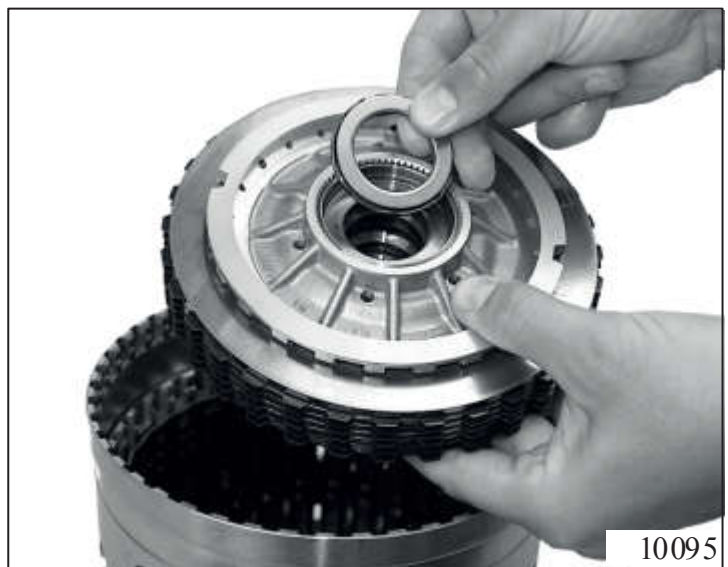

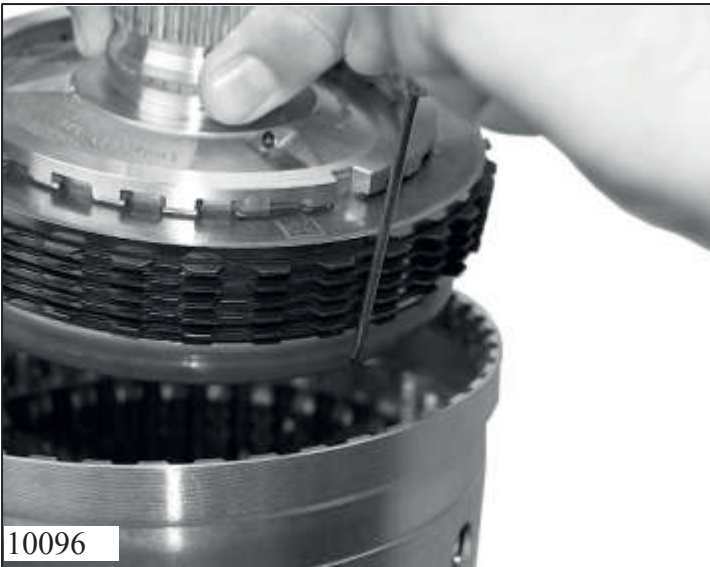

10096

Align lined disks of clutch E before insertion.

Insert clutch E into sun shaft.

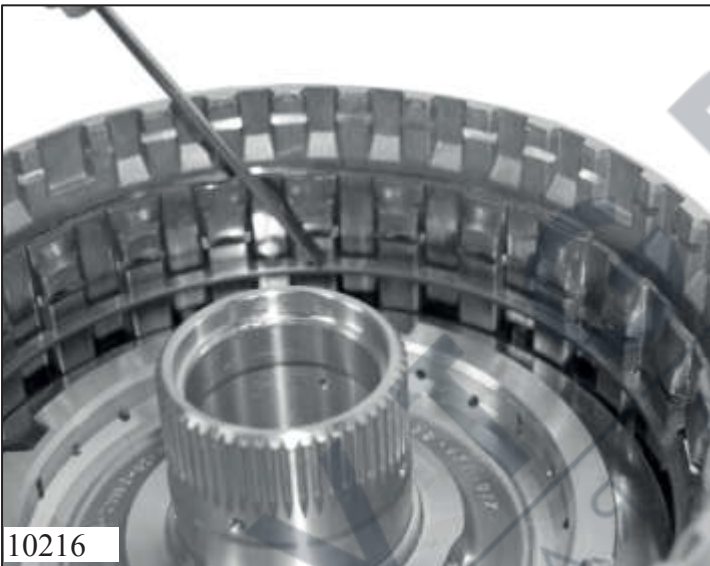

10216

Insert a new snap ring (40.070) into sun shaft.

A clearance of approx. 15 mm must be left from top of snap ring to end disk in clutch E.

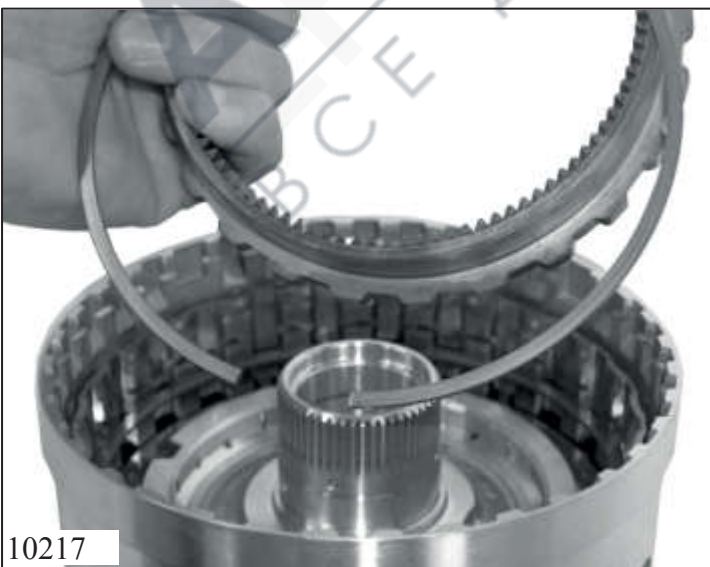

10217

Fit annulus (40.050) in position shown in sun shaft and secure it with a new snap ring (40.030).

Fit needle bearing (40.120) with angle washer (40.100/060) on clutch E.

Fit planetary support 3 (40.100) in annulus.

Secure pot 2 with a new snap ring (40.160/130).

Position snap ring and drive it in using tool AA00.548.688 (see figure).

Take completed unit out of mounting device.



Place pot 1 in supporting fixture 5x46.004.264.

Place output shaft (42.010) in pot 1.



Fit completed pot 3 in pot 1 turning it.



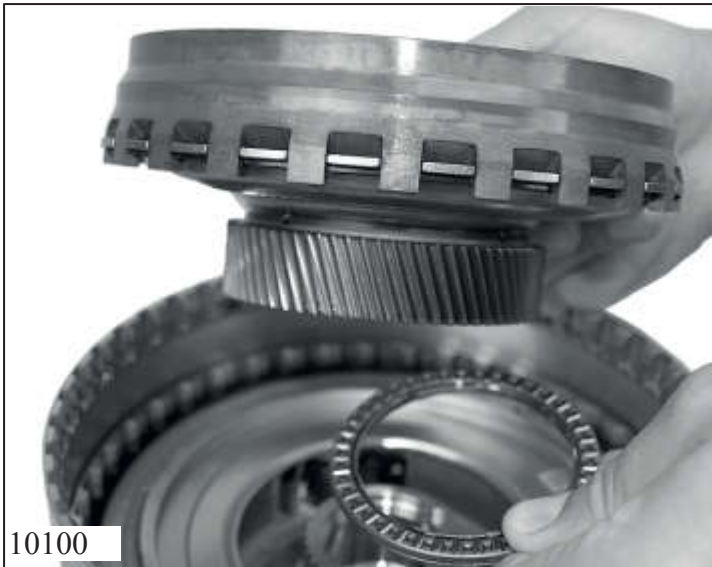

10100

Place needle bearing (40.010) with angle washer on hub of planetary support.

Connect annulus 2 (40.160/120) and sun gear 3 (40.160/110) and secure them with a new snap ring(40.140).

Fit angle washer (40.160/140) in sun gear 3.

Place unit in gearset 3.



10101

Place needle bearing (40.170) with chamfered angle washer on the sun gear.



14014

Raise 5 new rectangular rings (32.080) and 2 new rectangular rings (32.090) onto input shaft (32.030) using tool AA00.381.834.

Insert input shaft into supporting fixture AA00.686.190.

Fit planet carrier 2 (32.010) onto input shaft.

Secure planetary support with a new snap ring (32.050).

Use assembly device 5x46.003.918.

Place oil collection tray (32.020) on planetary support.



Place angle washer (32.060) on planetary support.



Insert drive shaft into tower.

Fit needle bearing (32.010/120) with angle washer (32.010/130) above drive shaft.





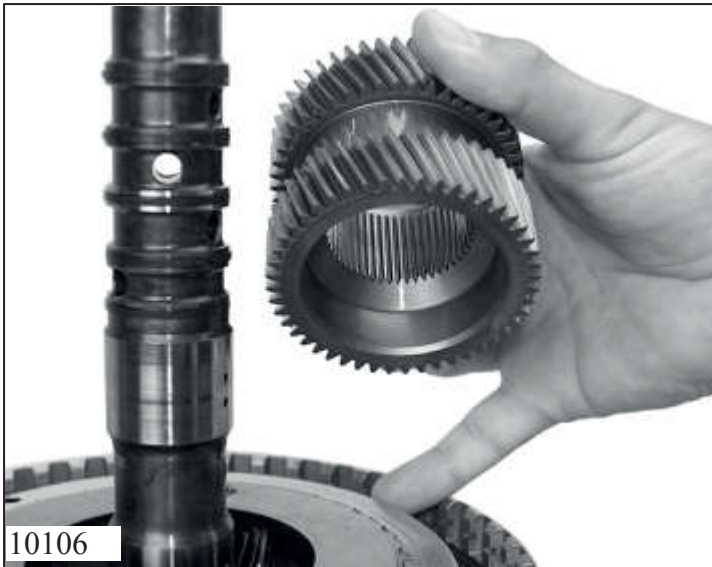

Fit sun gear 1-2 (32.120) (with deep recess at the bottom) in planetary support 2.



Place planetary support (31.010) over sun gear 1-2.

Place oil collection tray (31.030) on planetary support.

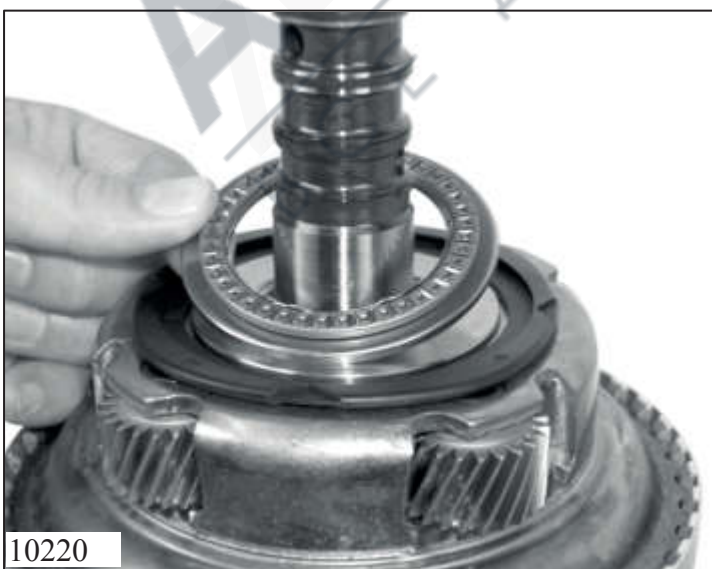

Place needle bearing (02.050) with angle washer on planetary support.

Pull pot 1 upwards.

Secure new snap ring (31.020) using tool AA00.548.688.

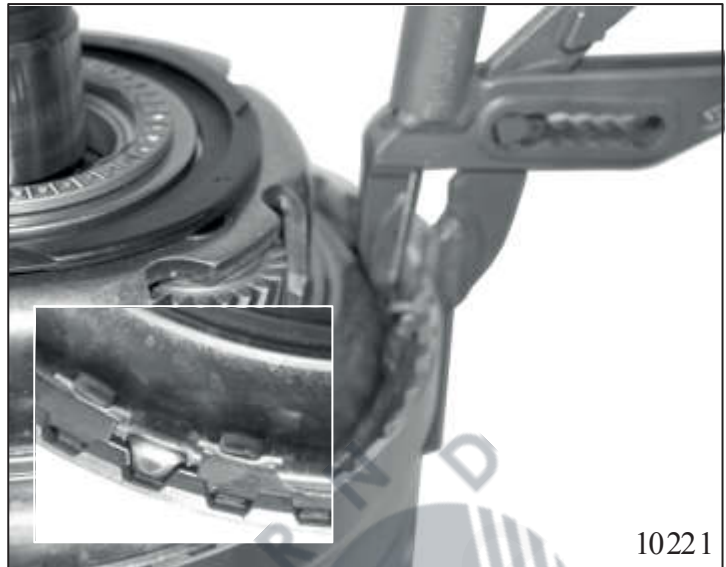

Place annulus (02.070) with caulked angle washer on planetary support.

Insert shim (10.210).



### 3.3.2 Assemble oil supply



Fit 2 new O-rings and new sealing element to pump (10.040).

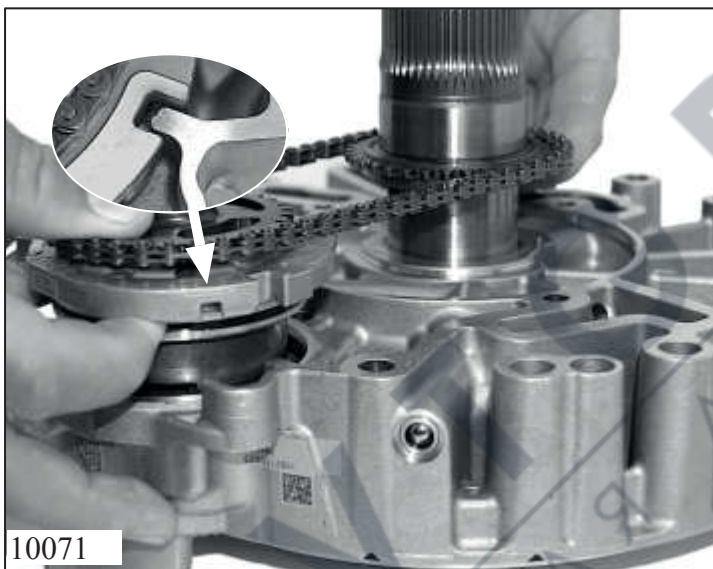

Fit pump with chain (10.060) and chain drive wheel (10.080) in intermediate plate (10.010).



Press pump firmly on intermediate plate with tool 5x46.003.913.

The gap between pump and intermediate plate is approx. 2 mm.

Fit intermediate plate in clamping device AA00.602.553.

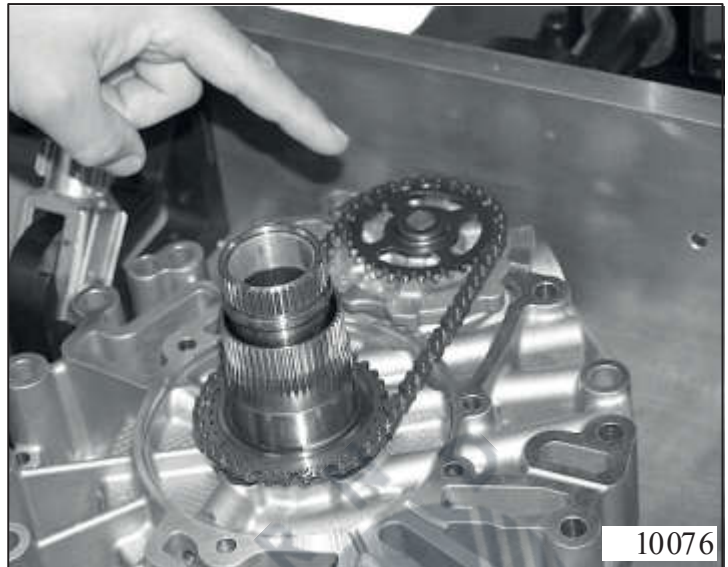

Fit centering plate (10.100) and align it using 14 through boreholes around its circumference.

Place hold-down device on centering plate.

Press centering plate with hold-down device by turning threaded spindle with a tightening torque of 11 Nm.



**NOTICE**

Section 1.3, see screw connection specification

See section 1.5 for tightening torques.

Loosen the locking of the fixture.

Turn unit through 180° and secure it with 5 new screws (10.110).

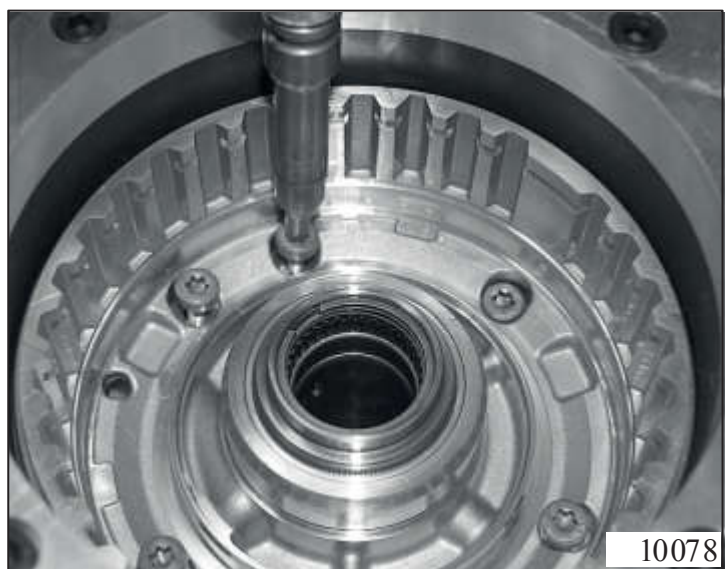

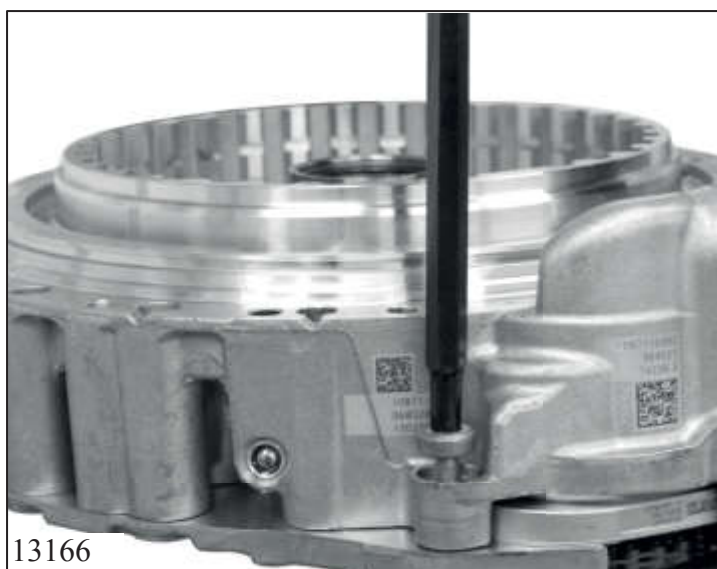

Release tension by turning threaded spindle.

Remove hold-down device.

Remove oil supply.

Turn screw (10.110) into intermediate plate.

(See section 1.5 for tightening torques)



Turn unit over.

Turn hexalobular screw (10.120) into intermediate plate.

(See section 1.5 for tightening torques)

### 3.3.3 Assemble brake A

Fit 2 new lip sealing rings (70.030, 70.050) on piston A (70.010).

Press piston A into oil supply (cylinder A).

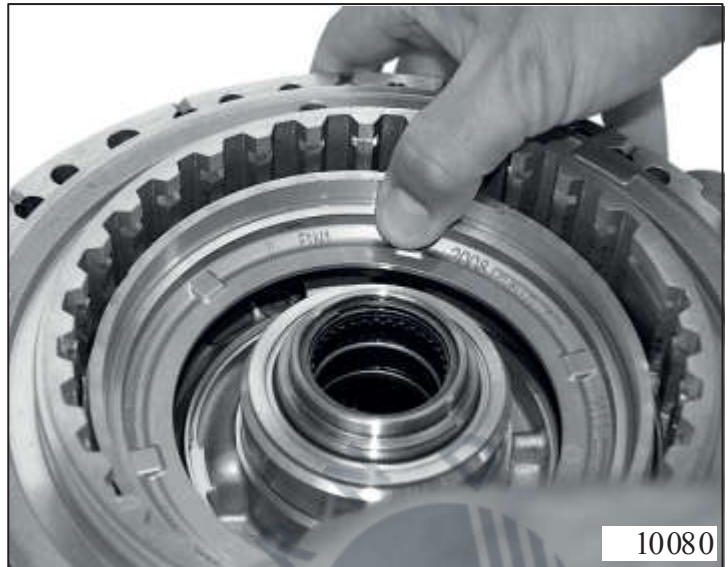

Fit disk spring (70.070) into oil supply (cylinder A).

Press in assembly bar 5x46.001.502 under mandrel press and secure it with split ring (70.080).

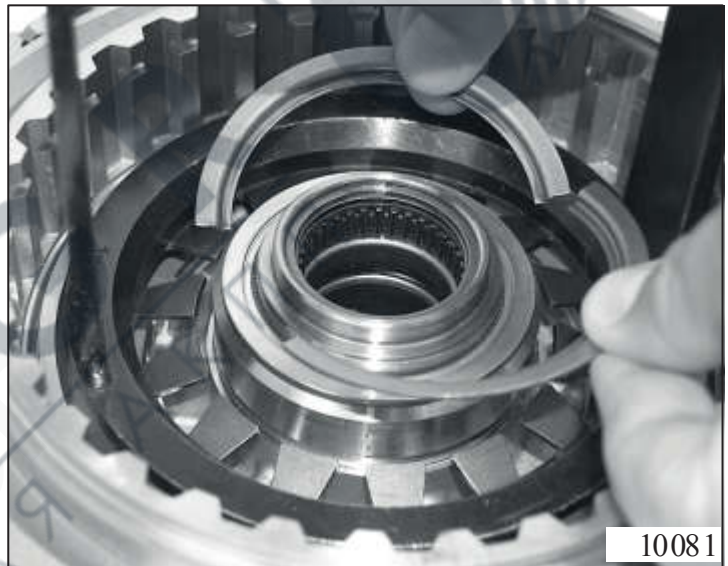

Fit angle washer (70.100) and needle bearing (70.090) into oil supply (cylinder A).



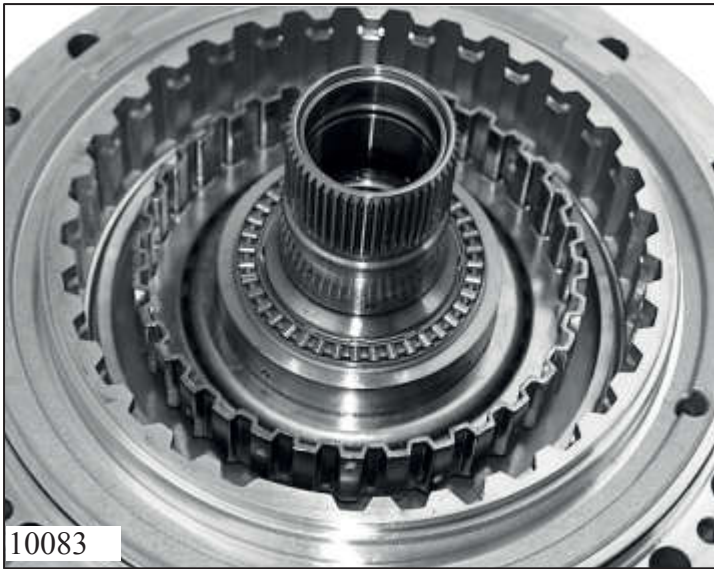

10083

Position axial needle bearing (70.220) on multidisk carrier (70.110).

Fit multidisk carrier into oil supply (cylinder A).

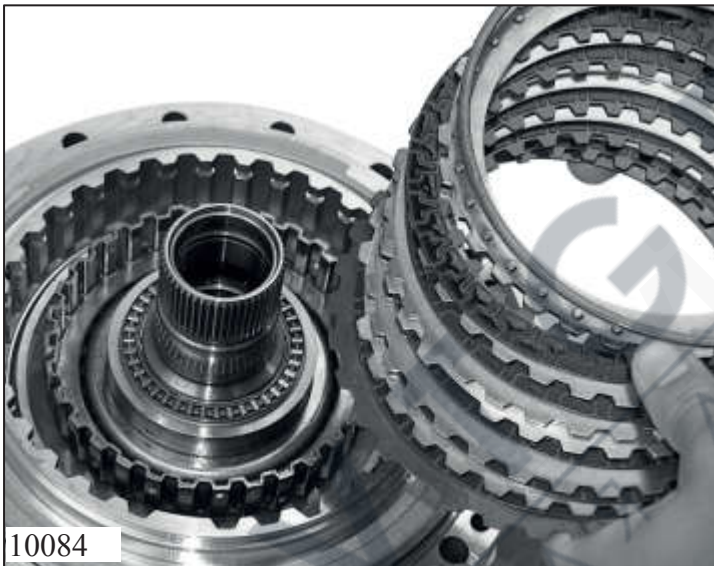

10084

**NOTICE**

Refer to section 1.4.5. Adjustment work

Insert multidisk package.  
Start with a coil spring (70.120), then insert external disks (70.130) and lining disks (70.140) alternately.  
Finally fit an end disk (70.150).

Secure with a snap ring (70.160).

### 3.3.4 Assemble brake B

Fit new O-ring (72.140) on intermediate plate.

Fit piston B (72.100) with a new lip sealing ring (72.110) and new profile seal (72.120) into intermediate plate.



Fit cylinder B (72.130) over piston B into intermediate plate.

Position centering lug of cylinder B in roove in intermediate plate.



Push in cylinder B until it is fully supported.

Piston B must protrude over cylinder B.

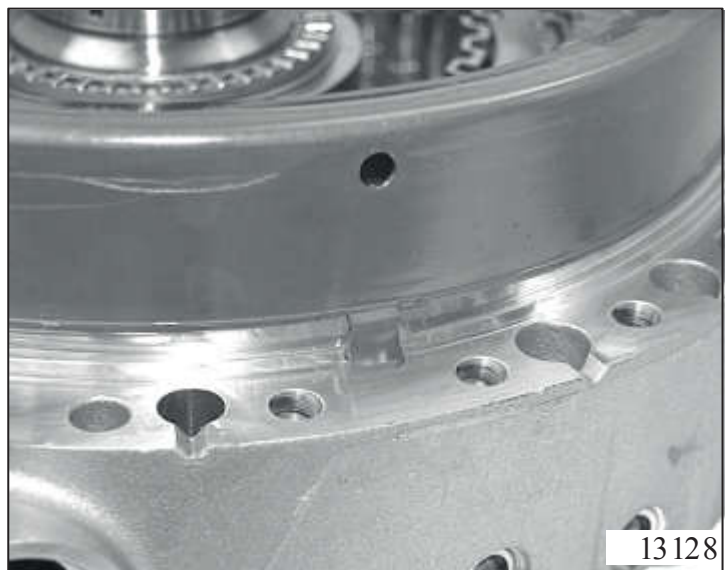



3.4 Install tower and oil supply in transmission  
3.4.1 Install tower

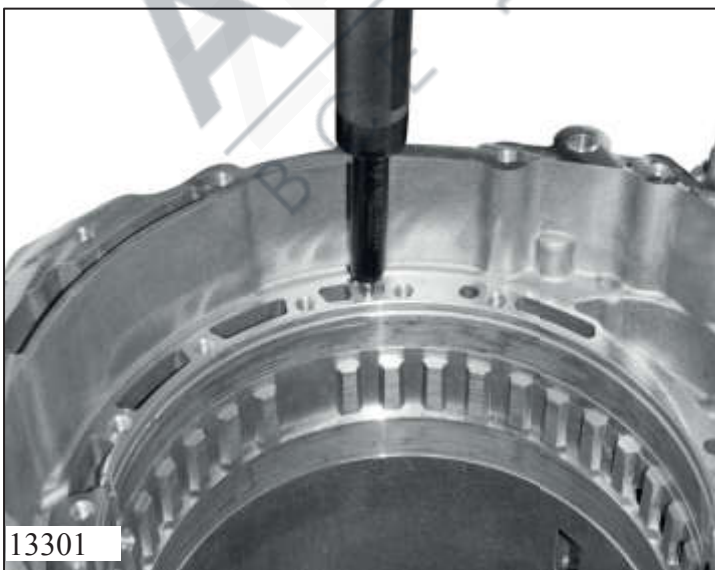
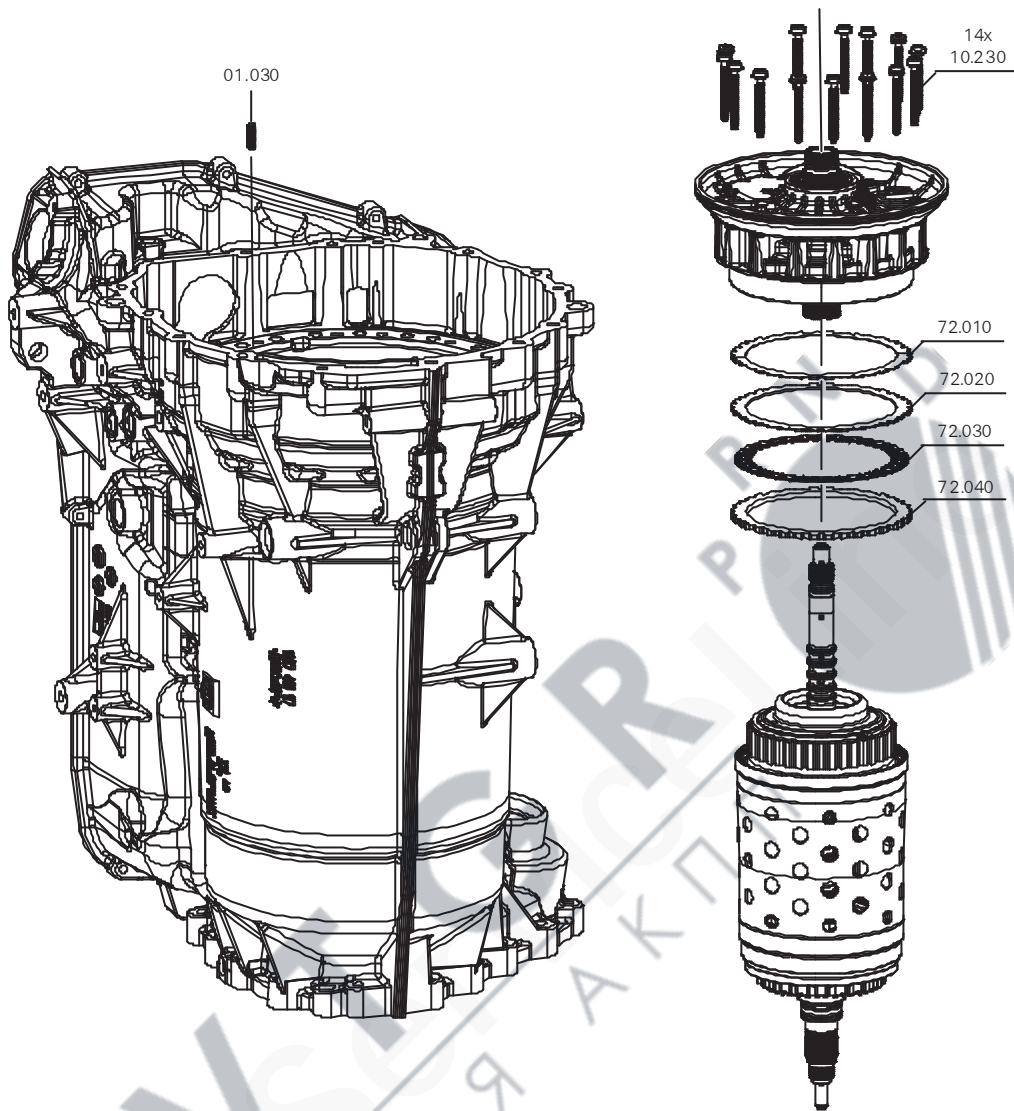

Turn transmission with converter side faces upwards.

*New transmission housing*

Drive cylindrical pin (01.030) into transmission housing using tool AA00.615.414 for oil supply.

Rotate transmission housing by 180°.

Place tool AA00.596.017 on transmission housing and lock it in place.



Place tower lifter 5x46.003.957 on drive shaft and secure it with slide.

Install tower with lifting device into transmission housing.

Remove tower lifter.

Remove tool AA00.596.017.

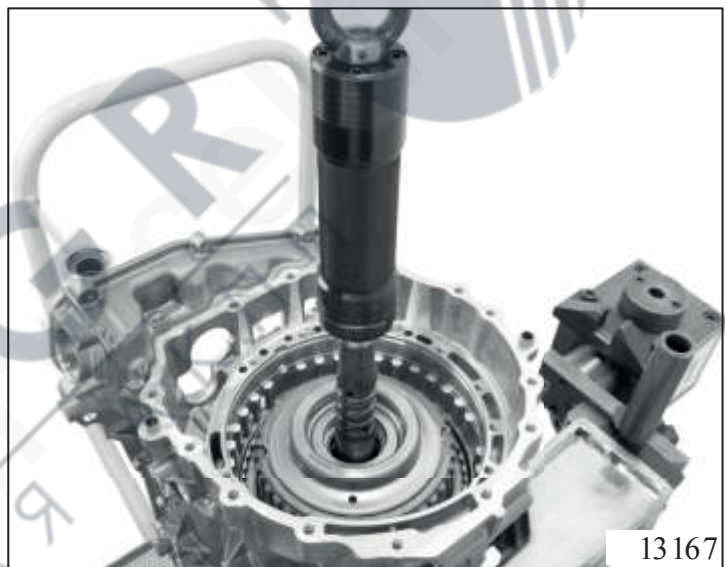

**NOTICE**

Refer to section 1.4.6. Adjustment work

Insert brake B:  
Start with end disk (72.040), then insert lining disks (72.030) and external disks (72.020) alternately.  
Finally fit a coil spring (72.010).

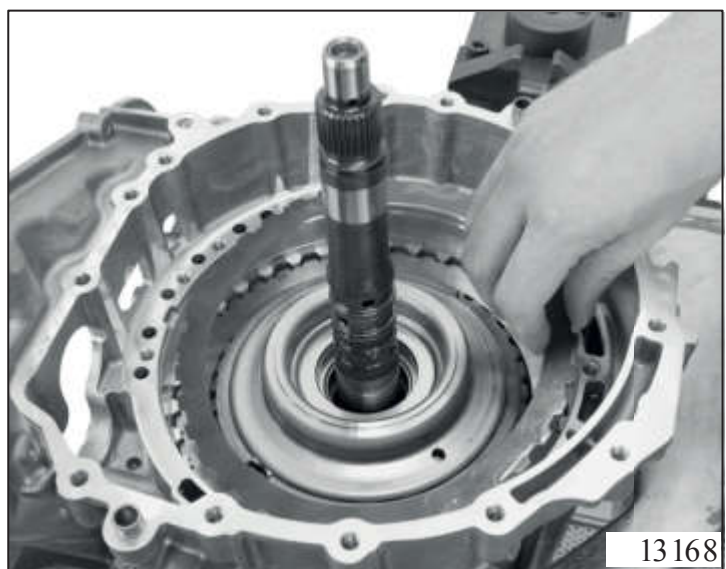

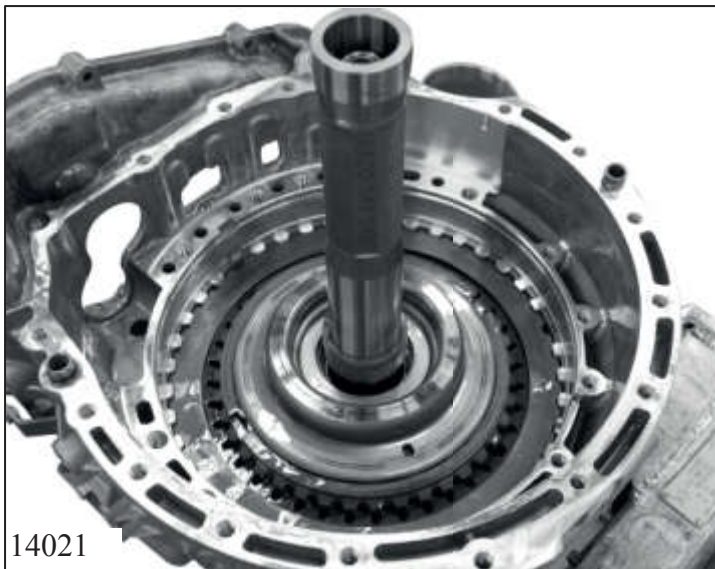

**NOTICE**

The tool shown below should be used to prevent damaging the rectangular rings.

To center rectangular rings, slide tool AA00.549.949 over drive shaft to end position.

Remove tool.

### 3.4.2 Install oil supply

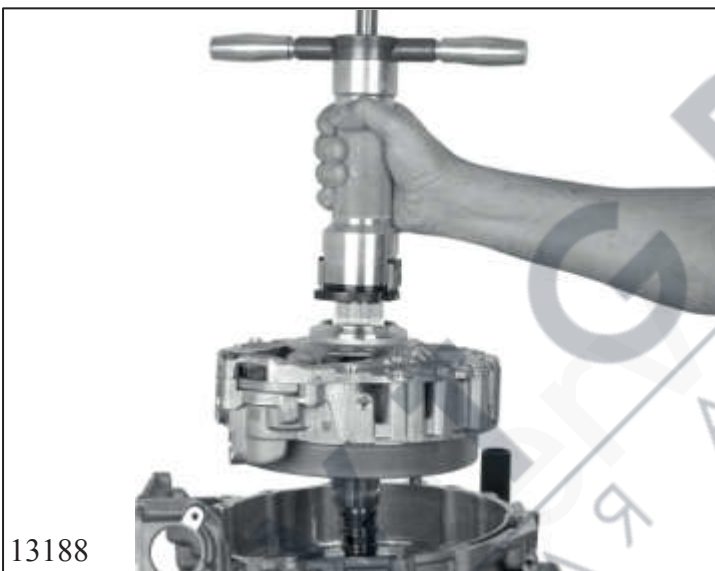

**NOTICE**

Refer to section 1.4.9. Adjustment work

Insert oil supply in transmission housing using lifting tool AA00.549.802 and press it into position.

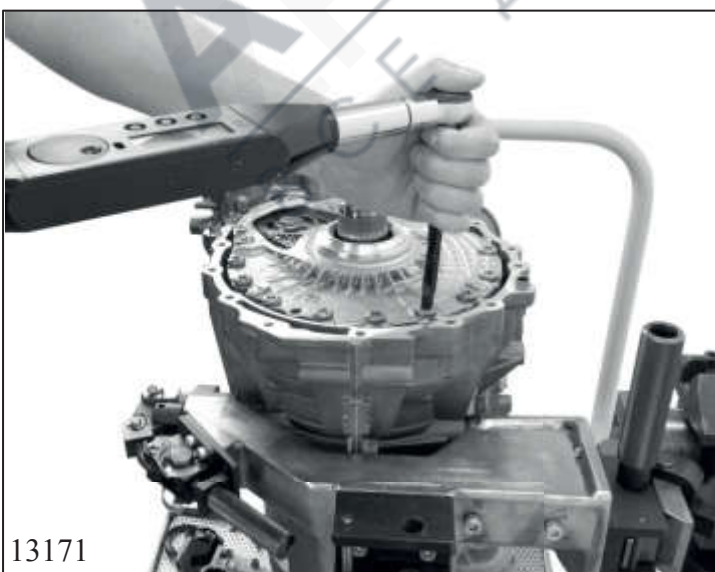

**NOTICE**

Section 1.3, see screw connection specification

See section 1.5 for tightening torques.

Secure oil supply with 14 new screws (10.230).

Secure sealing device AA00.373.240 in position shown using 10 screws and tighten them with a torque of 8.0 Nm ( $\pm 0.8$  Nm).

Press off clutches using a pneumatic gun (see figure).

Remove sealing device.



*Alternative*

Turn transmission housing over so oil pan faces upwards.

Press off clutches using a pneumatic gun (see figure).

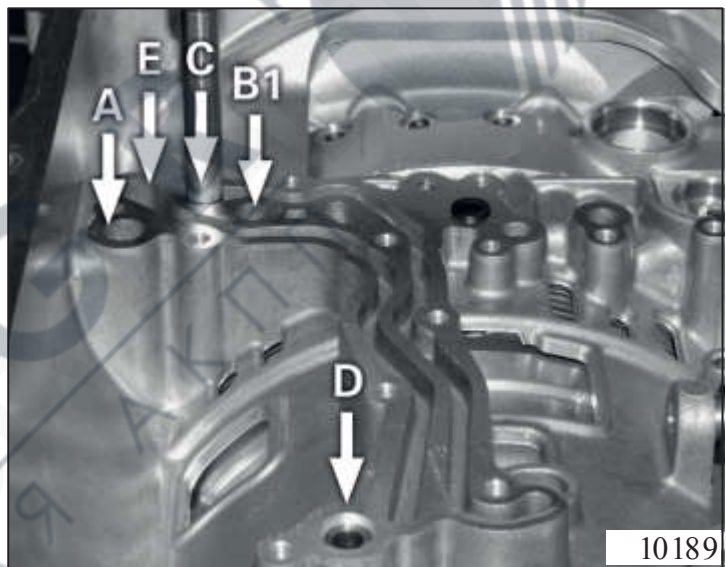

### 3.5 Assemble mechatronic unit and oil pan

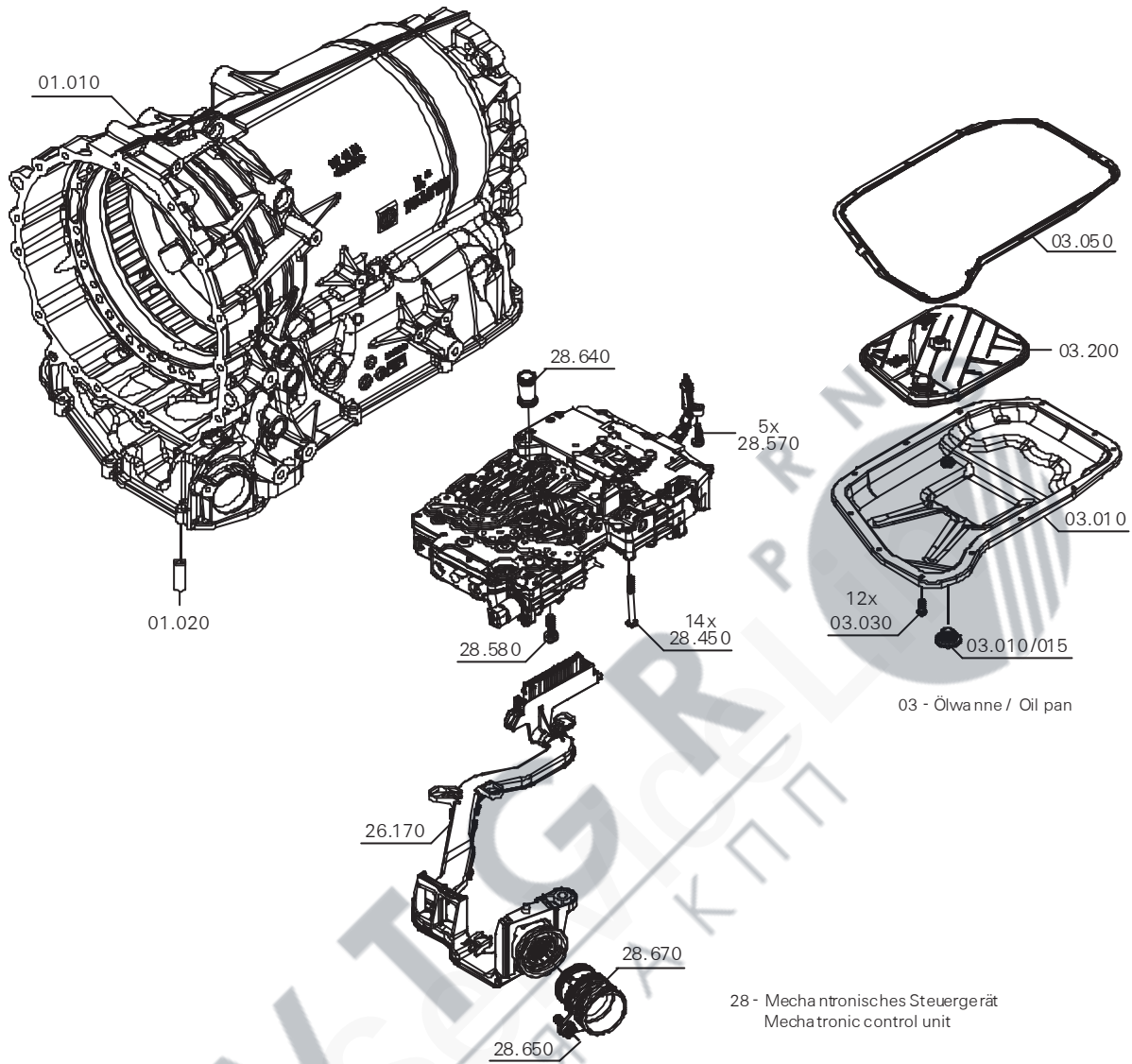

#### 3.5.1 Install mechatronic unit

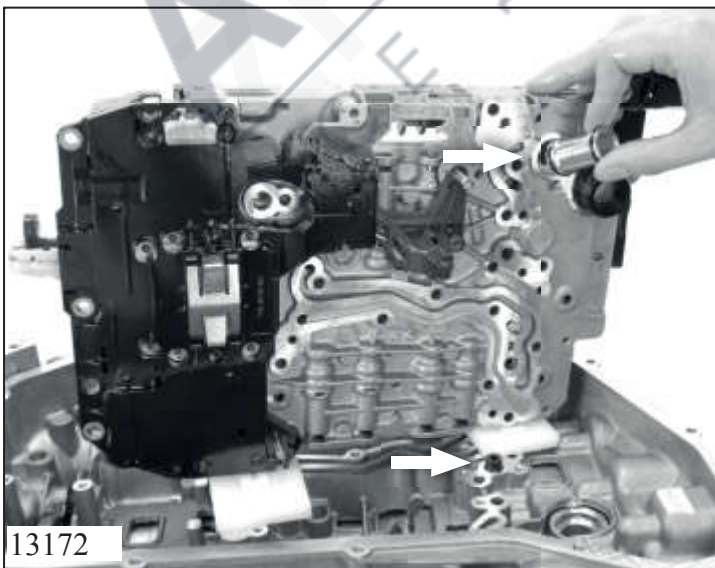

Turn transmission with control unit side at top.

Fit new sealing sleeve (01.020) in transmission housing (01.010).

Insert a new pressure tube (28.640) into mechatronic unit.

## Manual gearshift

Place tool AA00.603.510 on mechatronic unit.

Position positioning switch and selector lever with tool.

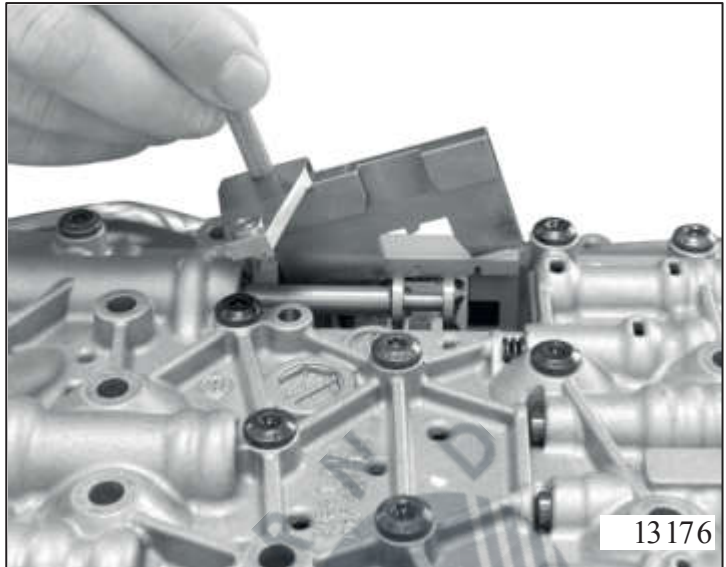

Set selector shaft to position "N".

Position mechatronic unit.

Attach catch disk to mechatronic unit.

Press mechatronic unit against transmission housing to produce a positive connection and remove tool.

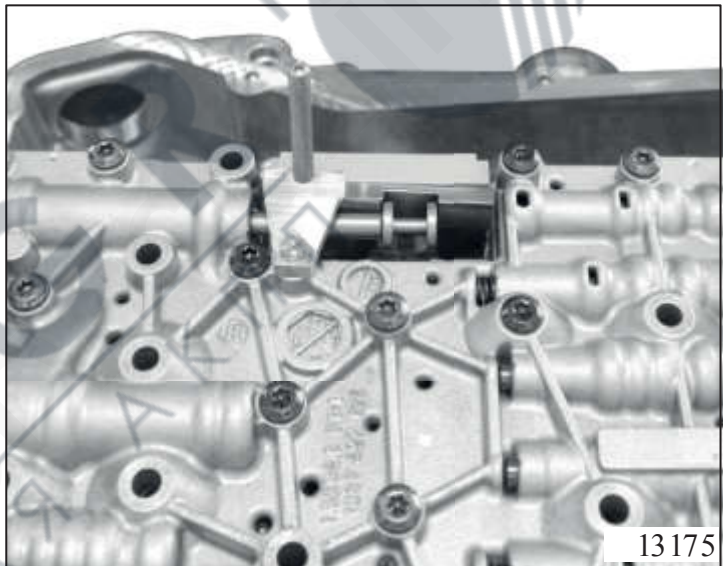

### NOTICE

Section 1.3, see screw connection specification

See section 1.5 for tightening torques.

Secure mechatronic unit with 14 new screws (28.450).

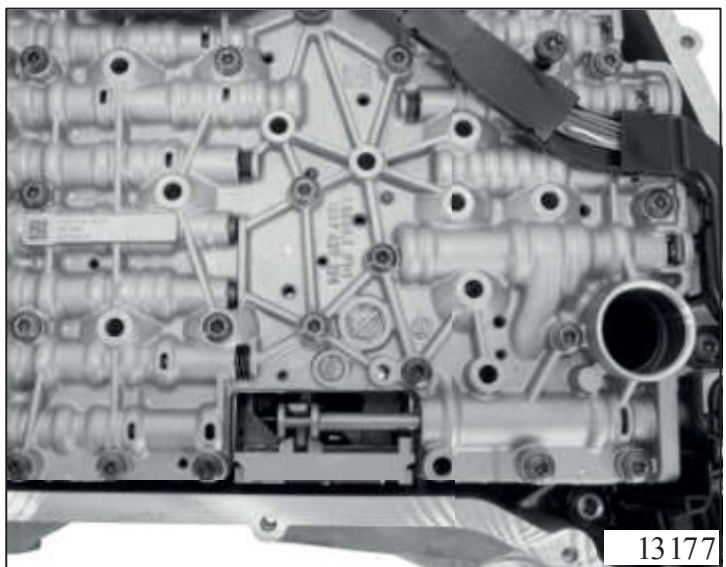

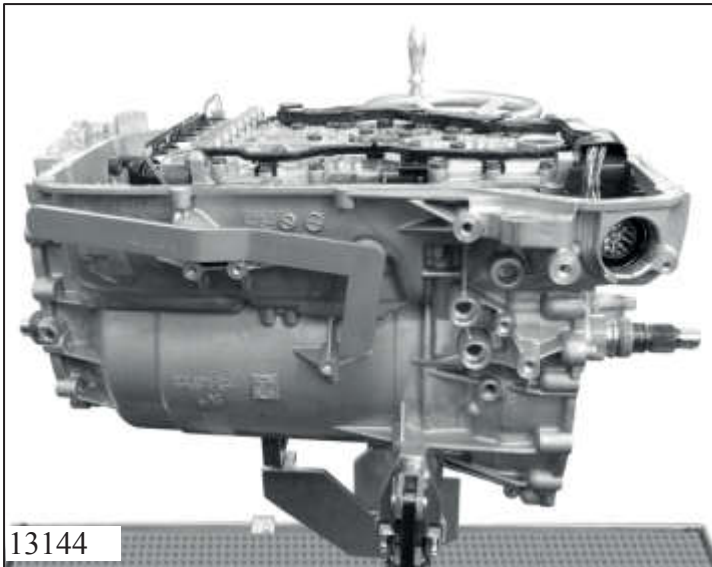

**NOTICE**

Section 1.3, see screw connection specification

See section 1.5 for tightening torques.

Position mechatronic unit.  
Attach parking washer to mechatronic unit. Press mechatronic unit against transmission housing to produce a positive connection. Secure mechatronic unit with 14 new screws (28.450). Remove selector shaft holding tool.

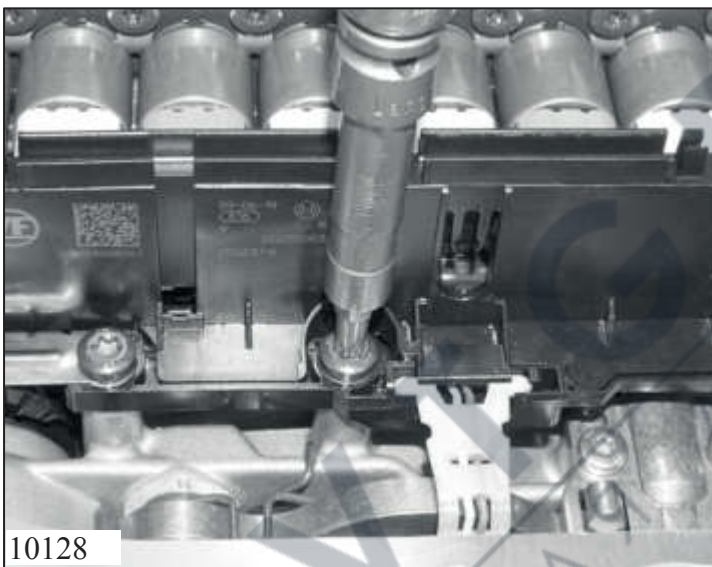

Screw in 3 screws (28.570) on mechatronic unit.

*2 screws on a transmission with oil reservoir:*

(See section 1.5 for tightening torques)

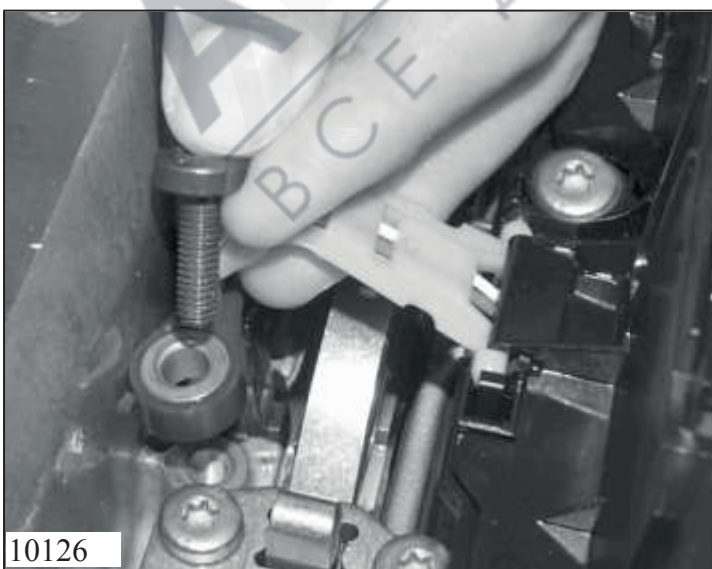

Fit speed sensor in groove in transmission housing and secure it with screw (28.570).

(See section 1.5 for tightening torques)

### *Transmission with oil reservoir*

Fit a new O-ring in delivery connection from oil volume accu.

Insert oil volume accu in transmission housing.  
Screw in 1 screw (28.450) and 2 screws (28.570) for oil volume accu.

Connect cable connector from oil volume accu.

(See section 1.5 for tightening torques)

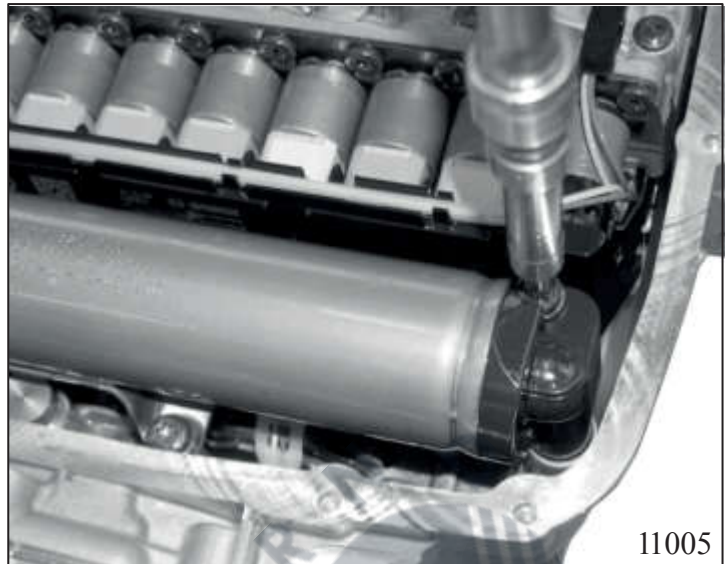

Secure cable loom (26.170) to transmission housing with screw (28.580).

(See section 1.5 for tightening torques)

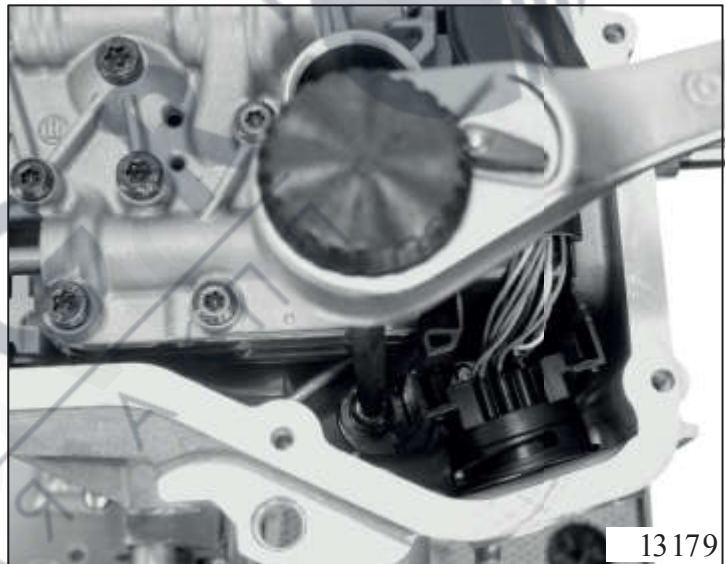

Fit a new guide sleeve (28.670) using tool AA00.615.807 and turn it clockwise as far as possible.

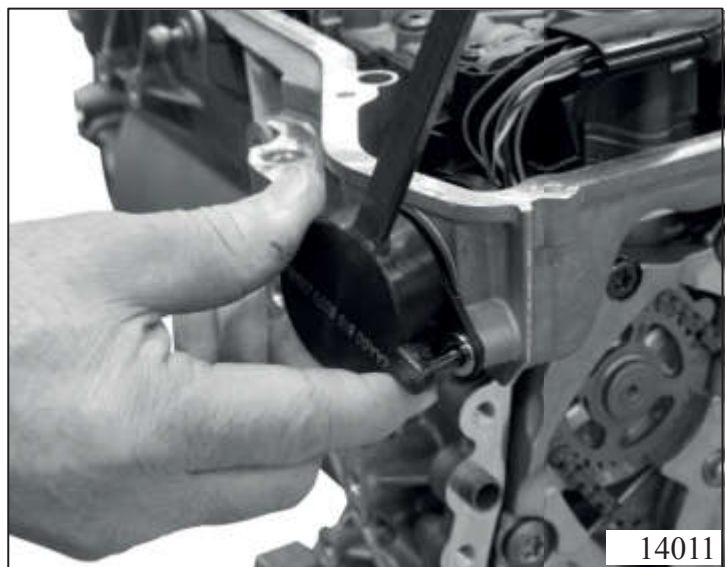



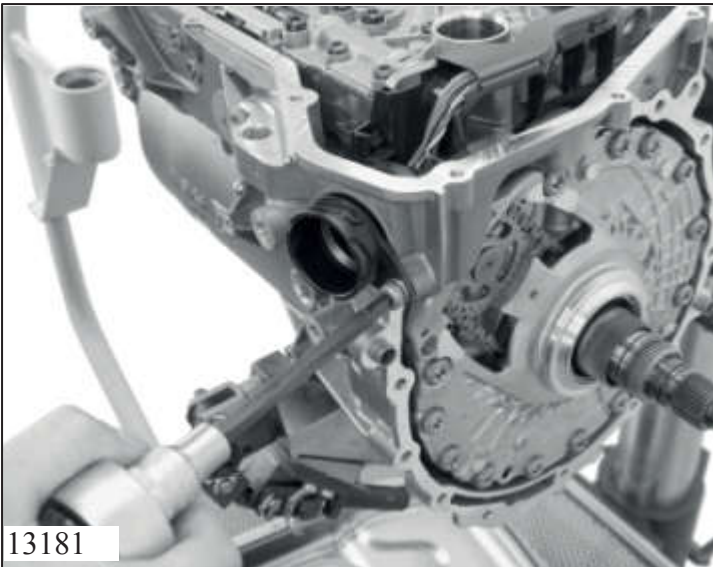

Secure guide sleeve with screw (28.650).

(See section 1.5 for tightening torques)

13181

### 3.5.2 Install oil pan

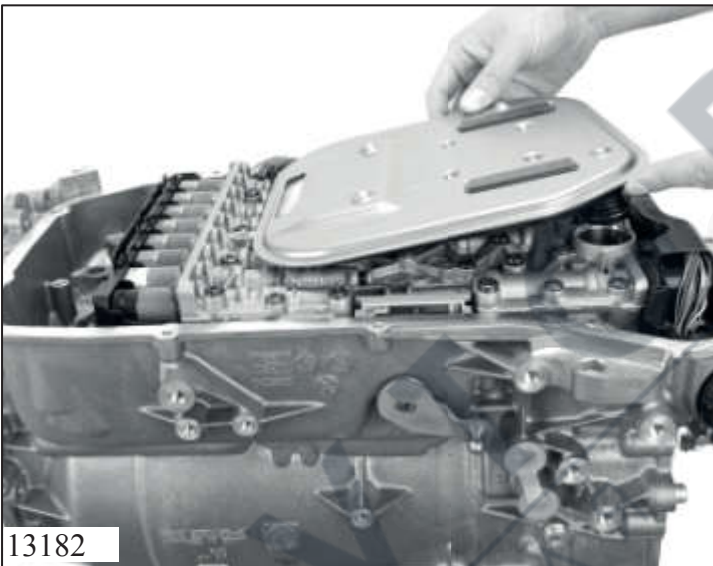

Fit oil filter (03.200) into mechatronic unit.

13182

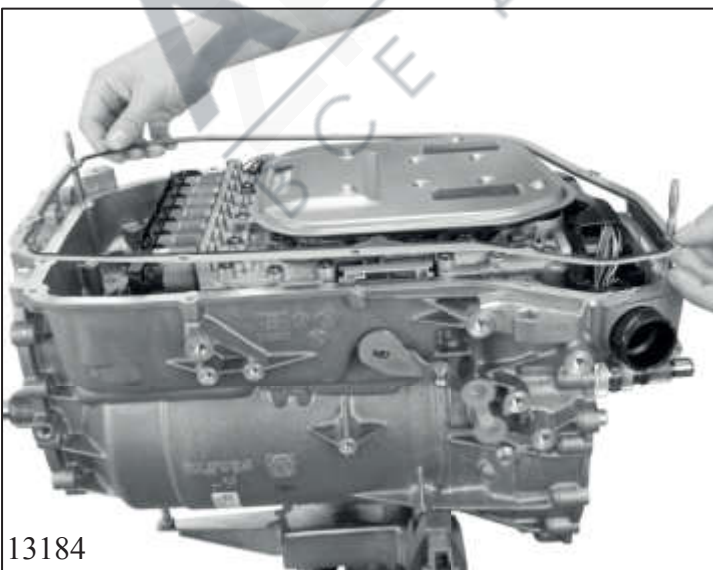

Fit securing pins 5x46.001.521 in transmission housing.

Position seal (03.050) over fixing pins on sealing surface of transmission housing.

13184

**NOTICE**

Section 1.3, see screw connection specification

See section 1.5 for tightening torques.

Place oil pan (03.010) over fixing pins.

Tighten 10 new torx screws (03.030) by hand.

Pull out fixing pins.

Tighten 2 new Torx screws (03.030) by hand in the fixing boreholes.



Screw oil drain screw (03.010/015) into oil pan.

(See section 1.5 for tightening torques)



### 3.6 Complete and install converter housing

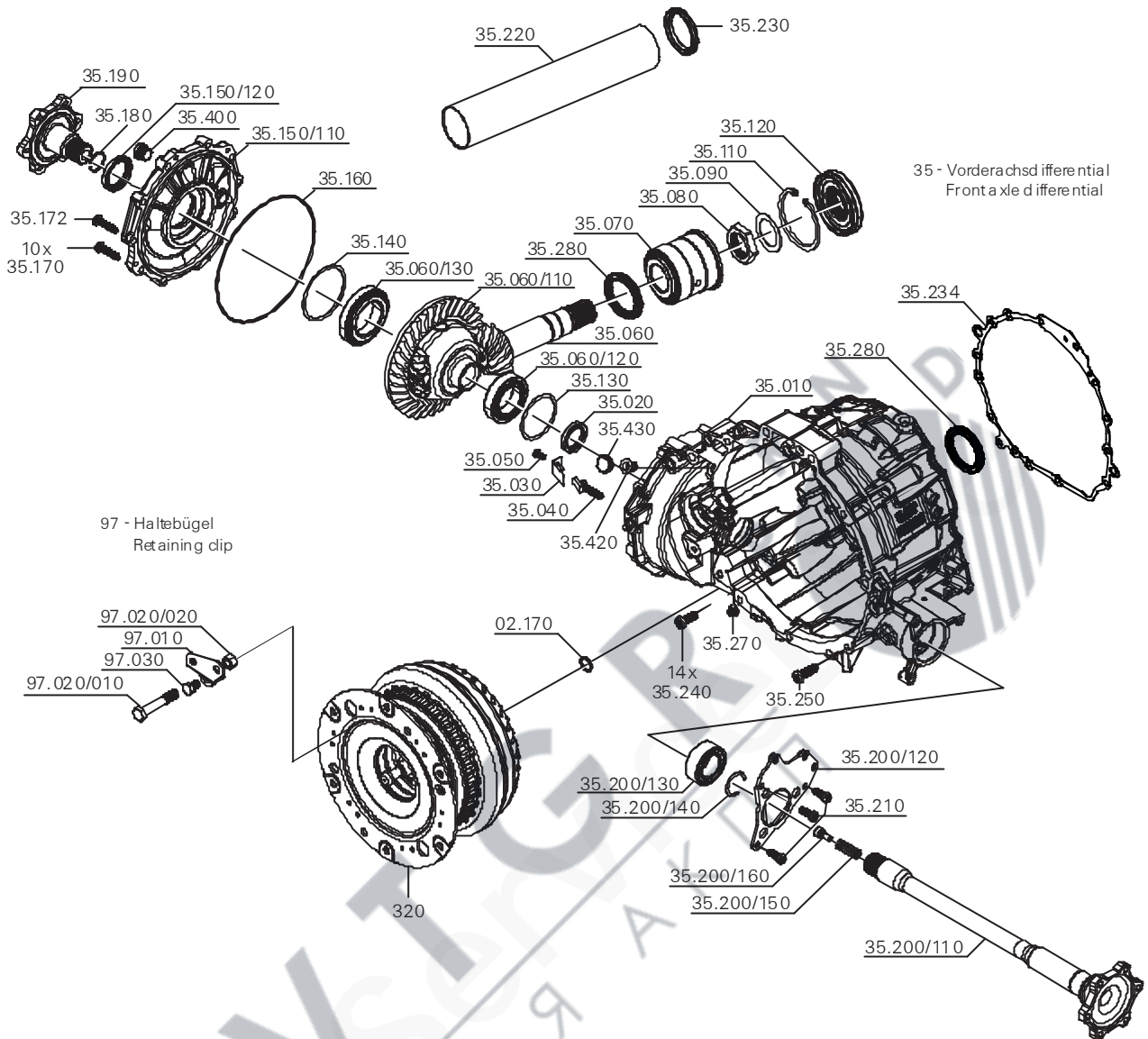

#### 3.6.1 Complete differential cover

Assemble small tapered roller bearing (35.060/120) with press-on device 5x46.002.218 using mandrel press on crown gear (35.060/110).

Turn over crown gear.

Assemble small tapered roller bearing (35.060/130) with press-on device 5x46.002.218 using mandrel press on crown gear (35.060/110).



### 3.6.2 Complete and install pinion shaft

Refer to Section 1.4.8.3 adjustment work

Place shim (35.090) on pinion shaft (35.060).

Fit combination bearing (35.070) with collar facing upwards.



Press pinion shaft into combination bearing using mandrel press.



Insert pinion shaft into device AA00.561.260.





09141

Turn a new lock nut (35.080) by hand on to pinion shaft to form a positive connection and block it using hold-down device AA00.561.262.

Tighten pinion shaft using socket wrench AA00.561.169, reducer section and torque wrench to final torque.

Turn for left-handed thread clockwise and right-handed thread counter-clockwise.

(See section 1.5 for tightening torques)

### 3.6.3 Complete converter housing

1. Screw oil drain sealing screw (35.270) into converter housing (35.010).
2. Place converter housing into holding device 5x46.003.687.

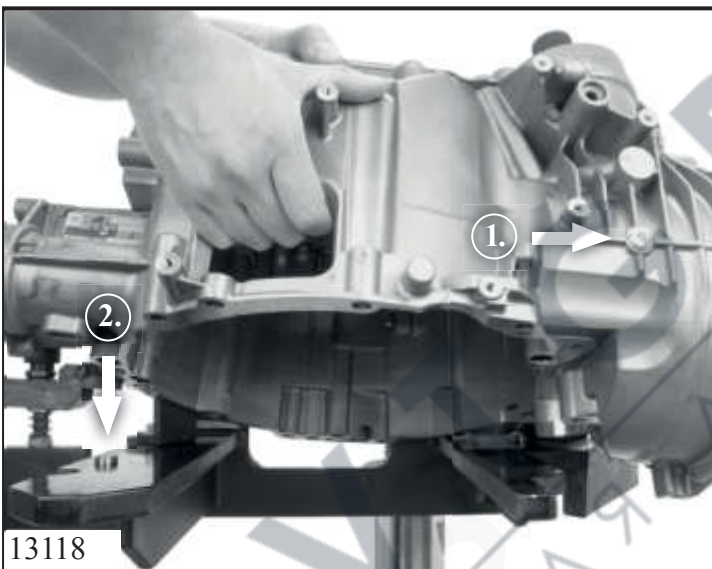

13118

<p><b>⚠ CAUTION</b></p> <p><b>Danger of burns</b> ⇒ Wear safety gloves</p>
--------------------------------------------------------------------------------

Heat converter housing on bearing seat of the pinion shaft with a hot air blower.

Fit pinion shaft.

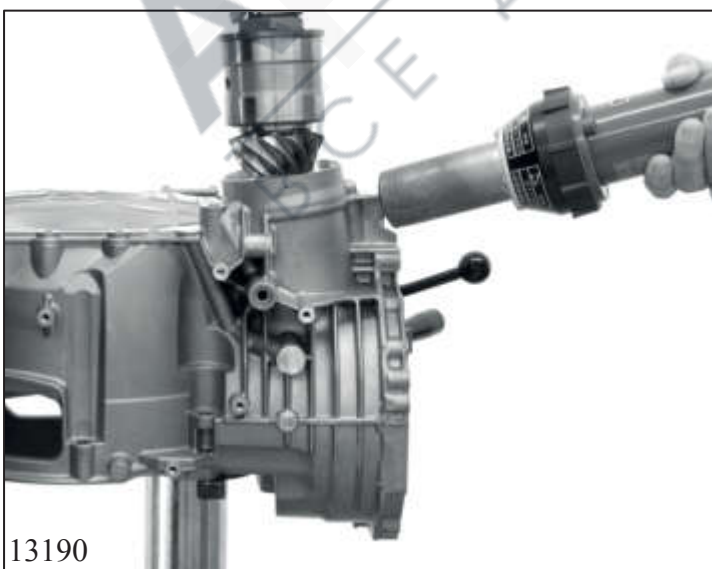

13190

Secure pinion shaft with a snap ring (35.110).

Fit snap ring with phase facing upwards.

Position pinion shaft with a sand hammer.

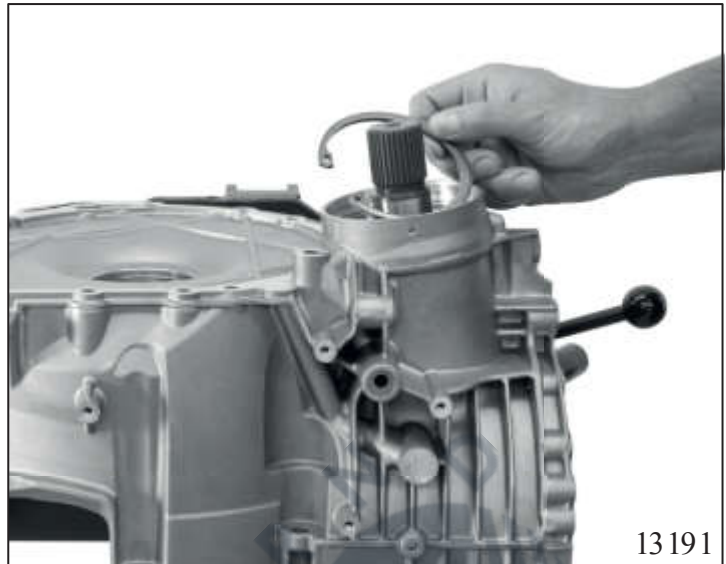

Place insertion tool on plug-in tooting on pini on shaft.

Place shaft sealing ring ring (35.120) in tool AA00.679.163 and drive it into converter housing.

Remove insertion tool.

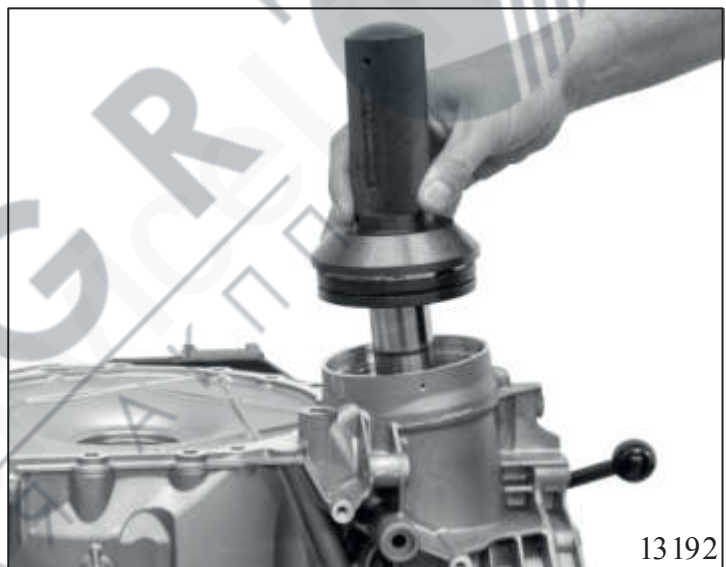

Turn device with differential opening is at the top.

Insert a new shaft sealing ring (35.020) using tool 5x46.004.262.



### 3.6.4 Install differential in converter housing

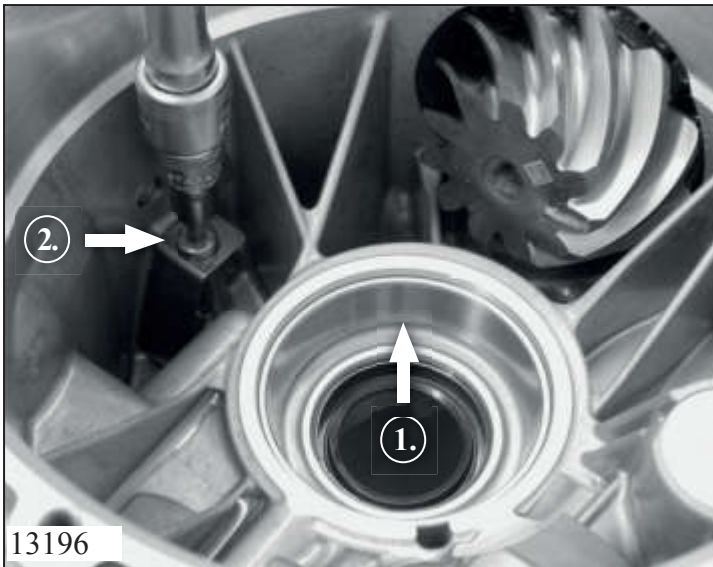

Refer to Section 1.4.8.4 adjustment work  
See section 1.5 for tightening torques.

1. Fit shim (35.130) and bearing shell (35.060/120) into converter housing.
2. Fit magnet (35.040) into hold-down device (35.030) and secure it with torx screw (35.050).



Place differential cover (35.150/110) into press-in device AA00.578.639.

Fit shaft sealing ring (35.150/120) into press-in tool and press it into differential cover.

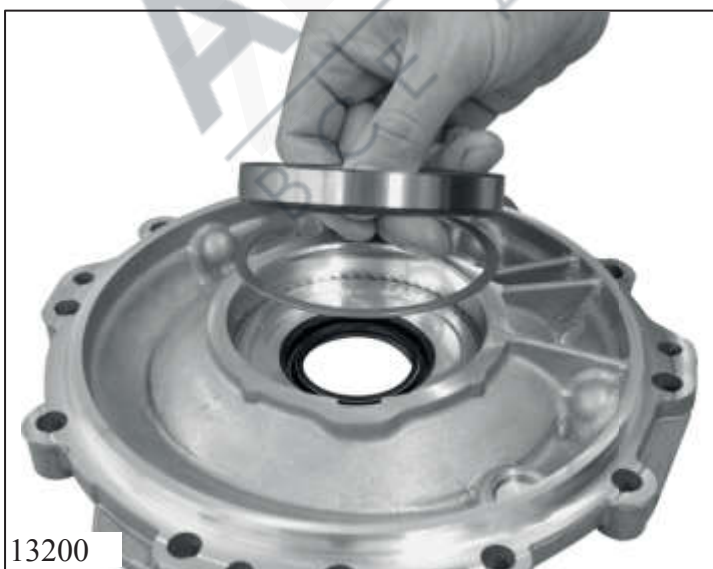

Refer to Section 1.4.8.5 adjustment work

Fit shim (35.140) and bearing shell (35.060/130) into differential cover.

Fit round seal (35.160) on to differential cover.

Insert differential into converter housing.

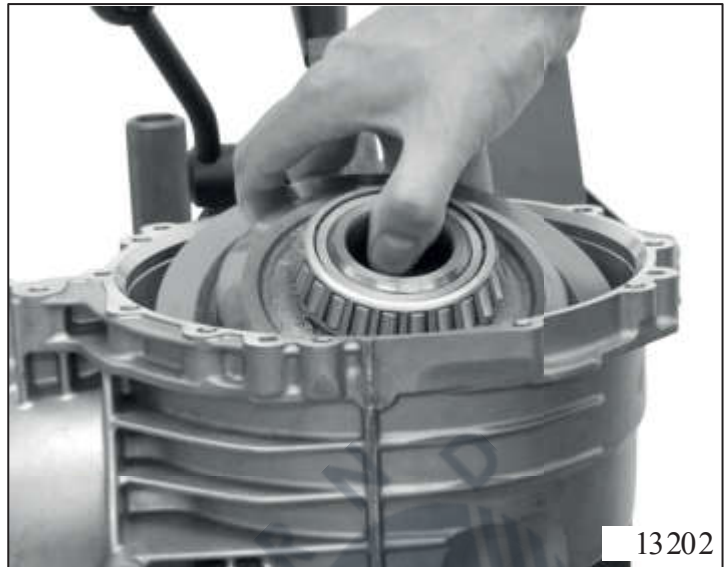

**NOTICE**

Section 1.3, see screw connection specification

See section 1.5 for tightening torques.

Hold bearing shell with your hand as you insert differential cover.

Position differential cover and secure it with 10 torx screws (35.170) and 1 torx screw (35.172).

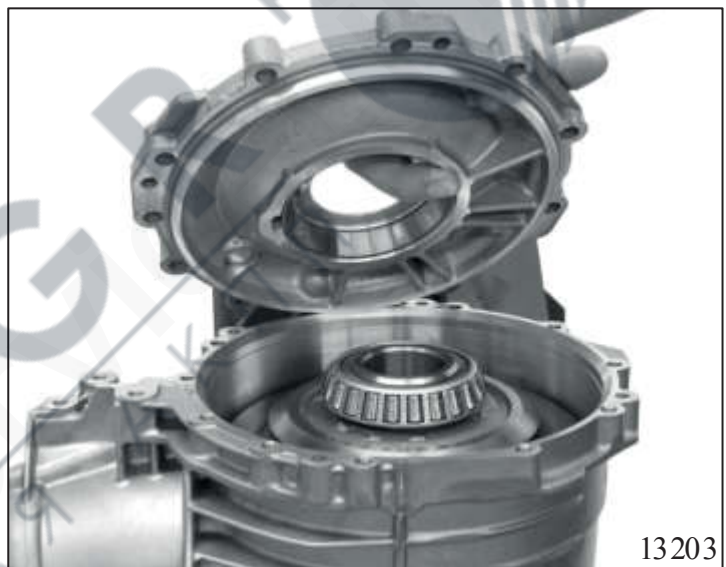

Fit new snap ring (35.180) on output flange (35.190).

Drive in output flange.

Tighten sealing screw (35.400).

(See section 1.5 for tightening torques)





### 3.6.5 Pre-assemble flanged shaft

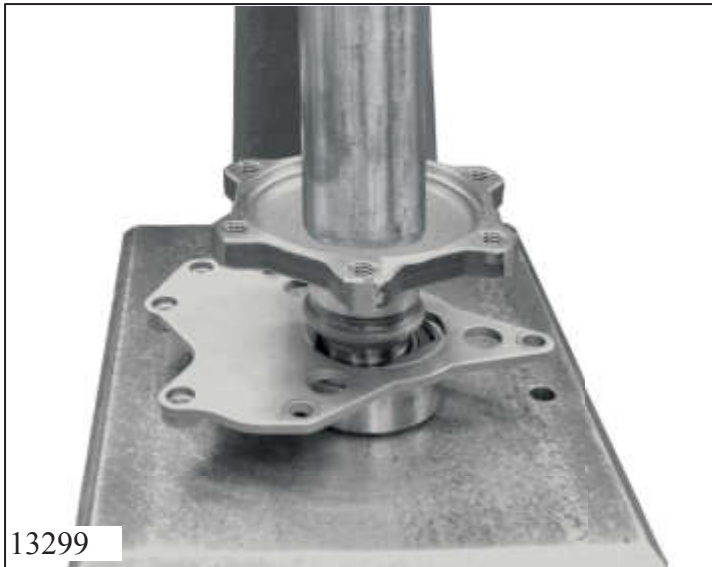

Snap cover (35.200/120) (with welded nuts facing upwards) over flanged shaft (35.200/110).

Fit ball bearing (35.200/130).

Press in using mandrel press with a suitable tool.

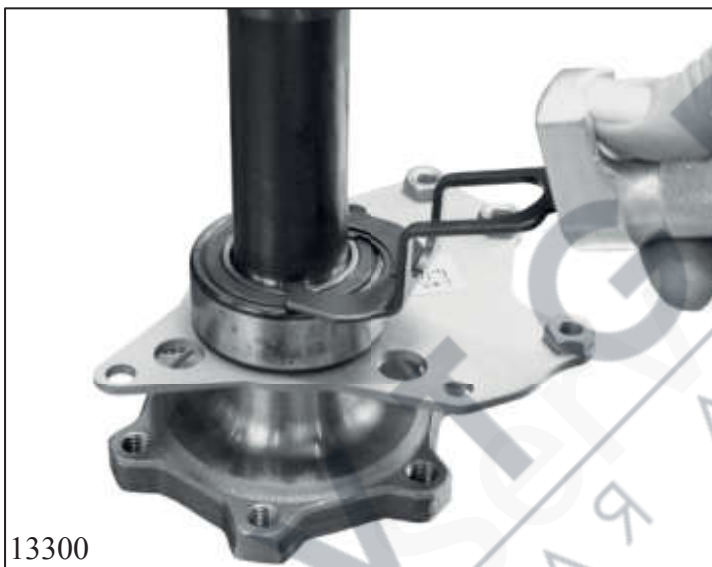

Secure ball bearing with a half-moon ring (35.200/140) using tool 5x46.002.627.



Position spring and tappet in flanged shaft borehole and drive them in carefully using a sand hammer.

### 3.6.6 Install converter housing on transmission housing

Turn transmission with converter housing side is at the top

Fit protective tube (35.220) with new sealing ring (35.230) in transmission housing.

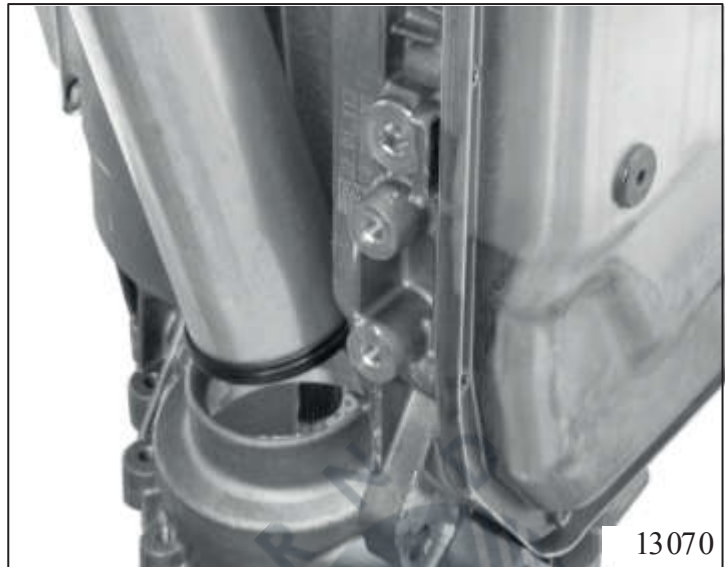

1. Fit a new sealing ring (01.060) in transmission housing.
2. Place new seal (35.234) on sealing surface of transmission housing over both bushes.

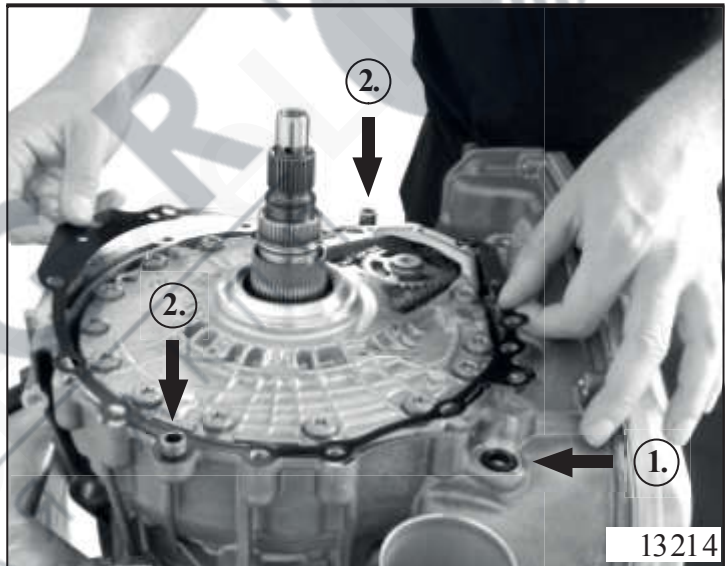

Place converter housing on transmission housing and align it.

Insert 14 new screws (35.240) into interior of converter housing.

(See section 1.5 for tightening torques)



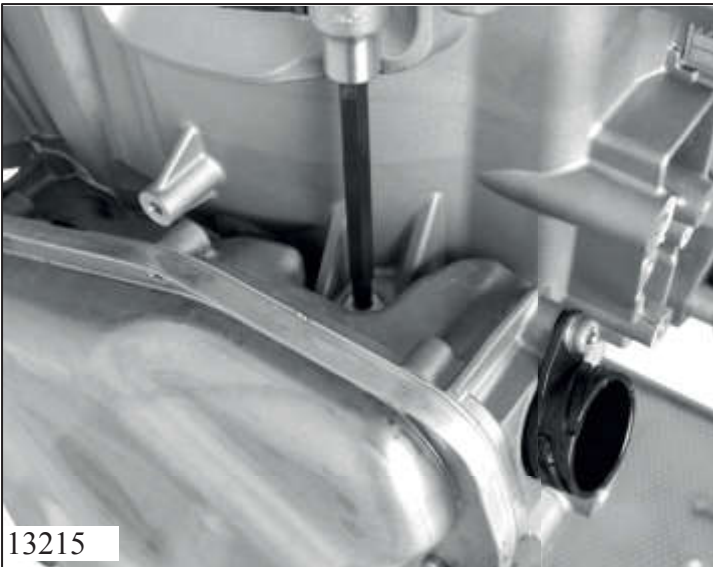

13215

**NOTICE**

Section 1.3, see screw connection specification

Insert 1 new screw (35.250) outside converter housing.

**3.6.7 Install converter and flanged shaft**

Drive shaft sealing ring ring (35.280) into converter housing using tool AA00.613.946.



13223

Fit new O-ring (02.170) on drive shaft.

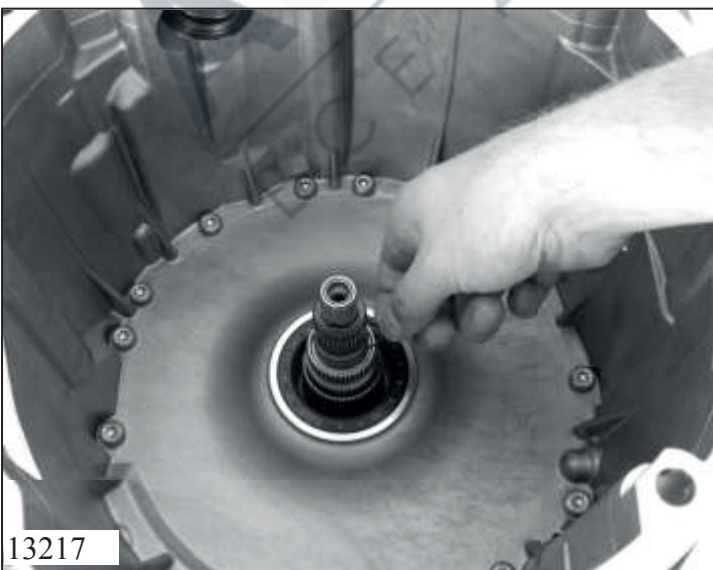

13217

**⚠ WARNING**

**RISK OF ACCIDENT!** The lifting and moving of heavy parts without lifting equipment can lead to damage to health and severe injuries.

⇒ Use a crane or similar lifting equipment.

Fit converter (22.320) with converter lifter 5X46.001.856 and crane in transmission housing.

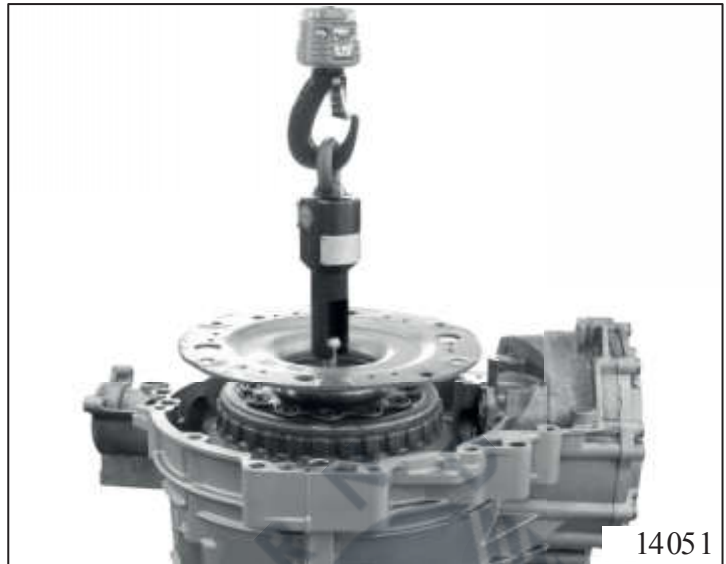

Turn transmission with converter is at the top.

Secure converter retaining bracket (97.010) using screw (97.030) and secure 1 screw with hexagonal nut (97.020) to converter and transmission housing.

(See section 1.5 for tightening torques)

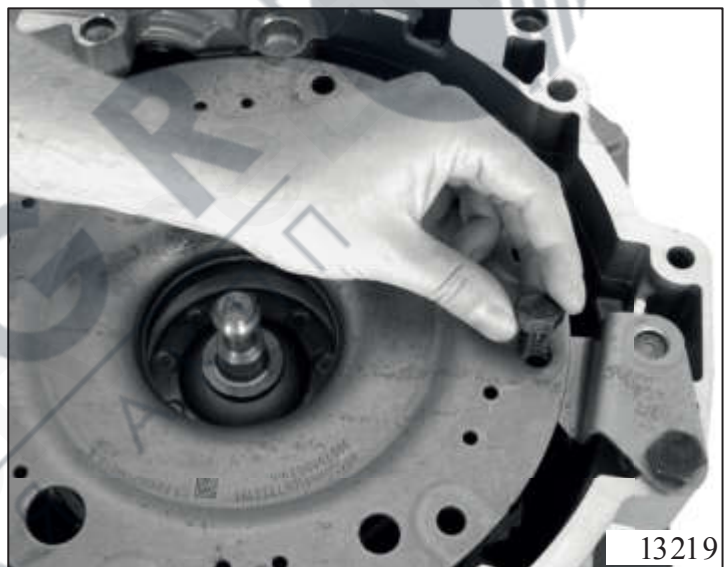

Place flanged shaft in the converter housing and secure it with 3 new torx screws (35.210).

(See section 1.5 for tightening torques)

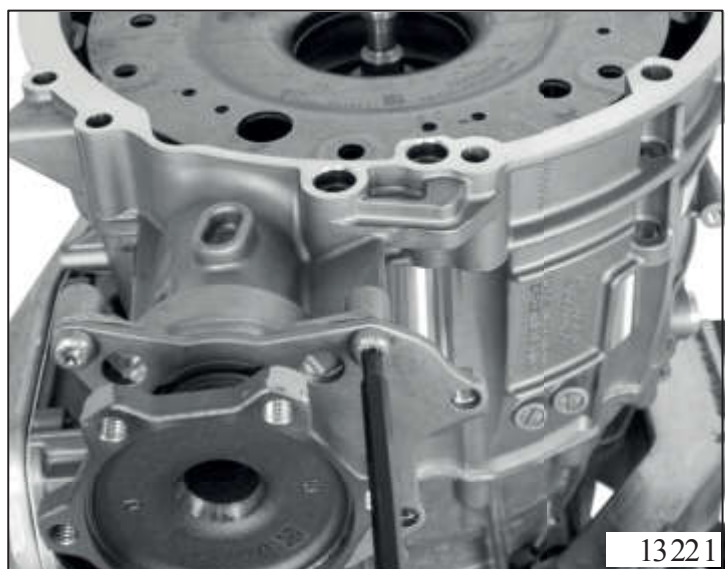



Drive vent tube (35.420) flush into converter housing using tool 5x46.003.018.

Fit vent cover (35.430) into vent tube.

13302





### 3.7 Assemble front axle output

37 - Vorderachsabtrieb / Front axle output

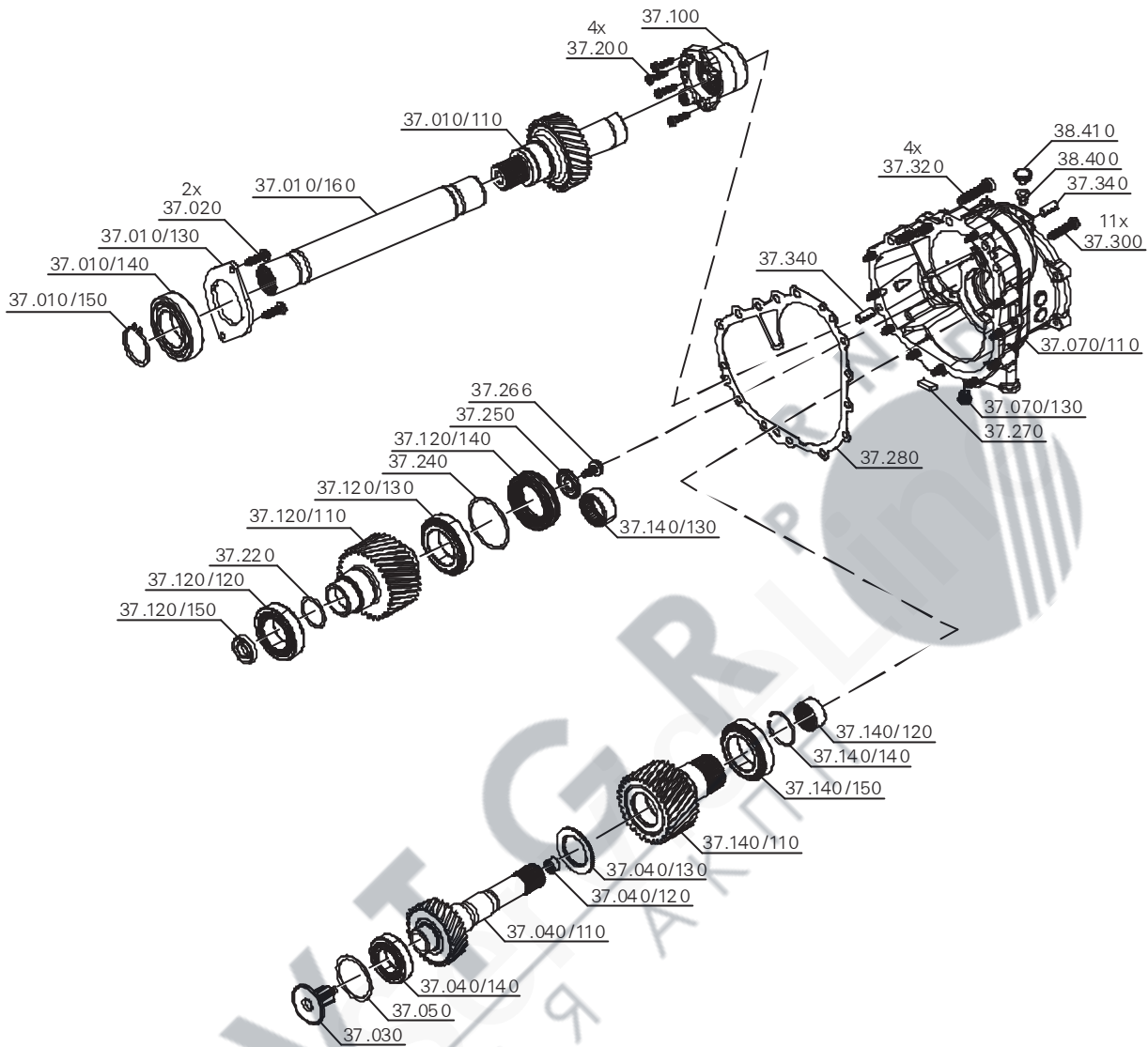

#### 3.7.1 Complete intermediate housing

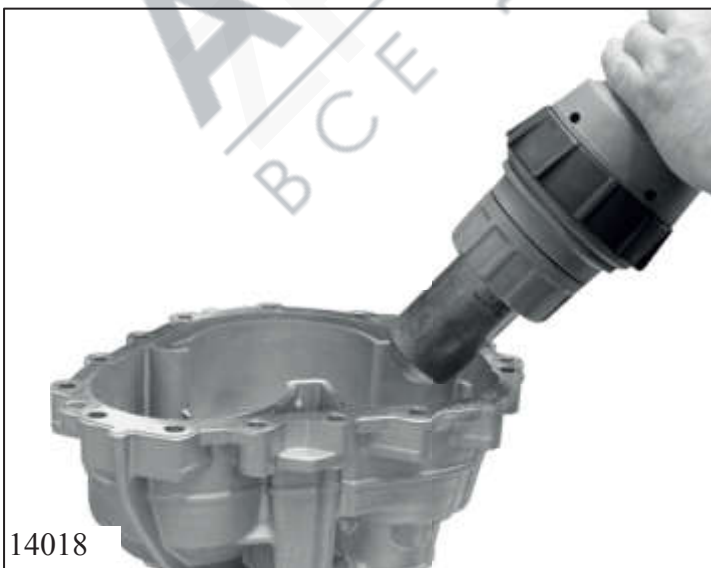

#### ⚠ CAUTION

#### Danger of burns

⇒ Wear safety gloves

Heat bearing seats with a hot air blower.

#### *New intermediate housing*

Press new bearing shells (37.120/130, 37.140/150) into intermediate housing (37.070/110) using tool AA00.600.587.

14018

Fit pump annulus into pump (37.100) and secure pump with 4 screws (37.200) in intermediate housing.

(See section 1.5 for tightening torques)

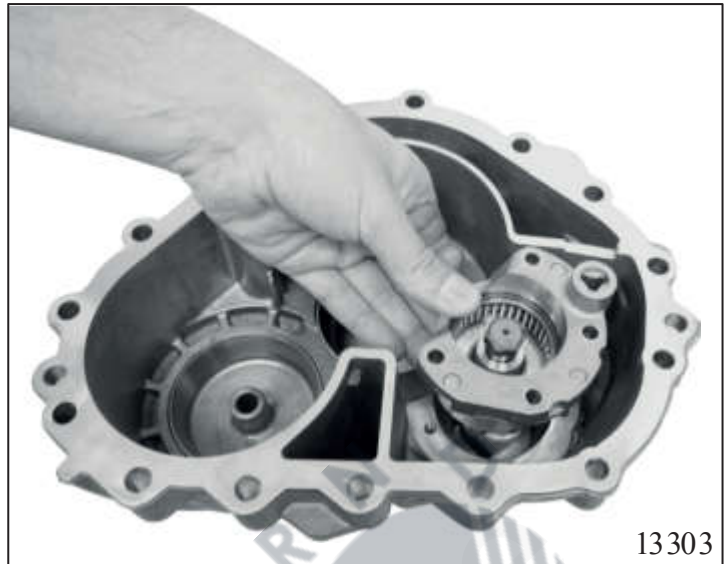

### 3.7.2 Prepare transmission housing, assemble side shaft

**NOTICE**

Refer to section 1.4.9. Adjustment work

Fit shim S5 (37.240).

Drive bearing shell (37.120/120) into transmission housing using tool AA00.625.669.

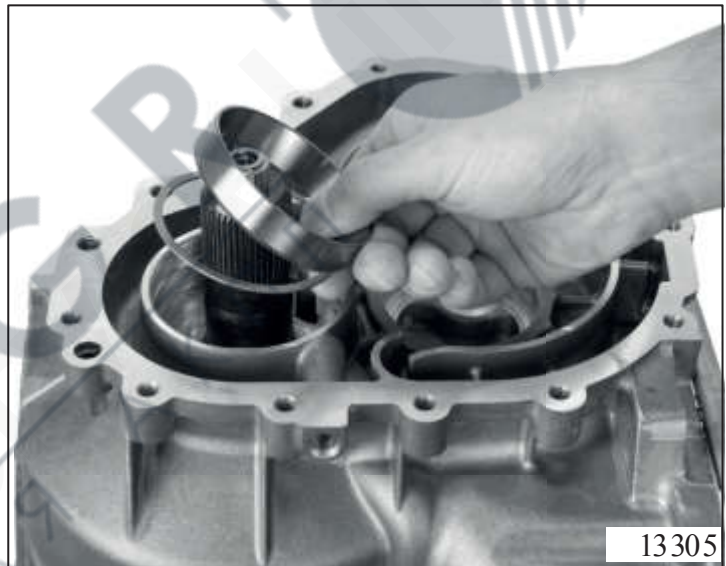

**NOTICE**

Refer to section 1.4.9. Adjustment work

Fit oil supply (37.030) into transmission housing.

Fit shim S4 (37.050) and drive in bearing shell (37.040/140) using tool 5x46.003.834.

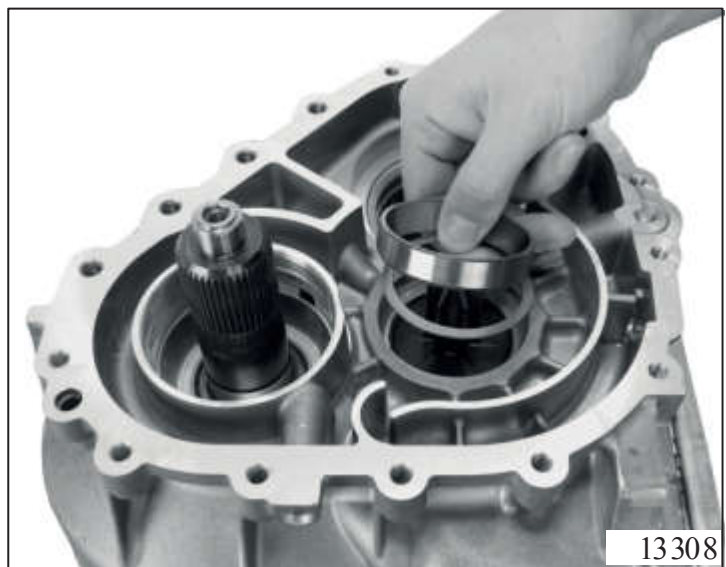





09064

Fit side shaft (37.010 (110) in press-on device 5x46.003.738.

Fit retaining plate (37.010/130).

Press on ball bearing (37.010/140) using tool 5x46.003.738 with mandrel press AA01.072.185.

Secure ball bearing with a snap ring (37.010/150).



09065

Place protective sleeve on connection shaft (37.010/160).

Press connection shaft on to side shaft using mandrel press.

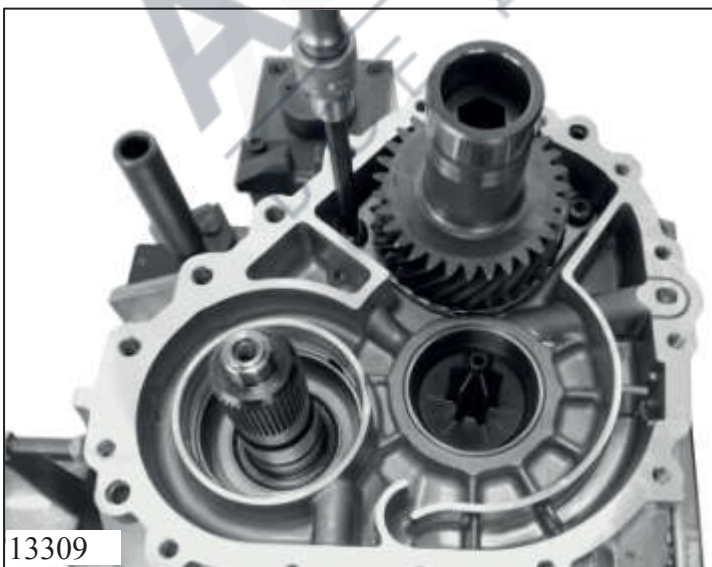

13309

Place side shaft in transmission housing and secure it with 2 screws (37.020).

(See section 1.5 for tightening torques)

### 3.7.3 Complete drive wheel

Position drive wheel (37.120/110) on tool 5x66.000.075.

Press large tapered roller bearing (37.120/130) on to drive wheel using tool AA00.622.346 with mandrel press AA01.072.185.

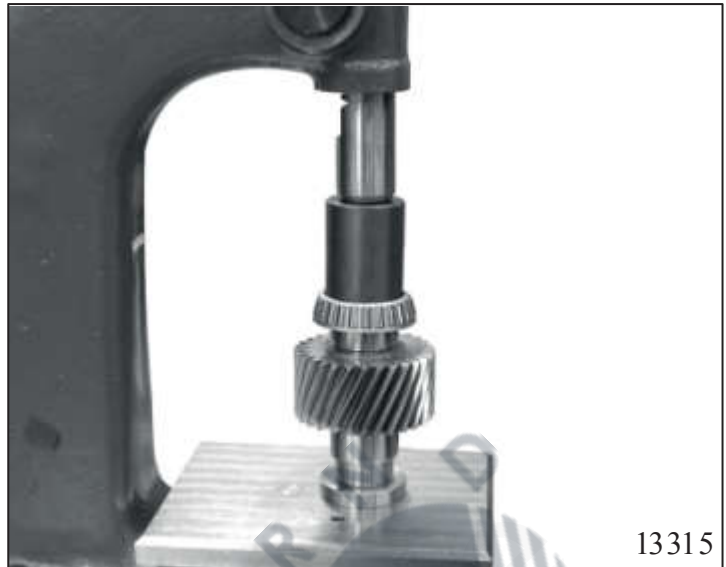

Turn drive wheel through 180°.

Place tool 5x46.004.033 on drive shaft.



Position shaft sealing ring (37.120/140) (with flat side facing upwards) over tool on drive wheel.



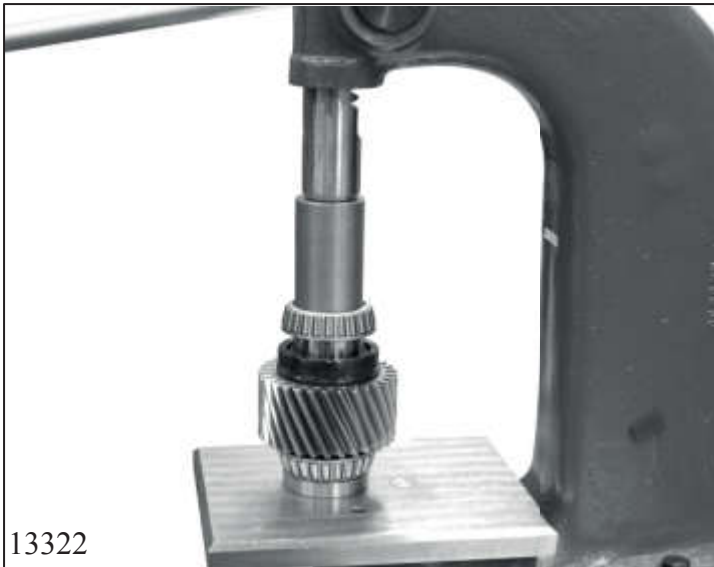

Remove tool.

Position drive wheel on tool  
5x66.000.075.

Press small tapered roller bearing  
(37.120/120) on to drive wheel using  
tool AA00.621.827 with mandrel press  
AA01.072.185.



Remove drive wheel from tool.

Turn drive wheel over.

Fit disk spring (37.250) in drive wheel  
borehole.

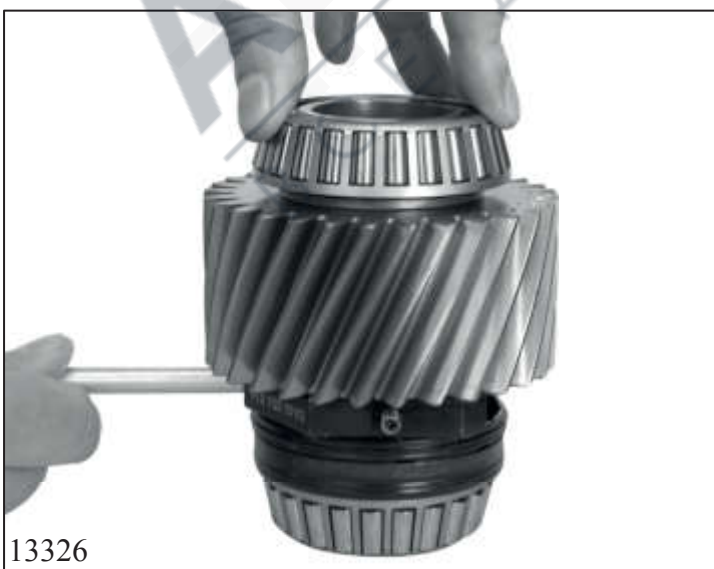

Position tool 5x46.004.034 between shaft  
sealing ring and drive wheel.

### 3.7.4 Complete output gear

Press tapered roller bearing (37.140/150) on to output gear (37.140/110) using 5x46.003.711 and mandrel press.



Press in small needle sleeve (37.140/120) into drive wheel using tool 5x46.003.711 and mandrel press.

Press in small needle sleeve (37.140/130) into drive wheel using tool 5x46.003.711 and mandrel press.

Secure it with a snap ring (37.140/140).



### 3.7.5 Complete front axle shaft

Press small tapered roller bearing (37.040/140) on to front axle shaft (37.040/110).using tool AA00.600.703 and mandrel press.

Press small needle sleeve (37.040/120) (with lettered side facing upwards) into mandrel of tool AA00.600.703 and press it into front axle shaft (small diameter) using mandrel press.





Connect needle bearing (37.040/130) to front axle shaft.

Fit output gear on to front axle shaft.

### 3.7.6 Assemble drive wheel, front axle shaft and output gear

#### **NOTICE**

Refer to section 1.4.9. Adjustment work

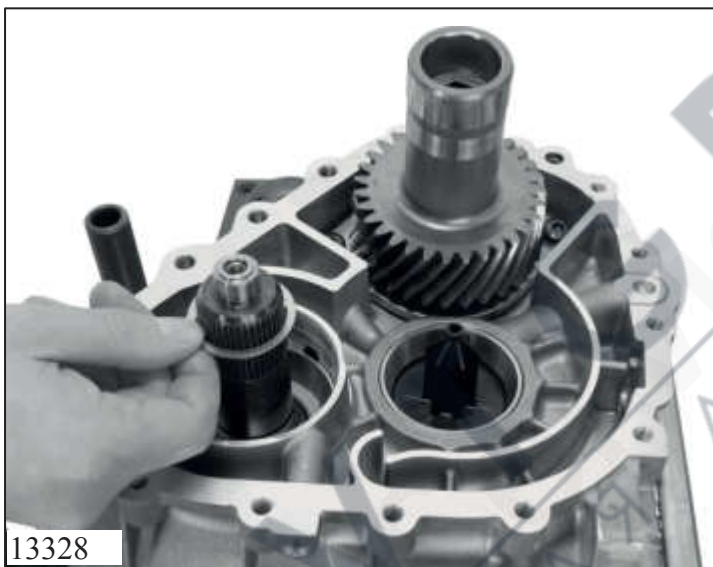

Fit shim S6 (37.220) over output shaft.

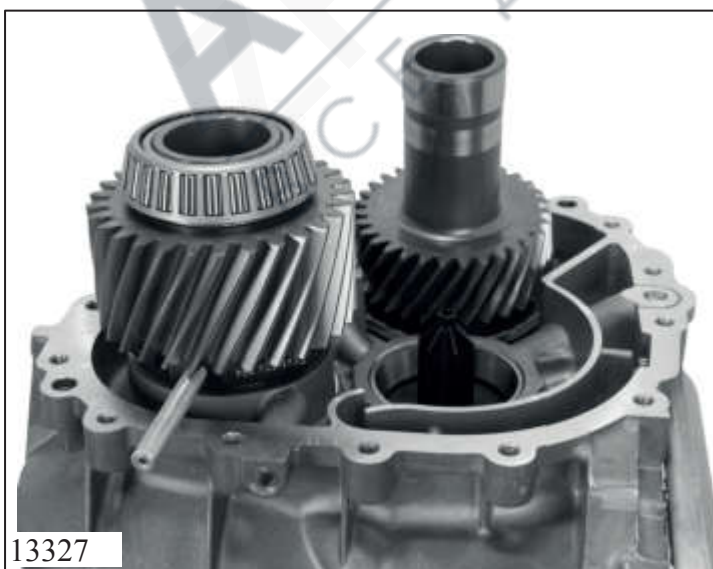

Press drive wheel into transmission housing using tool. Tool 3 times each rotate by  $90^\circ$  so that shaft seal is in position.

The tool must be on sealing surface of transmission housing.

Remove tool.

Block drive wheel by activating parking lock.

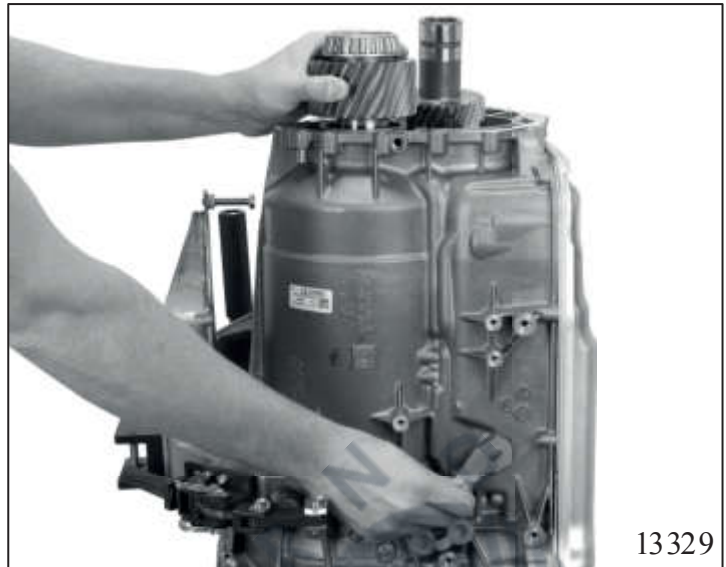

Secure drive wheel with screw (37.266).

(See section 1.5 for tightening torques)



Fit front axle shaft with output gear using auxiliary tool 5x46.003.843 in transmission housing.



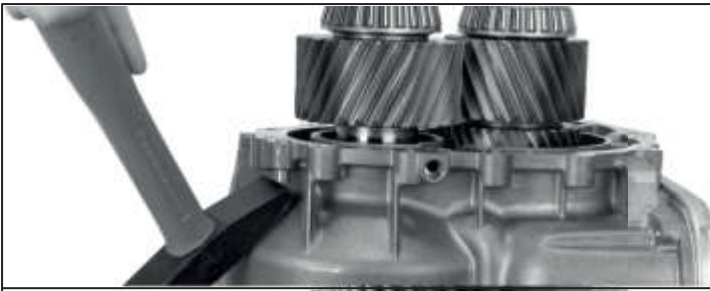

Drive 2 clamping sleeves (37.340) approx. 1 mm beyond sealing surface of transmission housing.



13348



1. Position new seal (37.280) on sealing surface.

2. Align hexagonal secondary pump in intermediate housing with side shaft hexagon.



13349

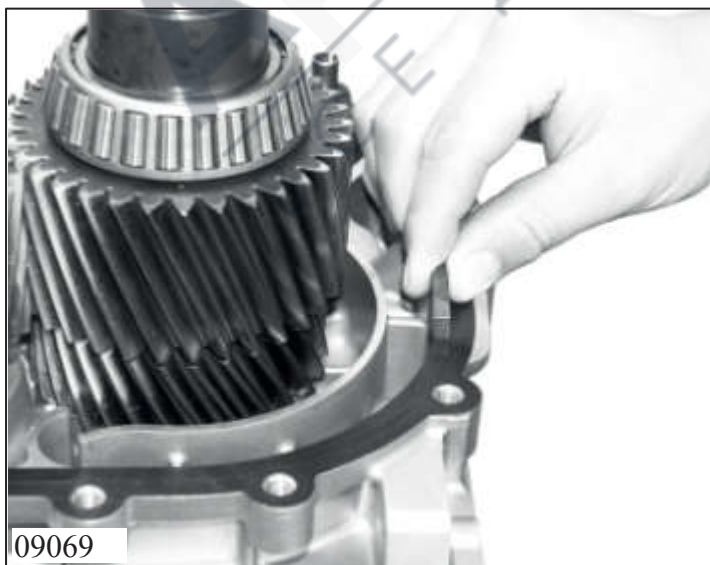

Fit magnet (37.270) in recess of transmission housing.

09069

Position intermediate housing and press it secured on to transmission housing.

Drive in adjusting pin flush with housing.

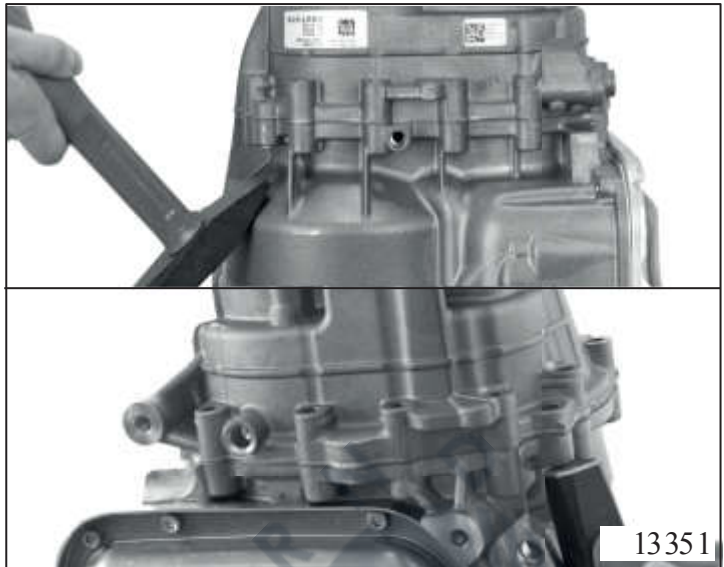

**NOTICE**

Section 1.3, see screw connection specification

Secure intermediate housing with 4 hexalobular screws (37.320) and 11 new aluminum torx screws (37.300).



Screw oil drain screw in rear axle output (37.070/130) into intermediate housing.

(See section 1.5 for tightening torques)





### 3.8 Assemble rear axle output

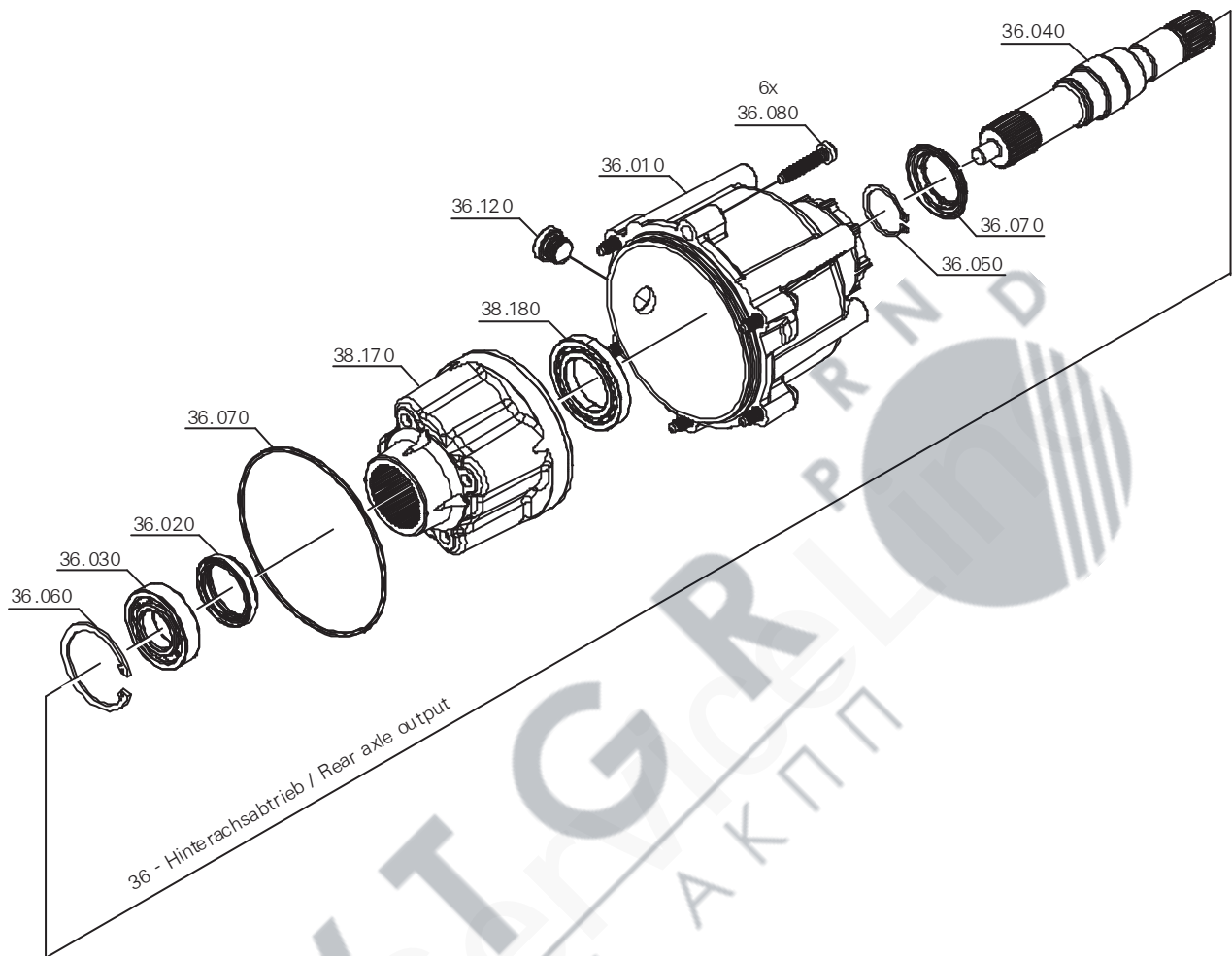

#### 3.8.1 Prepare and assemble distribution housing

Press ball bearing (36.030) into distribution housing (36.010) using tool and mandrel press.



13344

Secure ball bearing with a new snap ring (36.060).

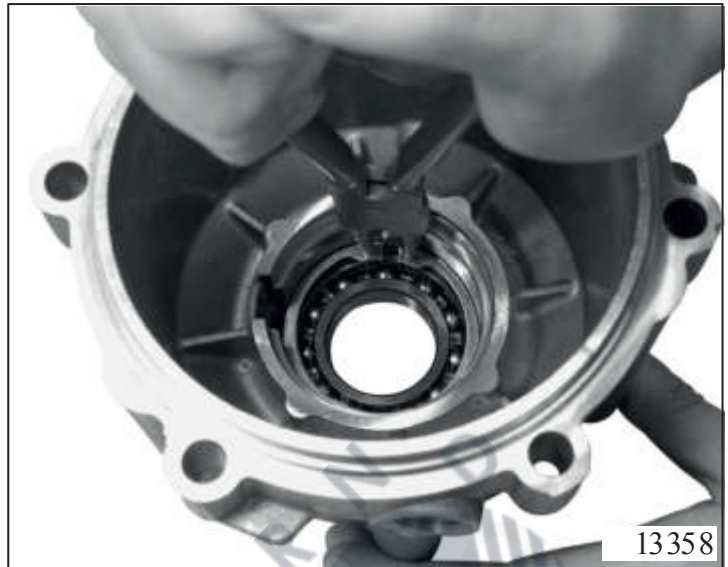

Insert a new shaft sealing ring (36.020) using tool AA00.578.569.

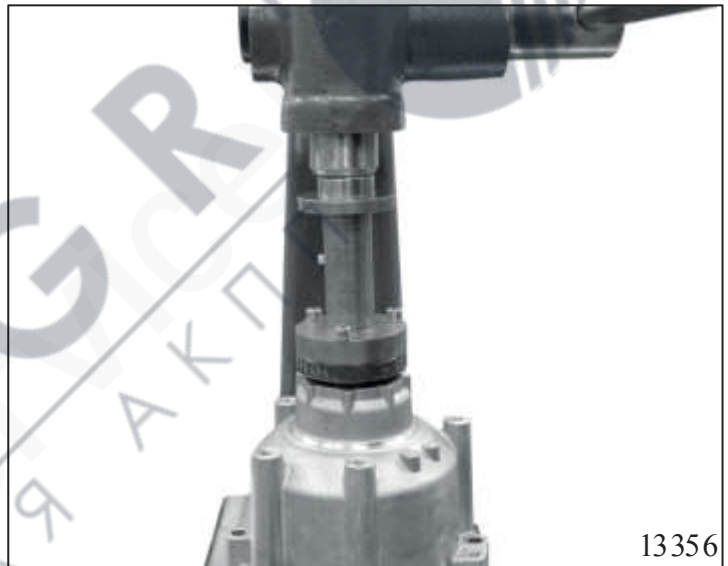

Press in plug-in shaft (36.040) with the vibration damper using mandrel press.



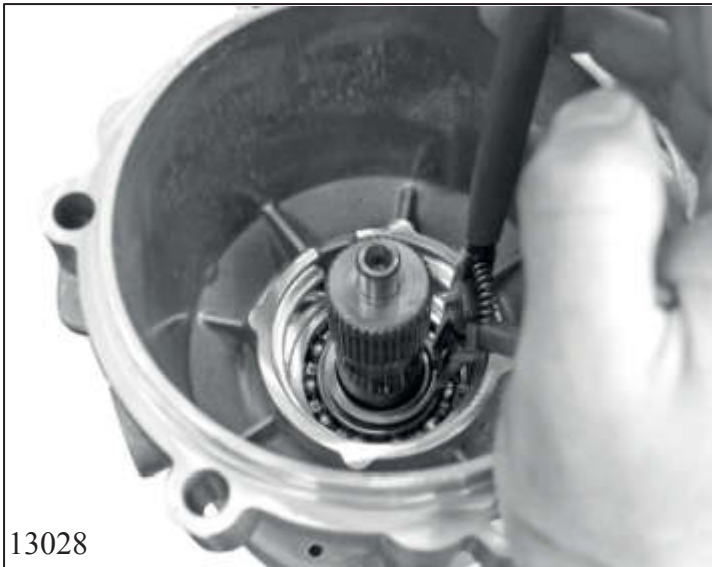

Secure plug-in shaft with a new snap ring (36.050).



Screw new rear axle output oil filler plug (36.120) into transmission housing.

Fit new O-ring (36.070) on distribution housing.

(See section 1.5 for tightening torques)



### 3.8.2 Complete and assemble the rear axle output

Fit differential (38.170) with ball bearing (38.180) in intermediate housing.

Position and align distributor cover on intermediate housing with oil filler plug is flush with side shaft.

(See section 1.5 for tightening torques)



**NOTICE**

Section 1.3, see screw connection specification

See section 1.5 for tightening torques.

Secure distributor cover and intermediate housing with 6 new aluminum screws (36.080).

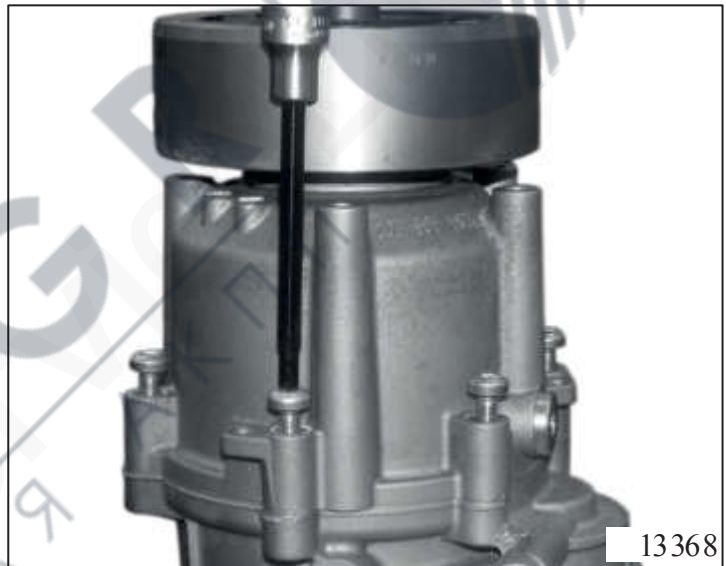

*Transmission without vibration damper*

Guide spray ring (36.070) over plug-in shaft and clip it in.



*Transmission with bending vibration damper*

1. Guide spray ring (36.070) over plug-in shaft and clip it in.
2. Place vibration damper (36.090) on distribution housing.
3. Secure vibration damper with 3 new coated screws (36.100).

(See section 1.5 for tightening torques)

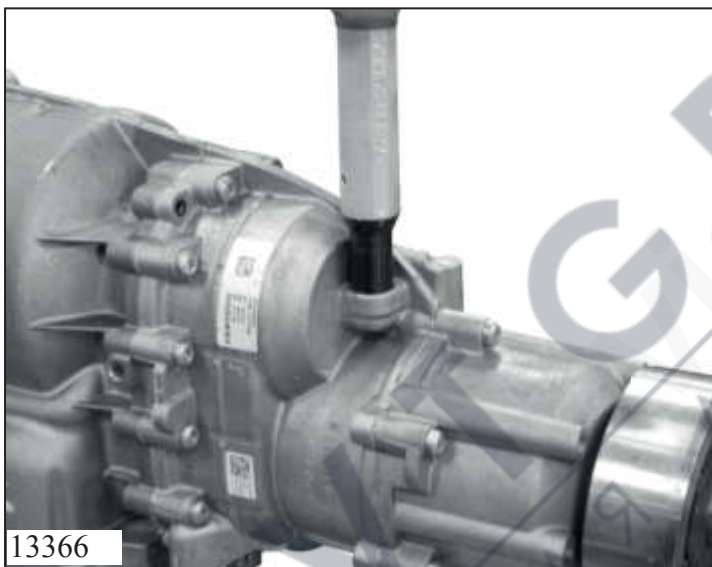
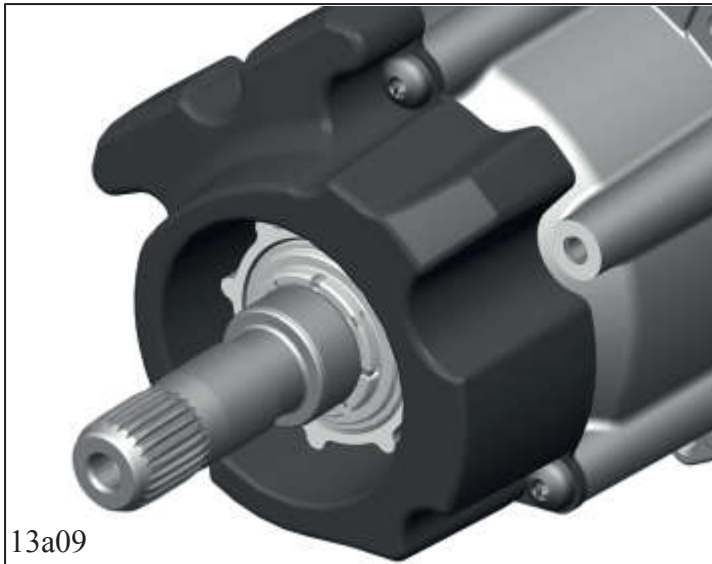

Drive vent tube (38.400) into intermediate housing using tool 5x46.003.018.

Press vent cover (38.410) into vent tube.



<b>Revisions</b>			
Rev A	Date of document creation		2014/04/04
Rev B	Corrections in Chapter Adjustment work Phrase reunification für english translation		2014/06/05
Rev C	Update screw connection specification differential cover, converter housing and guide plate	1.3/1 - 1.3/2	2014/11/21
	Update tightening torque nut pinion shaft	1.5/1	
	Various changes in the document	1.4/25, 1.4/28, 1.4/30, 2.2/1, 2.2/7, 2.3/4, 2.3/6, 2.3/9, 2.5/3, 3.1/1, 3.1/2, 3.1/3, 3.1/5, 3.4/2, 3.5/3, 3.6/3, 3.6/9, Kap. 3.7	

AVTIGRILL  
 ВСЕ ДА Я А К П П







**ZF Friedrichshafen AG**

ZF Services

Metzer Str. 160

66117 Saarbrücken

Deutschland/Germany

Telefon: +49 681 920 0

www.zf.com

Order-No. 1087 751 103

Version 14/1 1/21 - C

Presented by:

